

月光椿

Moonlight  
Camellia  
Final



**ADULT  
ONLY**

Thank you so much for picking up Doku Doku Vol.14 "Moonlight Camellia Final"

Warning, this book contains the following:

- Sexual themes intended for adults
- Blood, guts, and destruction of human bodies



This story is a works of fiction.  
There are no connections to real-life people, organizations, or places.



# ■せんでん■

オンラインで毎月絶賛連載中

現在コミックムーンで毎月  
オンライン連載中の氏賀Y太による  
エログロ漫画「Dr. 乳児郎の憂鬱」  
赤ちゃんマスクを  
被った乳児郎博士が  
拉致した女の子に体液  
と血液にまみれた絶望  
的なゲームを提案する

配信ポータルページは  
下のQRコードで  
アクセス！



## Dr. 乳児郎の憂鬱

氏賀Y太

### 第一章「絶頂ゲーム」



### 第二章「血涙ゲーム」

第三章近日配信予定！

# SUMMARY OF THE FIRST BOOK

One day, an introvert named Tsubaki Katagiri stops coming to school. Rumours of her being kidnapped or having ran away from home spread across her class. A classmate of hers, Rento Haieda, has no interest for other people, and doesn't really care for Tsubaki's disappearance either. However, that night, Tsubaki appears behind Rento's window wearing next to nothing, and makes a request with tears in her eyes: "Please let me into your room". It turns out the girl has transformed into a vampire, and wants Rento to let her suck his blood.



This marks the beginning of Rento's strange nocturnal life with the now-vampire Tsubaki. Rento offers to give her his blood, but over time undergoes some changes. He gains superhuman strength and becomes extremely violent, putting Tsubaki's immortality to good use as he becomes completely absorbed in torturing her. Tsubaki might be an introvert, but that alone doesn't explain why she still decides to stay with Rento. There is one more reason.

She has secretly had a crush on him from the start.

Rento likes to take Tsubaki to go shopping with him every once in a while. However, one night on their way back home, they come across a girl from their class...



This book continues from here

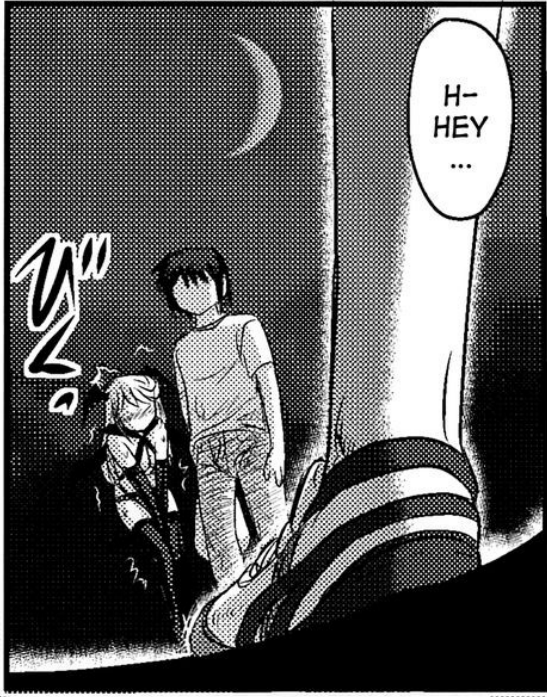

H-HEY ...



!



TAKA-CHIHO ...!?

YOU'RE THAT MISSING GIRL... KATA-GIRI... RIGHT?

REN-TO... AND...

Ah...! Aah...



DOING TO-GETH-ER...?

WHAT ARE YOU TWO ...



YOU  
TWO DON'T  
EVEN COME  
TO SCHOOL  
ANYMORE  
...

WHAT  
ARE  
YOU  
DOING?



AND ON  
TOP OF  
THAT,  
KATAGIRI...  
DID YOU  
JUST  
TRANSFORM  
FROM SOME  
KIND OF A  
WEIRD  
ANIMAL?

W-w-w-  
what  
should  
I do...?

SHIT...  
OF ALL  
PEOPLE, IT  
HAD TO BE  
SOMEONE  
FROM OUR  
CLASS...

# 月光椿

GAKKOU TSUBAKI  
FINAL



**Shy vampire girl TSUBAKI under the moonlight**



WELL ...

UUM ...

I CAN'T BELIEVE IT... YOU'RE USING HER AS YOU PLEASE?

RENTO... DID YOU KIDNAP HER?

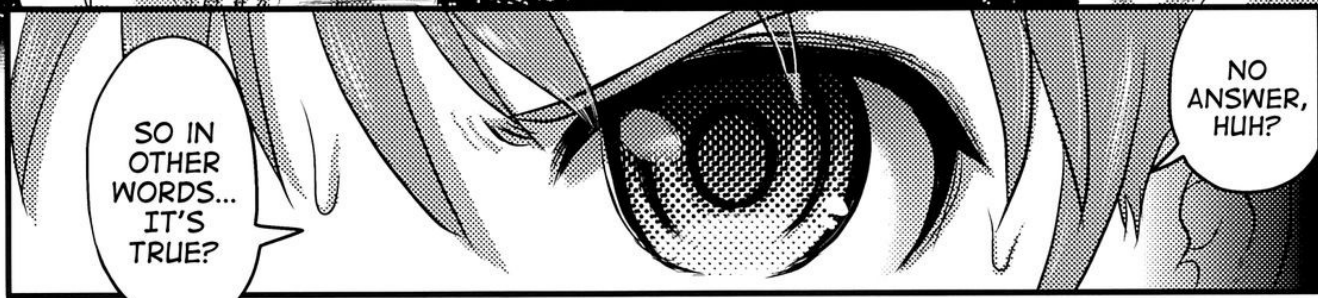

SO IN OTHER WORDS... IT'S TRUE?

NO ANSWER, HUH?



I-I MEAN... IF YOU REALLY HAVEN'T DONE ANYTHING WRONG, THEN...

NOW, SHALL WE GO SEE THE POLICE?

AL-RIGHT THEN.

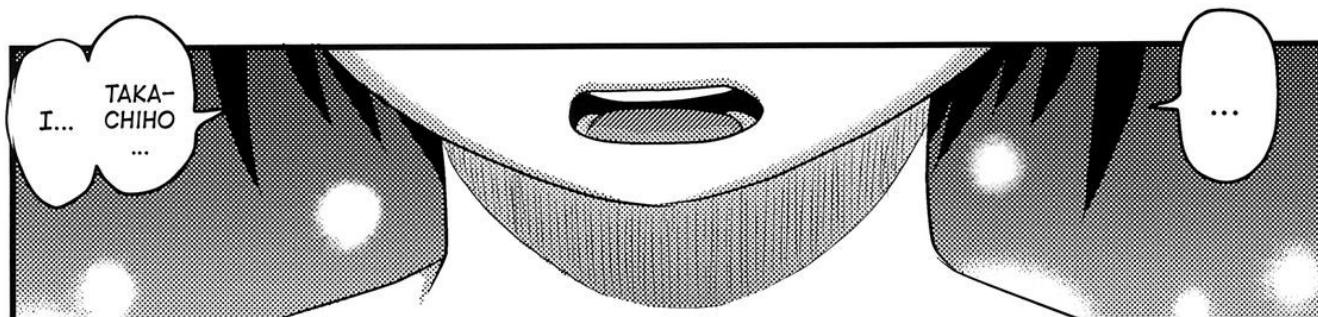

I... TAKA-CHIHO ...

...









THIS IS IT!

THIS IS IT!

THIS IS IT!  
THIS IS IT!

THIS IS THE THING THAT CAN SATISFY MY THIRST!



TAKA-CHIHO JUST DIED...

CAN ONLY  
EAT  
HUMAN  
BODIES  
...

GHOULLS  
...

GHOULLS  
...?

WAIT  
...

I SEE,  
I SEE~  
SO,  
THAT'S  
WHY...

HUH?



AND NOT EVEN WHEN I...

NO WONDER I NEVER FELT GUILTY WHILE TORTURING YOU...

HAHA! NOW IT ALL MAKES SENSE!

KILLED MY OWN CLASSMATE!

SO THAT'S HOW IT IS ...



HAHA... HEHE!

SO, I REALLY AM A MONSTER NOW, HUH?

AND WHY I WANTED TO EAT HUMAN FLESH SO BAD.

I DID WONDER WHY I GOT SO STRONG.



HEY, TSUBAKI! DON'T JUST SIT THERE, GIVE ME SOME ANSWERS!

CUM!



HUH...? WELL... THAT'S WHAT SHOULD HAVE HAPPENED ...

"SHOULD HAVE"? WHAT DO YOU MEAN "SHOULD HAVE"!?



SINCE YOU DRANK MY BLOOD ...

I'M GOING TO TURN INTO A VAMPIRE, RIGHT?

LOST MY QUALIFICATION TO BECOMING A VAMPIRE?

SO, YOU'RE SAYING THAT BECAUSE I RAPED YOU BEFORE YOU SUCKED MY BLOOD...  
I WAS NO LONGER A VIRGIN, AND...

HUH? AND NOT ONLY THAT, BUT...

I WAS TURNED INTO A GHOUL?  
SINCE I DRANK YOUR VAMPIRE BLOOD...

BASICALLY ALL MY FAULT...  
IT'S ...

THAT MEANS ...  
Well... I did drink it...  
SO ...



THERE IS...?

HM?

REGAIN YOUR HUMANITY...

THERE IS A WAY FOR YOU TO...

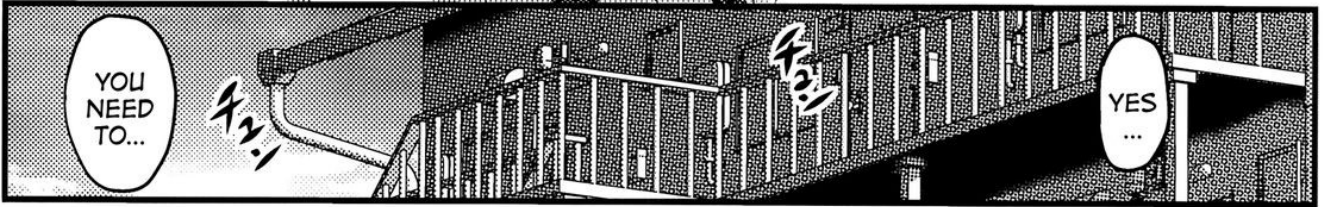

YOU NEED TO...

YES ...



SURE ...



HEY... TSUBAKI...

GIVE ME SOME TIME TO THINK ABOUT IT...



I... SEE...

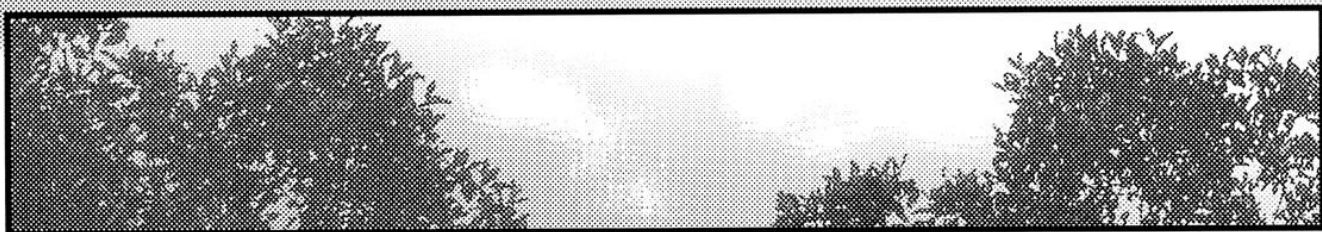
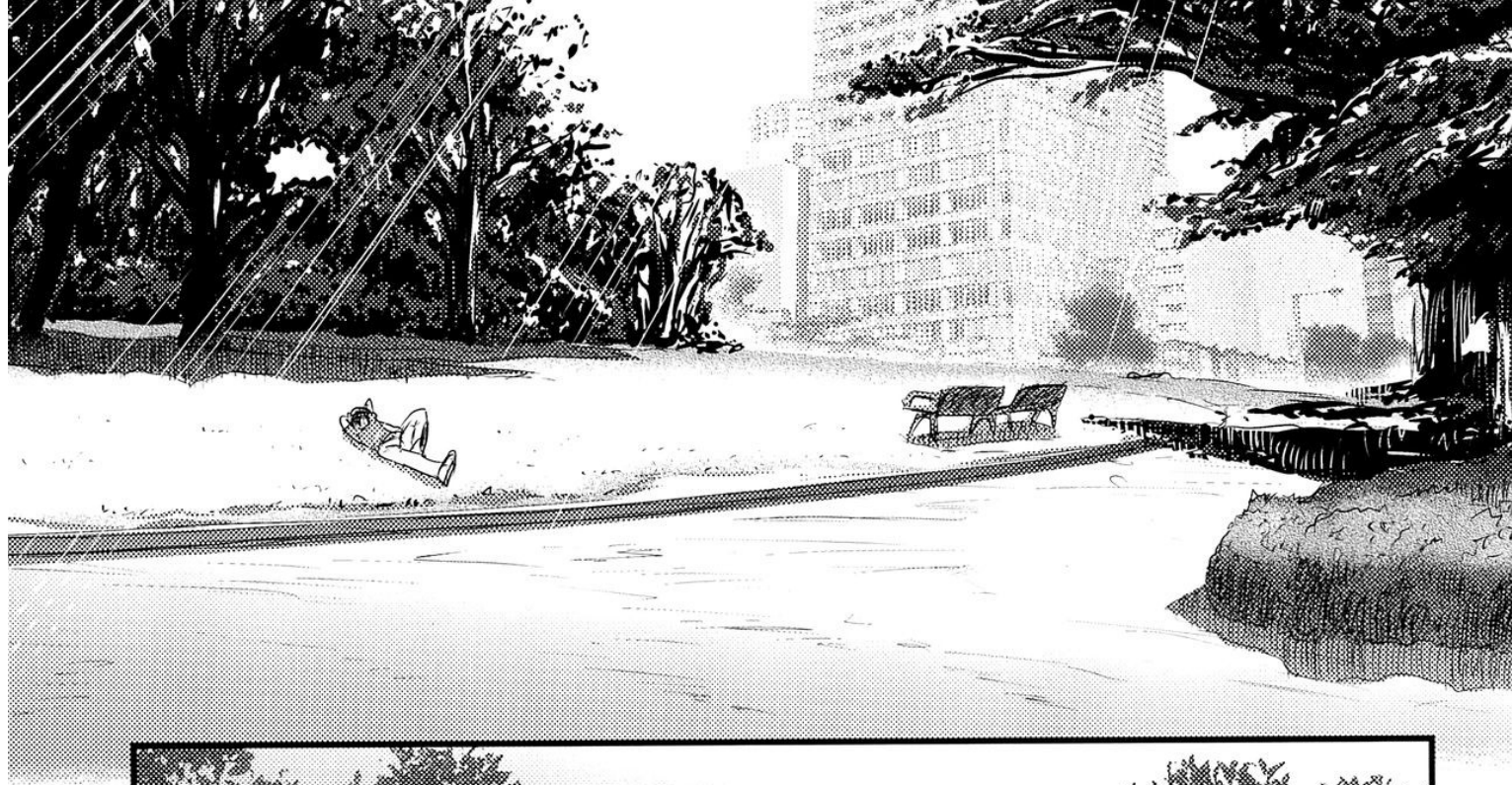

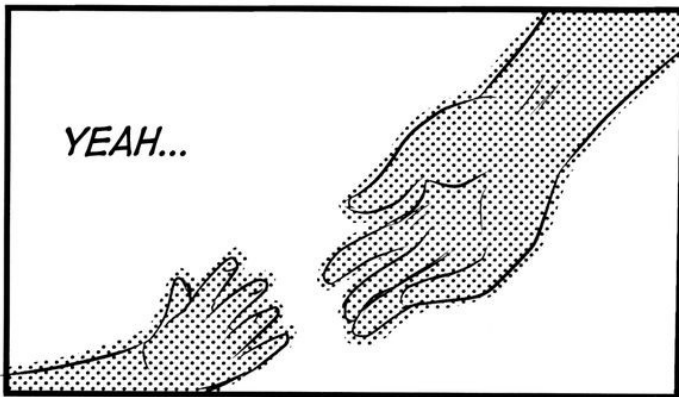

AND ORDINARY...

AND BORING...

PEACEFUL...

I FINALLY UNDER-  
STAND  
NOW THAT  
I'M A  
MONSTER.

BEING A  
HUMAN  
ISN'T  
REALLY  
ALL THAT  
BAD.





WHY DID SHE HAVE TO GET ME INVOLVED?

SUCKS FOR HER THAT SHE WAS TURNED INTO A VAMPIRE, BUT...

ええ

ええ



TO REGAIN YOUR HUMANITY, LORD RENTO, YOU...

NEED TO USE YOUR HAND TO...



WAS SHE REALLY JUST LONELY KNOWING THAT SHE WOULD NEVER SEE THE SUN AGAIN, AND...

WHAT A SELFISH FUCKER.

WANTED TO HAVE SOME COMPANY...?

LONELY, HUH...?

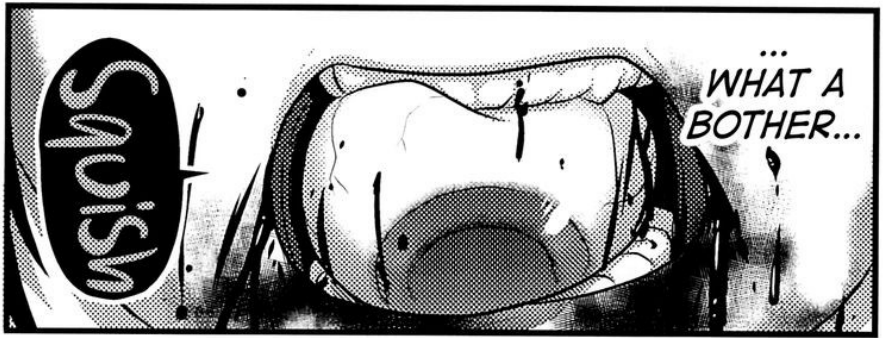

Squish

... WHAT A BOTHER...

I MIGHT  
BE EVEN  
MORE  
SELFISH  
THAN HER...

ALTHOUGH,  
I THINK  
THAT...

TOO  
SCARED  
TO HEAR  
MY  
ANSWER,  
AND RUN  
AWAY.

I WAS  
SURE  
YOU'D  
BE...

...

WERE  
YOU  
WAITING  
FOR  
ME?

HUH  
...?

YES.

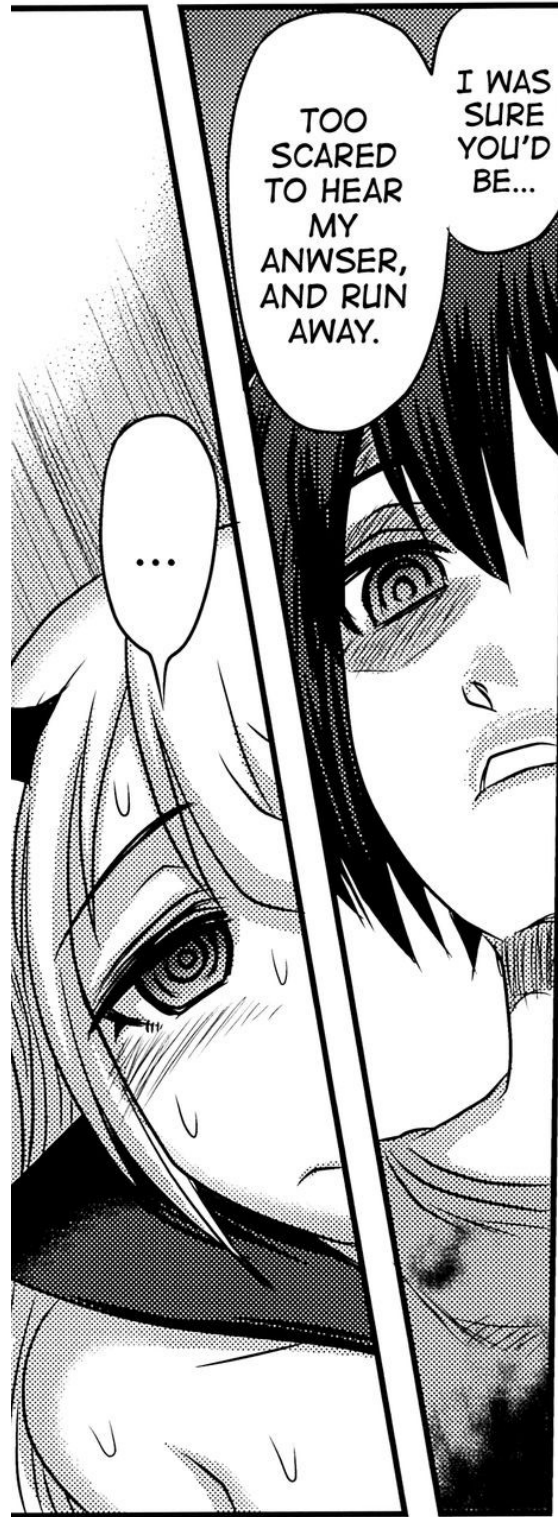



PLEASE  
DRIVE  
A STAKE  
THROUGH  
MY  
HEART  
...

GO  
AHEAD  
...



AL-  
RIGHT  
...

STOP COVERING YOUR BODY WITH YOUR HANDS! IT'S TOO LATE FOR THAT!

SURE, THAT'S FINE. BUT...

ANY LAST WORDS, TSUBAKI?

HUH? YOU'RE STILL EMBARRASSED? REALLY?

YOU KNOW YOU'RE ABOUT TO DIE, RIGHT? WEIRDO.

I...

UHM... UHM...

NO : :





LET'S BEGIN.

TSU-BAKI...

Creak

Twist



GETTING TOYED WITH BY SOMEONE LIKE ME, AND THEN BEING KILLED AT THE END.

ARE YOU SAD?

IT'S A PRETTY EMPTY LIFE, HUH?



I WAS ACTING SELFISH ...

I APOLOGIZE ...

... NO.



I'LL  
MAKE  
OUR  
LAST  
TIME A  
GOOD  
ONE!

OH?  
WELL  
THEN  
...

IDD

CH!



THIS ONE TOO!



THAT'S WHY I GET SO FIRED UP WHEN I...

RIP YOU APART, OR EAT HUMAN FLESH, RIGHT!?



HEY, TSUBAKI.

THIS KIND OF BRUTALITY IS NATURAL FOR GHOULS, RIGHT?



CRUEL  
!!!

ゴゴゴゴ  
ゴゴゴゴ



YEAH  
...

HUMANS  
CAN BE  
PRETTY  
...

Clench



Y-YES...  
CORRECT  
...

BUT  
...



ABOUT  
HALF  
OF IT...

WAS  
ALWAYS...  
IN YOU...  
IT'S THE...  
HUMAN  
NATURE...

DON'T GO DYING BEFORE I STAB YOU WITH THE STAKE, OKAY!?

TSU-BAKI!

HAHA!

I'LL GRAB YOUR WOMB!

I CAN'T DIE...

I... I WON'T DIE...

YOU HEAR ME!?

AFTER ALL... VAMPIRES ARE JUST ...

I SEE ...

Crum

PRE-TENDING TO BE ALIVE ...



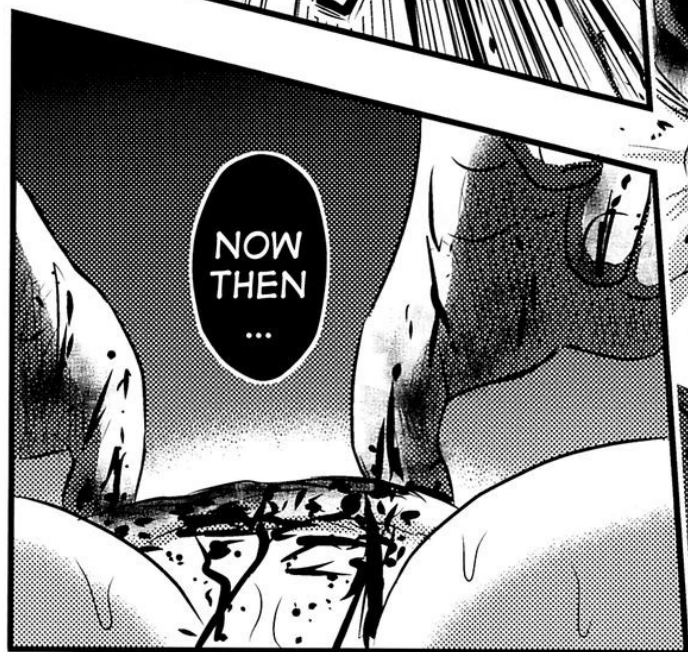

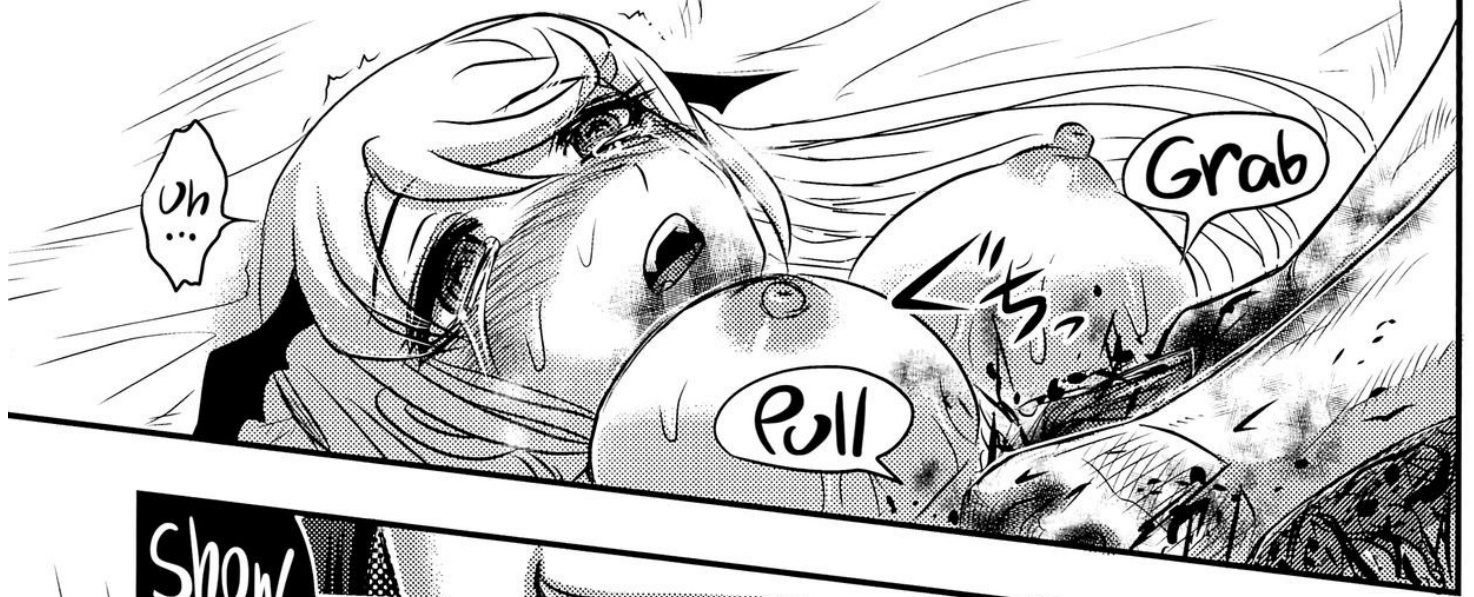

Show  
me it!

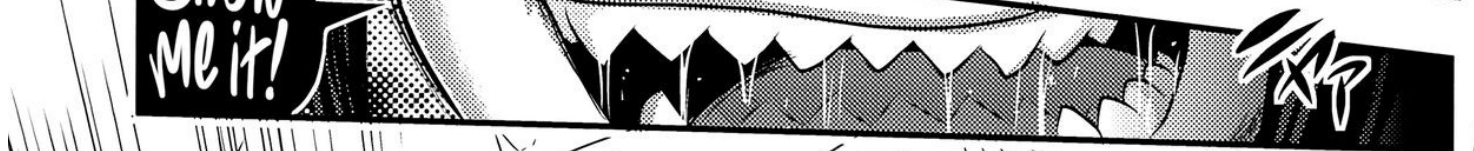

HEART  
!!!

YOUR  
...



LOOK!  
IT'S IN!



IT'S SO GOOD, TSU-BAKI!

IT'S LIKE A LUMP OF MUSCLE!

YOUR HEART IS SO FREAKING TIGHT!



TRY TO STRUGGLE!

GO AHEAD, TSUBAKI!

FIGHT BACK!



UH...



Slow

Slow

Ah



I'M CUM-MING!

CUM-MING ...!





カッ

カッ

カッ...

カッ

カッ



I WAS KINDA THINKING YOU'D JUST INSTANTLY DISAPPEAR AS SMOKE ...

MORE OF THIS, HUH ...?



IF YOU HAD RELIED ON SOME OTHER GUY...

THEY'D PROBABLY HAVE BEEN A BIT GENTLER TO YOU.



HUMANS  
ARE  
GOOD?  
WHAT A  
JOKE.



I'LL  
GO BACK  
TO MY  
SHITTY,  
BORING  
LIFE...

THE  
ONLY  
PERSON  
I'VE EVER  
CARED  
THIS MUCH  
ABOUT  
...



WAS  
YOU  
...



THE HELL ARE YOU DOING?

HEY, YOU ...



KA-ZURA.

I'M THE VAMPIRE WHO SUCKED TSUBAKI'S BLOOD...

WHO DO YOU THINK YOU'RE CALLING A KID? I'VE LIVED FOR 254 YEARS.



AN-OTHER VAMPIRE ...?

A-

And it's a kid...





YOU SURE ARE ACTING AWFULLY SUPERIOR TO YOUR MASTER, TSUBAKI.

I was her servant...?

FOR A LOWLY GHOUL WHO EXISTS SOLELY TO SERVE VAMPIRES ...



SO ...



H-HOW DO YOU KNOW THAT ...?

HEY ...



LET'S BE HONEST, WE BOTH KNOW THAT'S A LIE.

YOU CAN PRETEND LIKE YOU WERE TRYING TO KILL HER, BUT...

↑She could enter Rento's room uninvited since he isn't a human anymore.

IT'S NOT EXACTLY ROCKET SCIENCE, KIDDO!  
IT WAS YOUR FILTHY FUCKING COCK!

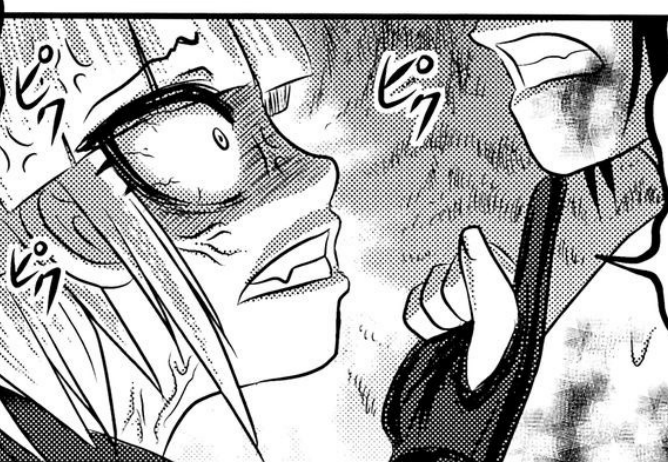

IT WASN'T A STAKE YOU STABBED HER WITH, WAS IT NOW...?



HEY!



WHY DO YOU INSIST SO RELENTLESSLY TO KEEP TOYING WITH TSUBAKI?

YOU HAD A CHANCE TO REGAIN YOUR HUMANITY!

ANSWER ME!



だっ! っ!

G



STILL HOLD A GRUDGE AGAINST HER, DON'T YOU?

IN THE END YOU ...



I CAN GUESS THE GIST OF IT EVEN IF YOU REMAIN SILENT.

HMPH ...

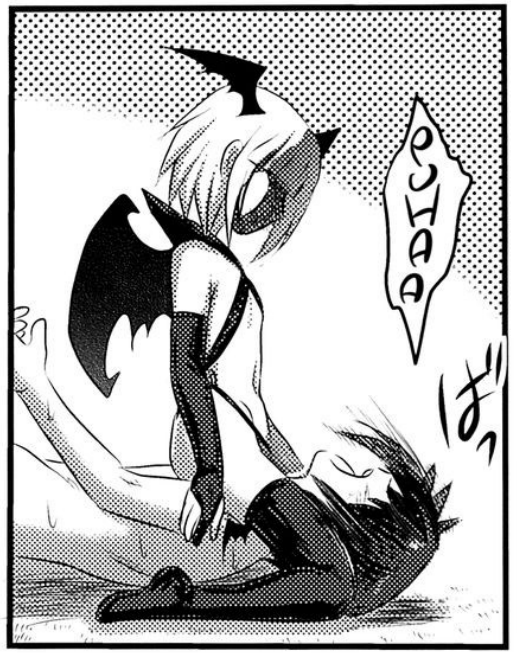

OH!



YOU INTEND TO TORTURE HER UNTIL YOU ARE SATISFIED, DON'T YOU!?

SPARE ME YOUR LIES!

N-NO...! THAT'S NOT...!



YOU VILE GHOUL!

AS A PROUD VAMPIRE, I'LL SLAY YOU!

PREPARE YOURSELF!



I DON'T INTEND TO EXPLAIN ANYTHING.

IF YOU'RE GOING TO KILL ME, THEN JUST DO IT.

TSK... YOU REALLY ARE A KID, HUH?

WHAT!?

YOU WOULDN'T GET IT.

!!  
!!

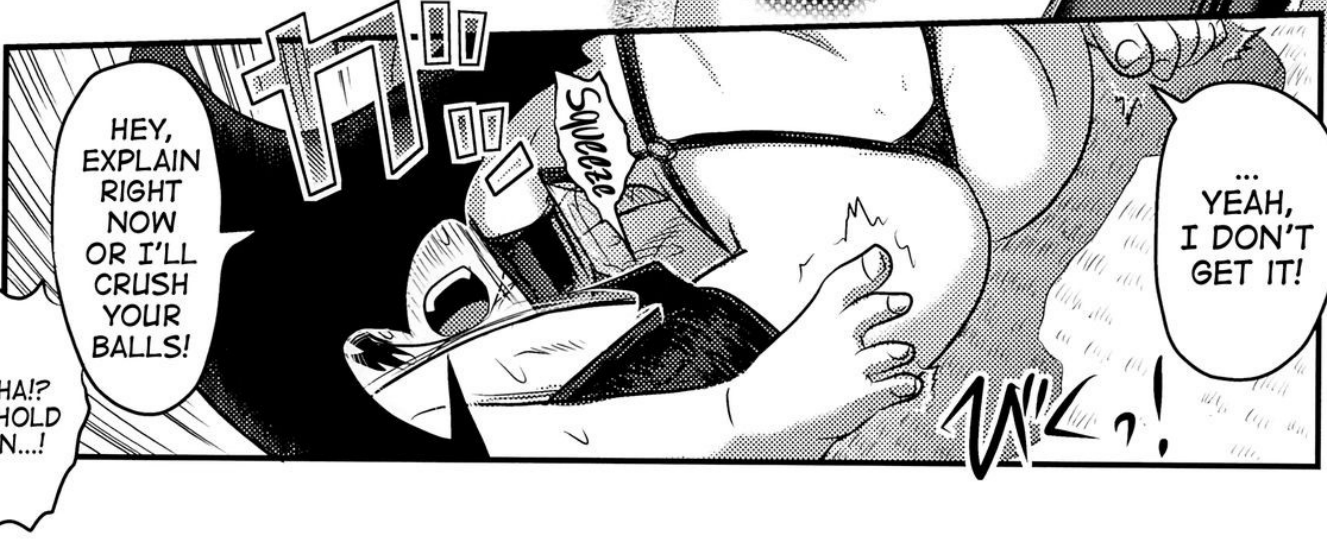

HEY, EXPLAIN RIGHT NOW OR I'LL CRUSH YOUR BALLS!

... YEAH, I DON'T GET IT!

WHA!? H-HOLD ON...!

!!  
!!



HEY  
...

TSU-BAKI  
...

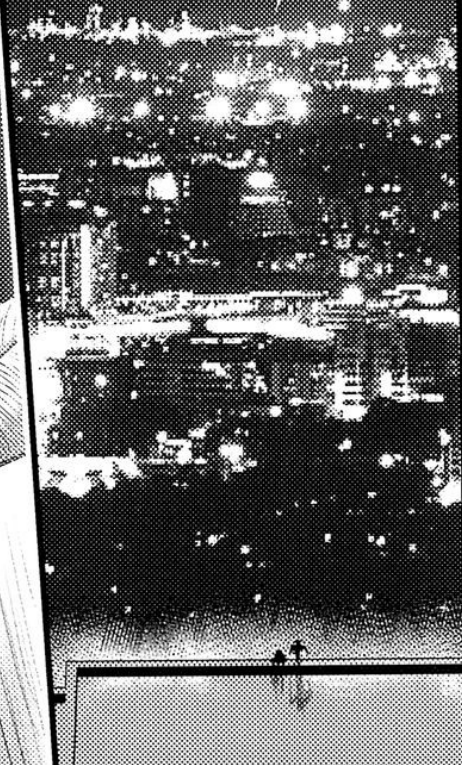

SHE HASN'T TOLD YOU ANYTHING, RIGHT...?

THAT VAM-PIRE, KAZURA  
...

Munch





NO  
...

NO-  
THING  
...



...

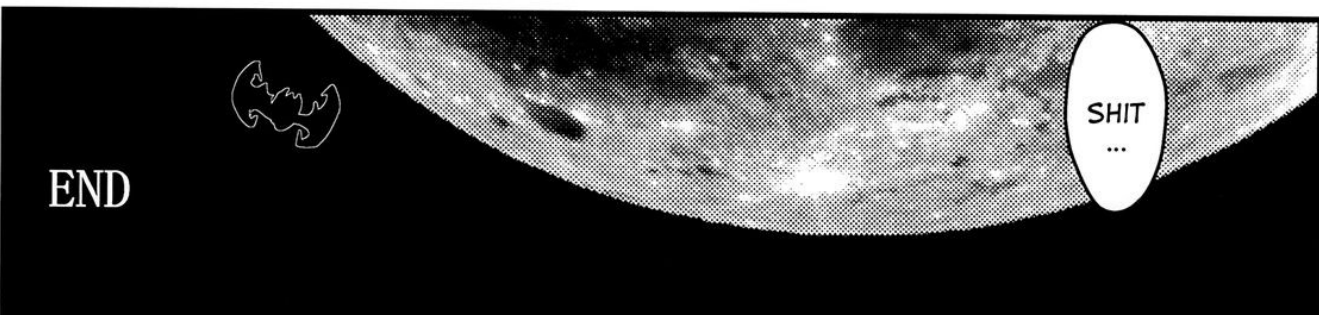

SHIT  
...

END

# Afterword

Thank you so much for reading through the Moonlight Camellia Duology. Vampires are of course completely fictional, and as such, there are multiple interpretations of their behaviour and weaknesses. In Moonlight Camellia, I made Tsubaki have most of the weaknesses I've read about in other vampire stories. I left out couple though, like silver, holy water, and crosses.

Basically, when a person has their blood sucked they turn into a vampire if they are a virgin, and into a ghoul if they are not. Ghouls experience insatiable desire to consume human flesh, and are able to transform into hyenas, although I didn't get a chance to portray that in the story.

I wanted this story to be about a person slowly turning into a ghoul, and while being driven by their desire to eat human flesh, lose their sense of morality. However, I chose not to dwell on that too much lest the book ended up overly verbose, and kept the exposition levels low. It would have been bad for the tempo.

The vampire who turned Tsubaki into one, Kazura, got her name from Tsubaki-Kazura (eng. Lapageria), which also happens to be the national flower of Chile. It's a flower in the lily family, so I bet there was some hot yuri action going on when Kazura turned Tsubaki into a vampire (she didn't take her virginity though).

I kinda wish I had made Rento jump out and shout "You're the one who turned Tsubaki into a vampire!" when Kazura appeared.

Right, I have been drawing manga for 20-odd years now, but I'm pretty sure this was my first time drawing one of these so called "Loli Babas". I really enjoyed this story as well, so I'm thinking I might draw more of it, if I ever get the chance.

I usually don't talk too much about my manga, but I finished my collection book, "Chishi Goyomi", just a bit earlier, and had some leftover enthusiasm from that. Now then, let us meet again!

2017.8  
G  
Q  
K



Lapageria

Discarded design for a double sided acrylic keychain

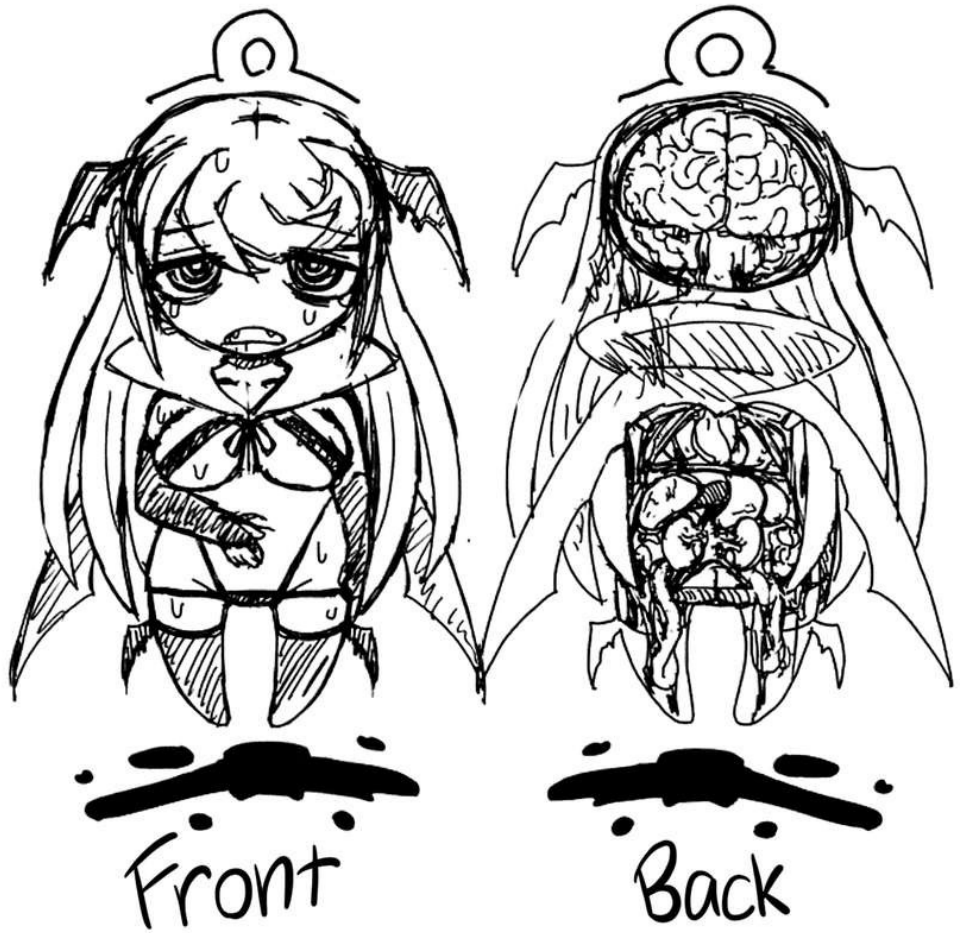



AS  
THE  
NIGHT  
FALLS  
...

EVERY  
ONCE  
IN A  
WHILE  
...

ハァ ハァ

# BELLY PUNCH!

Momoiro Manjiru (桃色卍流)



SHE  
COMES  
TO  
VISIT  
ME.

ハァ!



DID YOU KNOW?

IT'S GOTTEN THAT BIG ALREADY, HUH?

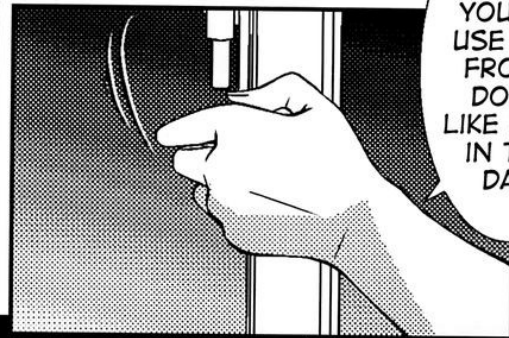

I TOLD YOU TO USE THE FRONT DOOR LIKE BACK IN THE DAY.

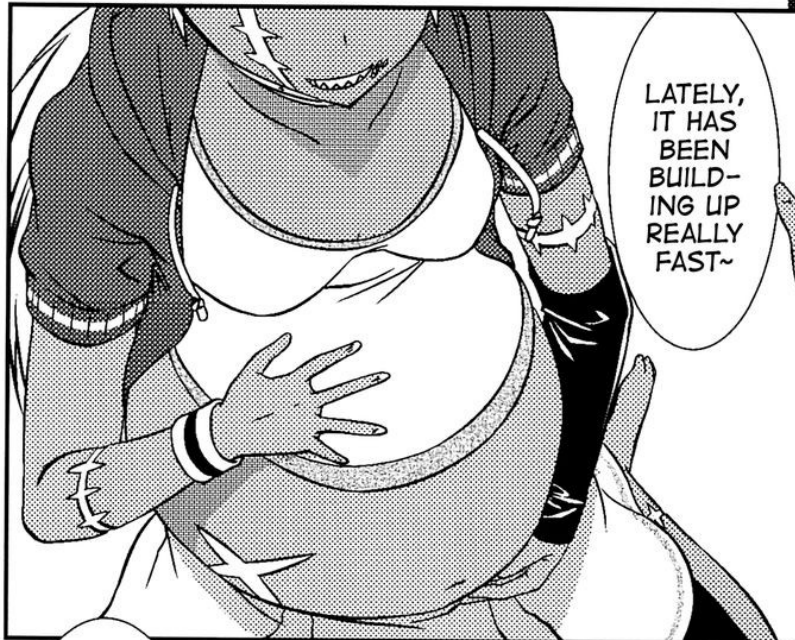

LATELY, IT HAS BEEN BUILDING UP REALLY FAST~



You're the one who made my belly like this, so...

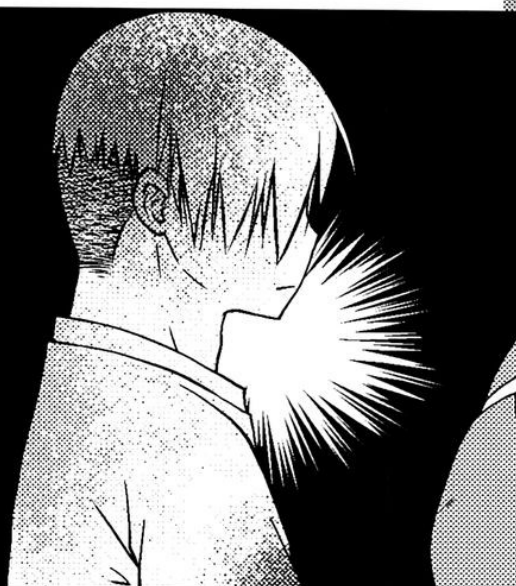

THIS WAY I GET TO MEET YOU QUICKER, TAKKUN!  
♥

Take responsibility, 'kay?

AL-RIGHT THEN.

NOW, STAY STILL.

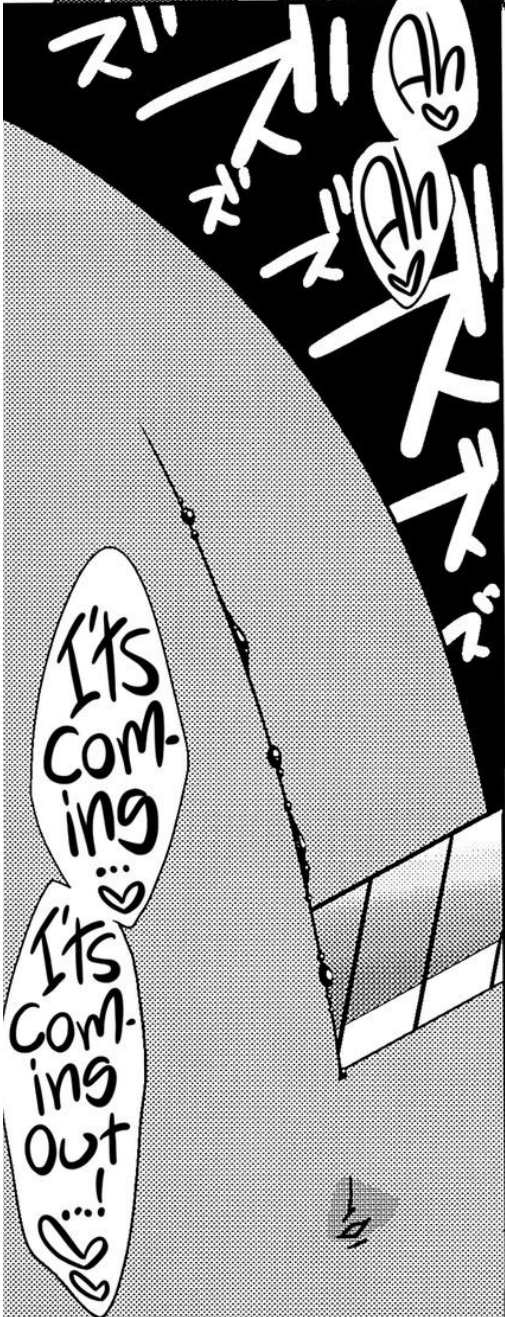
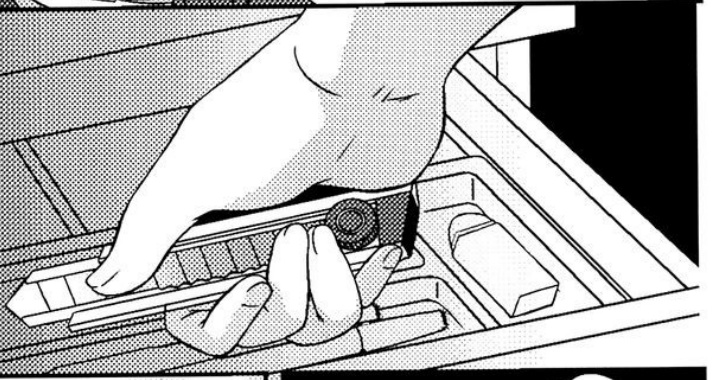

It's coming

It's coming out



Ah







TAKKUN... YOU'VE ALWAYS BEEN SUCH A PERV~

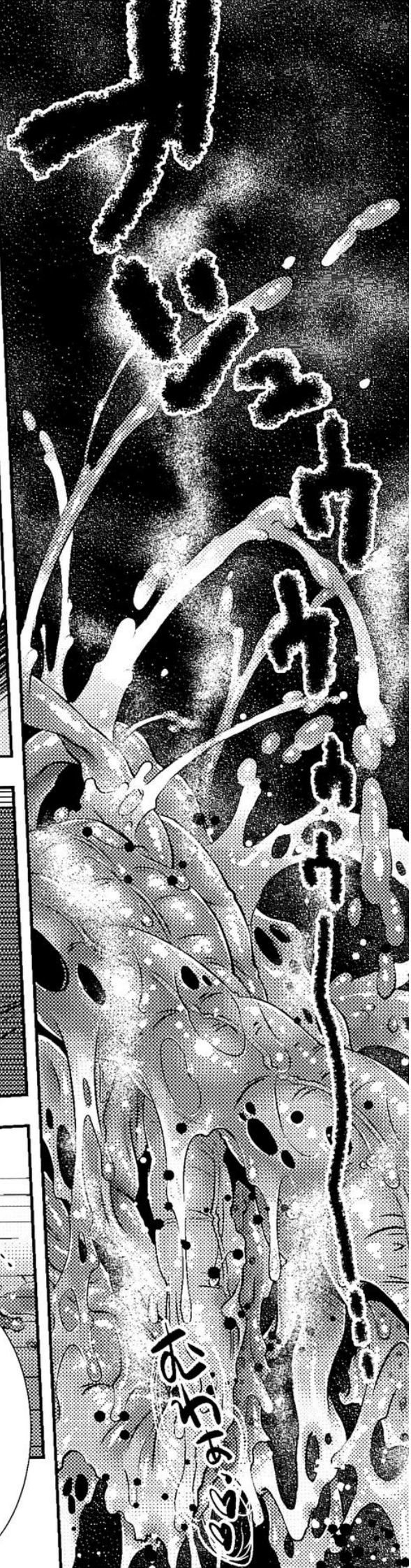

I CAN'T BELIEVE YOU'D CUT YOUR CHILDHOOD FRIEND'S STOMACH OPEN...

AND GET A BONER WHILE DOING IT~

LOVE FEELING THE DECOMPOSITION GASES AND FLUIDS SPREADING AROUND, DON'T YOU?

YOU ...

WHAT WAS THE WORD FOR THIS AGAIN? SOMETHING-PHILIA?

The End

氏賀Y太自薦傑作選

# 致死曆

ち

し

ごよみ



最新刊にして

最旧刊。



氏賀Y太のデビューからの数ある猟奇漫画作品の中から  
作者が特に気に入っている作品を厳選して掲載する第一弾！  
加えて40Pの単行本未掲載作品「カモ次郎の野宮生活」も掲載！  
出版：(株)ジーウォーク ムーグコミックス

発売日：2017/08/04

←amazonでの購入はこちらをチェック(懇願)



**MOST BRUTAL ARTWORKS**

# **UZIGAYA WORKS**

## **Doku Doku Vol.14 "Moonlight Camellia Final"**

Publishing Date: 2017/08/13

Production: Uzigaya

Publisher: Uziga Waita

Mail: [uzigaworks@gmail.com](mailto:uzigaworks@gmail.com)

Twitter ID: uzigawaita

Printing: Neko no Shippo

This doujinshi is copyrighted by Uzigaya.  
You are strongly prohibited from making unauthorized copies of it, or uploading it on the internet.

Special Thanks to Momoiro Manjiru, thank you very much!

# 毒毒第拾四号 月光椿完結編

## 氏賀屋

