

I Love New York.  
Welcome to the soap land!!

# 湯けむりのカンカンアソビ

天野しゅにんた

yh COMICS  
湯けむりのカンカンアソビ

天野しゅにんた  
IDC 一迅社



ISBN978-4-7580-7064-5  
C9979 Y857E

一迅社  
雑誌 50661-98  
定価: 本体857円+税



I ♥  
入浴

I Love New York,  
Welcome to the soap land!!

# 湯けおけ カンパチユアム



天野しゅんた



9784758070645

ISBN978-4-7580-7064-5

C9979 ¥857E



1929979008574

一迅社

雑誌 50661-98

定価: 本体857円 + 税

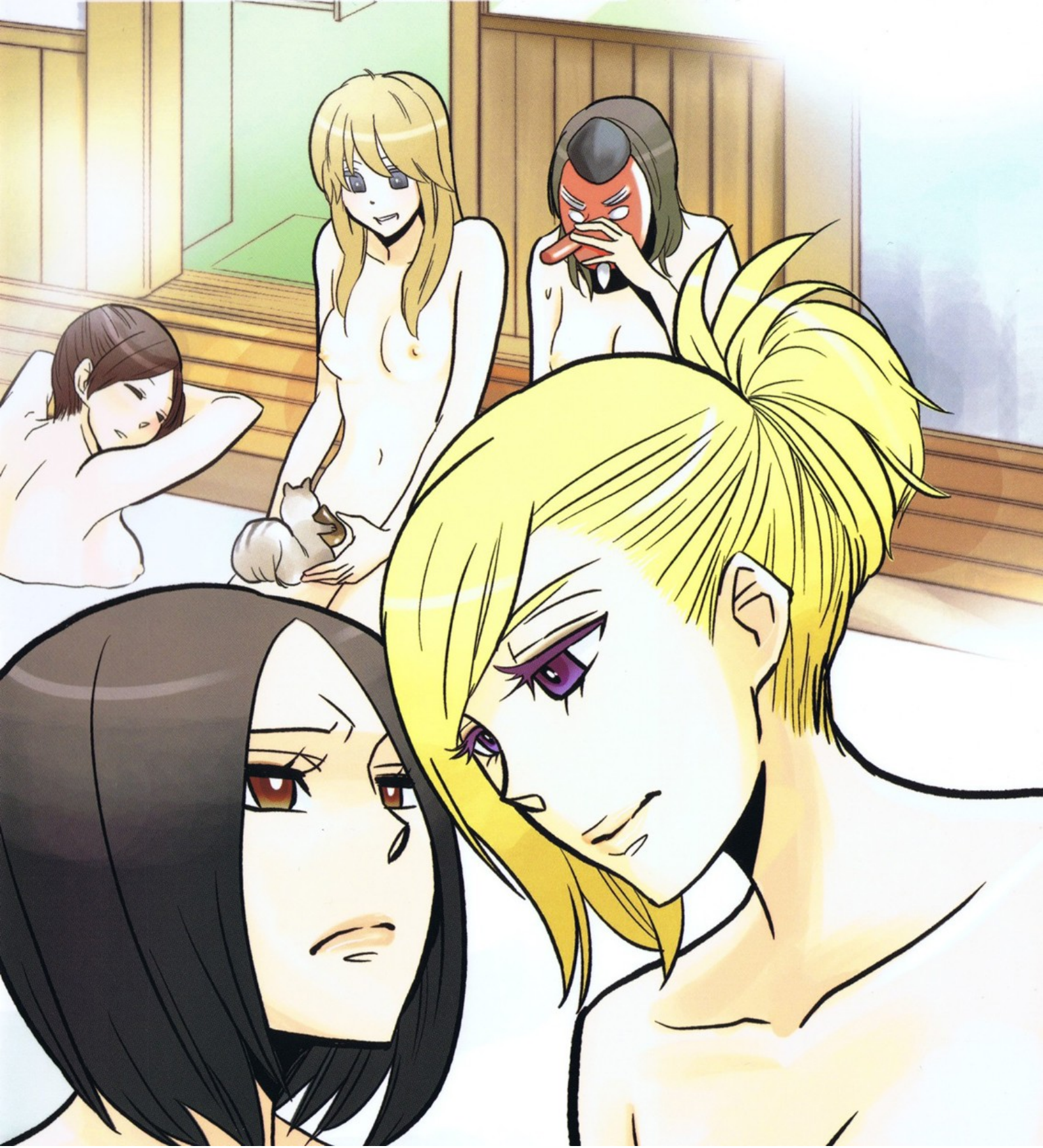



天野しゅにんた

Syuninta Amano

こんにちはーはじめまして！  
デビュー単行本です！  
ペンだこもデビューしました！  
びびりうれしはずかしです！  
頭ユルめの女子12種(6組)  
しっぽりお楽しみあれ☆



## CONTENTS

🔥 1泊目 🔥	
「バイト仲居半人前奮闘記」	003
🔥 2泊目 🔥	
「温泉ストリッパー修行録」	023
🔥 3泊目 🔥	
「湯けむりアイドル慕情」	043
🔥 4泊目 🔥	
「みちのく魅惑の秘宝館」	063
🔥 5泊目 🔥	
「OL二人しっぽり社員旅行」	083
🔥 6泊目 🔥	
「若女将つれづれ初恋旅情 前編」	103
🔥 7泊目 🔥	
「若女将つれづれ初恋旅情 後編」	123
あとがき	143

- ストロベリーシェイクSweet全②巻……………林家志弦  
 初恋姉妹全③巻……………東雲水生(①脚本 駒尾真子)  
 絶対×浪漫……………むっちりむうにいい  
 ことのはの巫女とことだまの魔女と……………藤枝雅  
 少女美学……………CHI-RAN  
 春夏秋冬……………蔵王大志 原作:影木栄貴  
 乙女ケーキ……………タカハシマコ  
 かわいいあなた……………乙ひより  
 南波と海鈴①-②……………南方純  
 夜空の王子と朝焼けの姫……………袴田めら  
 秘蜜少女……………CHI-RAN  
 楽園の条件……………森島明子  
 マーメイドライン……………金田一蓮十郎  
 EPITAPH①……………硝音あや  
 アオイシロ-青い城の円舞曲-……………江戸屋ぼち 原作 麓川智之  
 紅蓮紀①-②……………武若丸  
 ときめき☆もののけ女学園①……………南国ばなな  
 クローバー……………乙ひより  
 極上♥ドロップス①-②……………三国ハチメ  
 半熟女子全②巻……………森島明子  
 カシオペア・ドルチェ①……………高木信孝  
 HONEY CRUSH①……………椿あす  
 flower\*flower①……………石見翔子  
 純水アドレッセンス……………かずまこを  
 Sweet Peach!-スイートピー!-①……………水野透子\*千手ちゆ  
 愛しをとめ~君がここは~……………高橋依摘  
 熱帯少女……………吉富昭仁  
 BUTTERFLY69……………夏猫  
 リンケージ……………倉田嘘  
 この願いが叶うなら……………袴田めら  
 百合心中~猫目堂ココロ譚~……………東雲水生  
 瑠璃色の夢……………森島明子

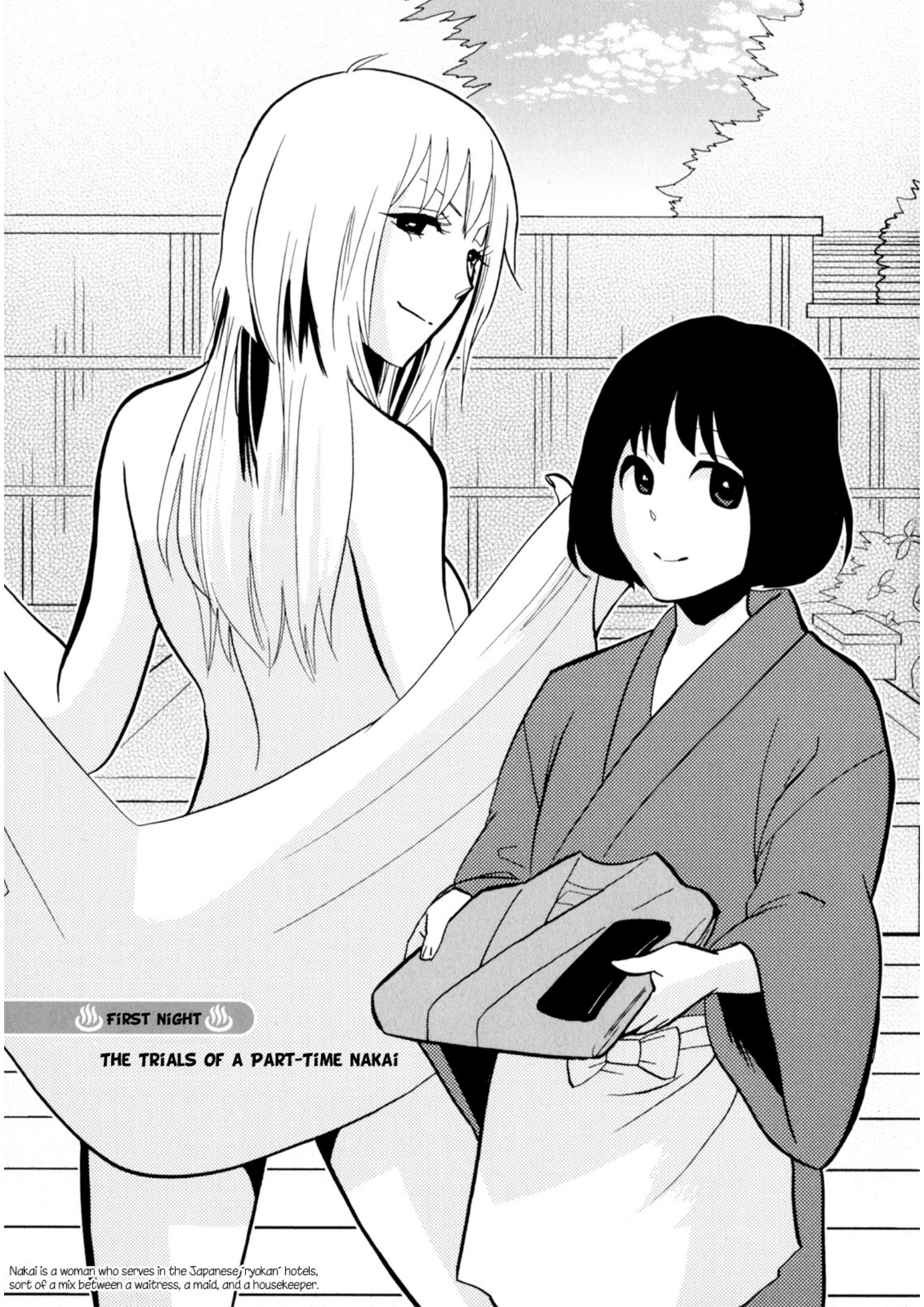

🌀 FIRST NIGHT 🌀

### THE TRIALS OF A PART-TIME NAKAI

Nakai is a woman who serves in the Japanese, "ryokan" hotels, sort of a mix between a waitress, a maid, and a housekeeper.

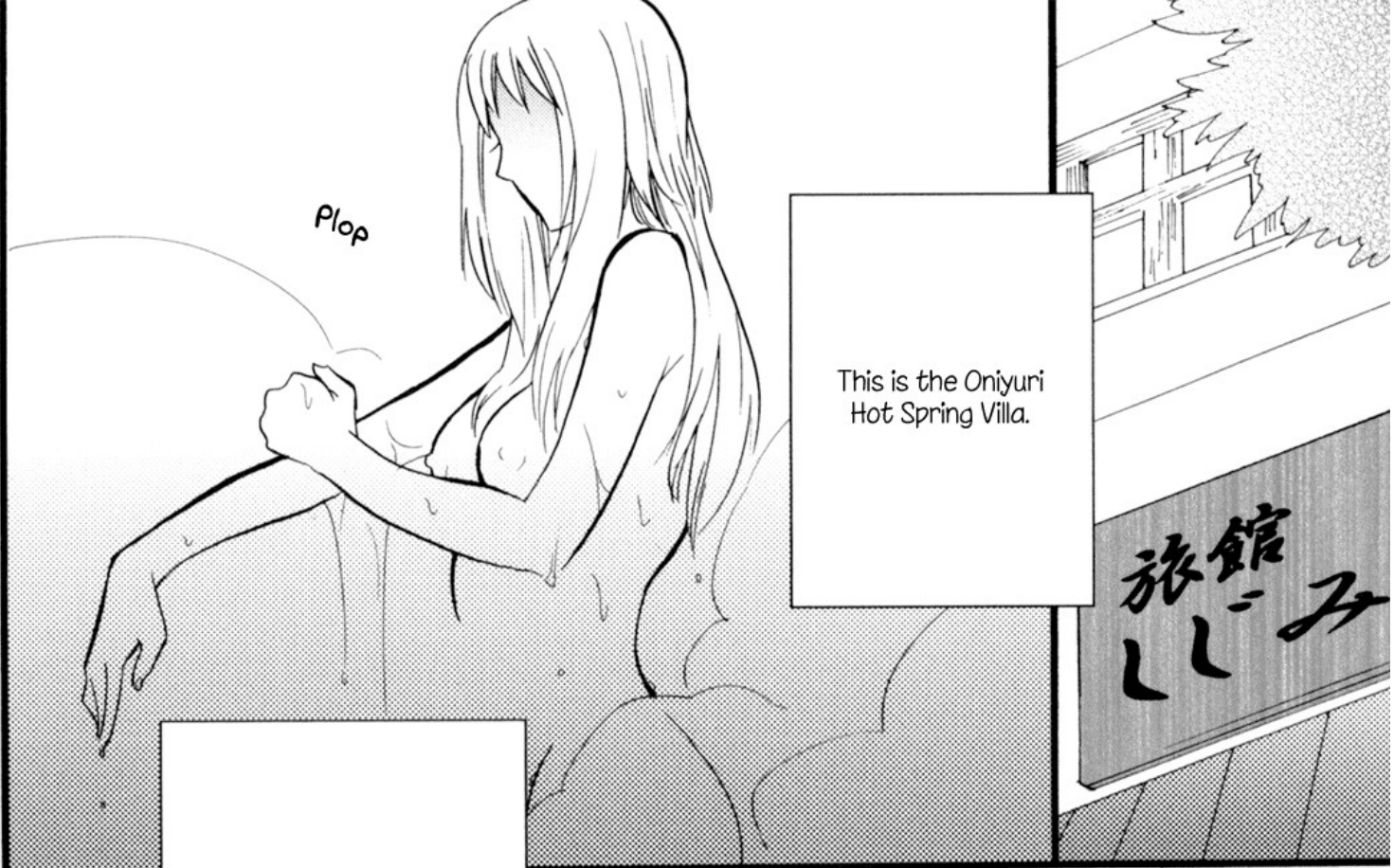

Plop

This is the Oniyuri Hot Spring Villa.

旅館  
しし

A rejuvenerating sanctuary, lost amidst the steam-



and forgotten by time.



pant...

pant...

And from one particular inn here-



RUSTLE

RUSTLE

RUSTLE

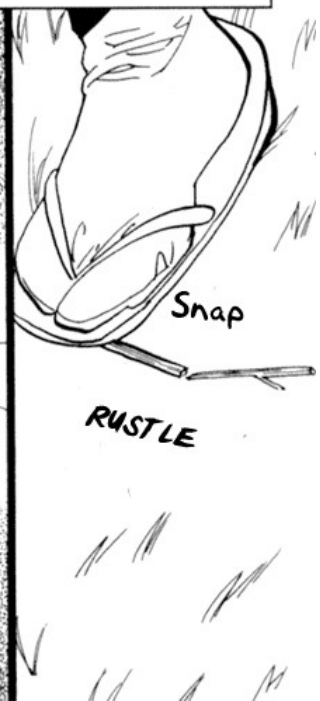

Snap



I SHOULDN'T HAVE COME...

THERE'S NOTHING HERE...



I'M LOST...

A nakai attempts her escape!

Part-time Nakai Ichi (19)



Grandma is so cruel...



If you're going to lay around doing nothing, GO GET A PART-TIME JOB AND LIVE THERE!!  
Ehhhh!

Garr!  
Hey Ichi!



Bump!

OW!



Slide

GYAAAA!



OWW... WHAT SHOULD I DO? WHICH WAY SHOULD I...



slip

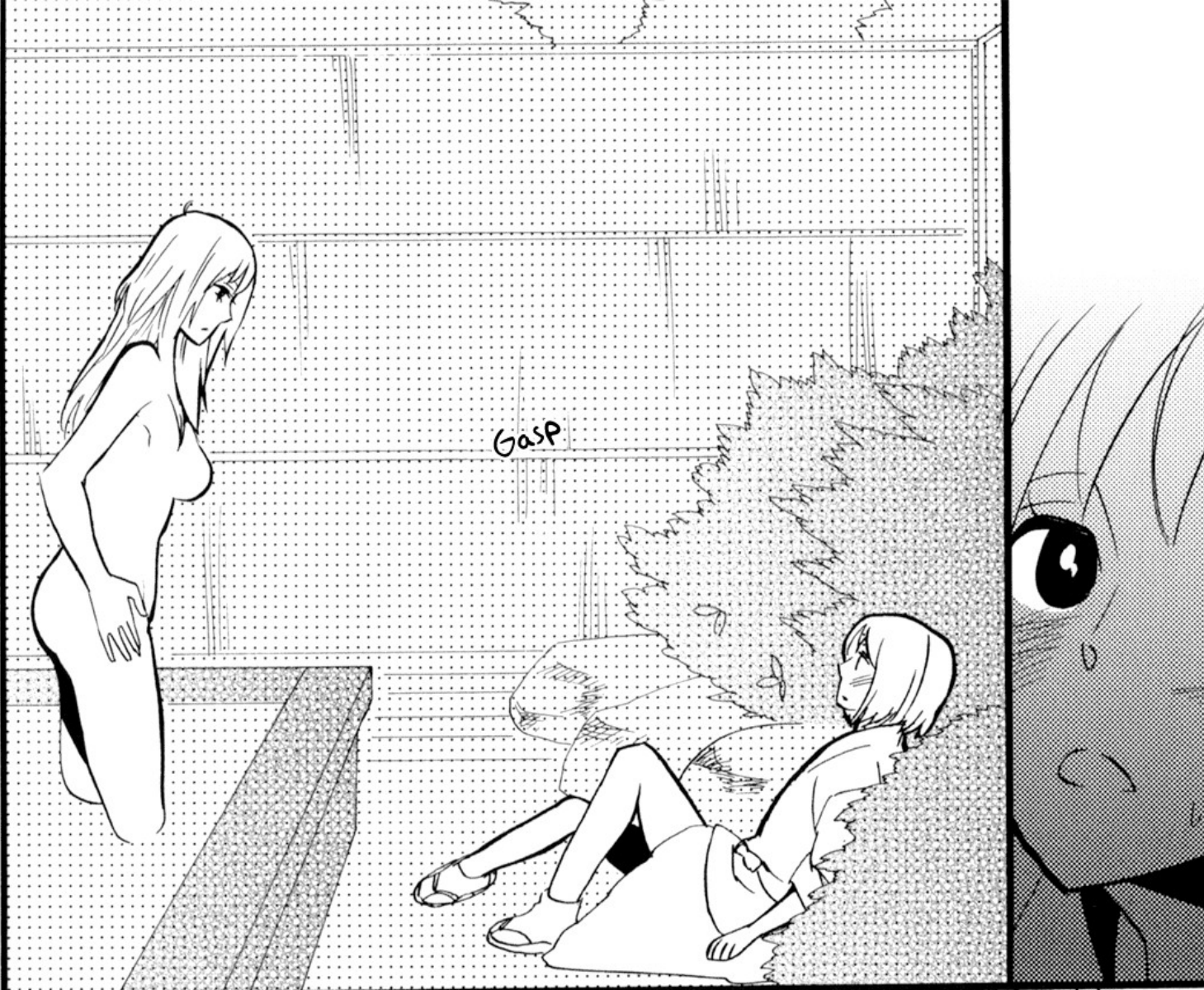

Gasp



HEY, NAKAI-SAN...  
ARE YOU OKAY?

You're  
covered  
in mud.

EEEP!  
I'M SO  
SORRY!

Waaah!



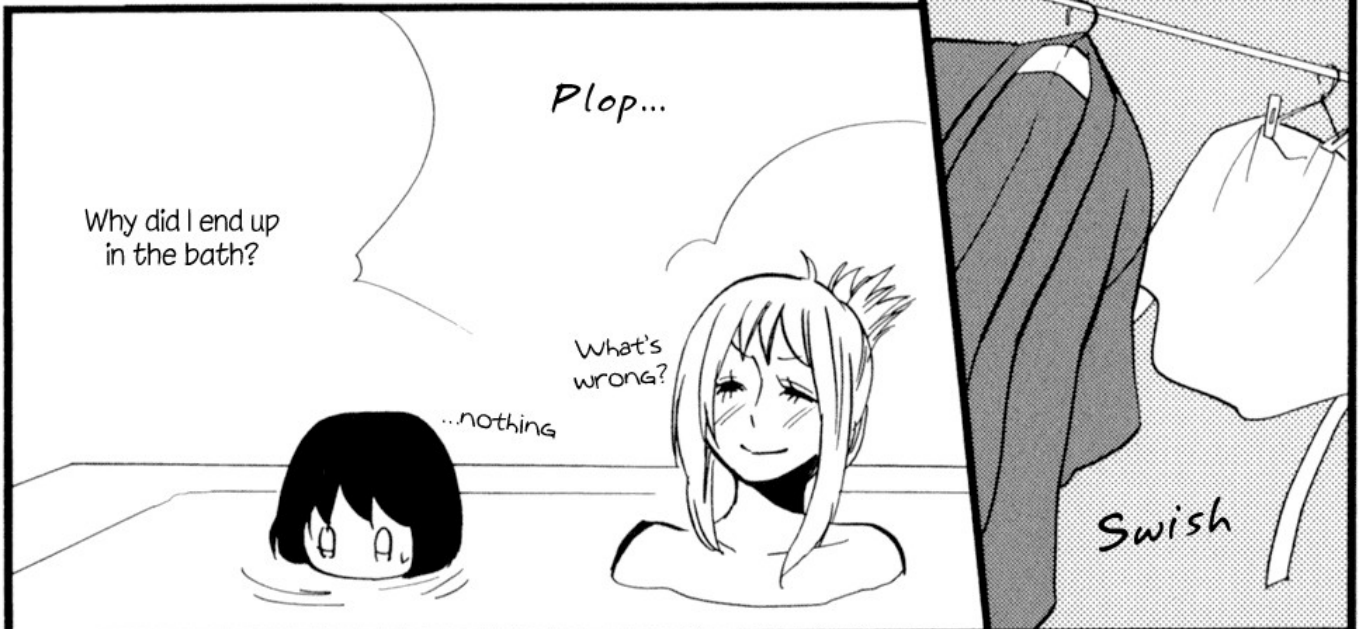

Why did I end up in the bath?

Plop...

What's wrong?

...nothing

Swish



...DO YOU THINK SO?

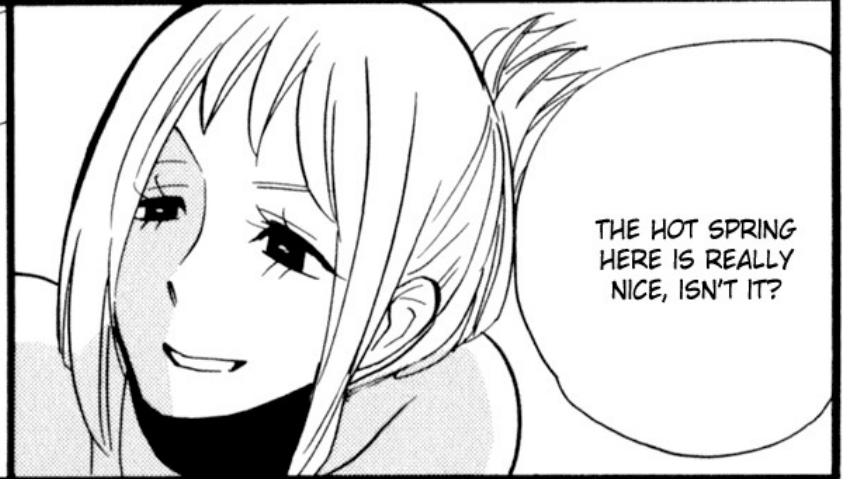

THE HOT SPRING HERE IS REALLY NICE, ISN'T IT?



I REALLY LOVE IT HERE.

WELL... NOT EXACTLY.

Your skin is so smooth without doing a thing. So young!

HUH, YOU'RE NOT INTERESTED IN HOT SPRINGS?



WHAT ARE YOU TALKING ABOUT?

AND IT'S NOT FAMOUS AT ALL—

THERE ARE HARDLY EVER ANY CUSTOMERS HERE.

REALLY?



WELL, I GUESS YOU COULD CALL IT THAT.

I SAY SO, AND I'VE BEEN AROUND THE HOT SPRINGS ALL OVER JAPAN.

REALLY? ARE YOU A HOT SPRING MANIAC?

Splash



HAVING MORE PEOPLE DOESN'T ALWAYS EQUATE TO BEING A BETTER PLACE.



SO SHE KNEW...

THANK YOU VERY MUCH...

Swish

I WON'T SAY A THING ABOUT YOUR ESCAPE, SO TRY HARDER NEXT TIME.



ALRIGHT THEN! GOOO! ICCHAN!

...UM OKAY...



I'M ICHI.



TELL ME YOUR NAME.

I'M YAMAMOTO.



YES...

Oh, owner...

BUT COULD YOU CLEAN UP THE DRESSING ROOM?

ICCHAN, SORRY TO ASK WHILE YOU'RE SO TIRED,

SIGH...

Exhausted



BEING A NAKAI IS A HARD JOB,

ISN'T IT?



I GUESS SO, BUT...

ONCE YOU FIND HAPPINESS IN SERVICE...

YOU'LL THINK THIS IS A WONDERFUL JOB.



I WONDER...

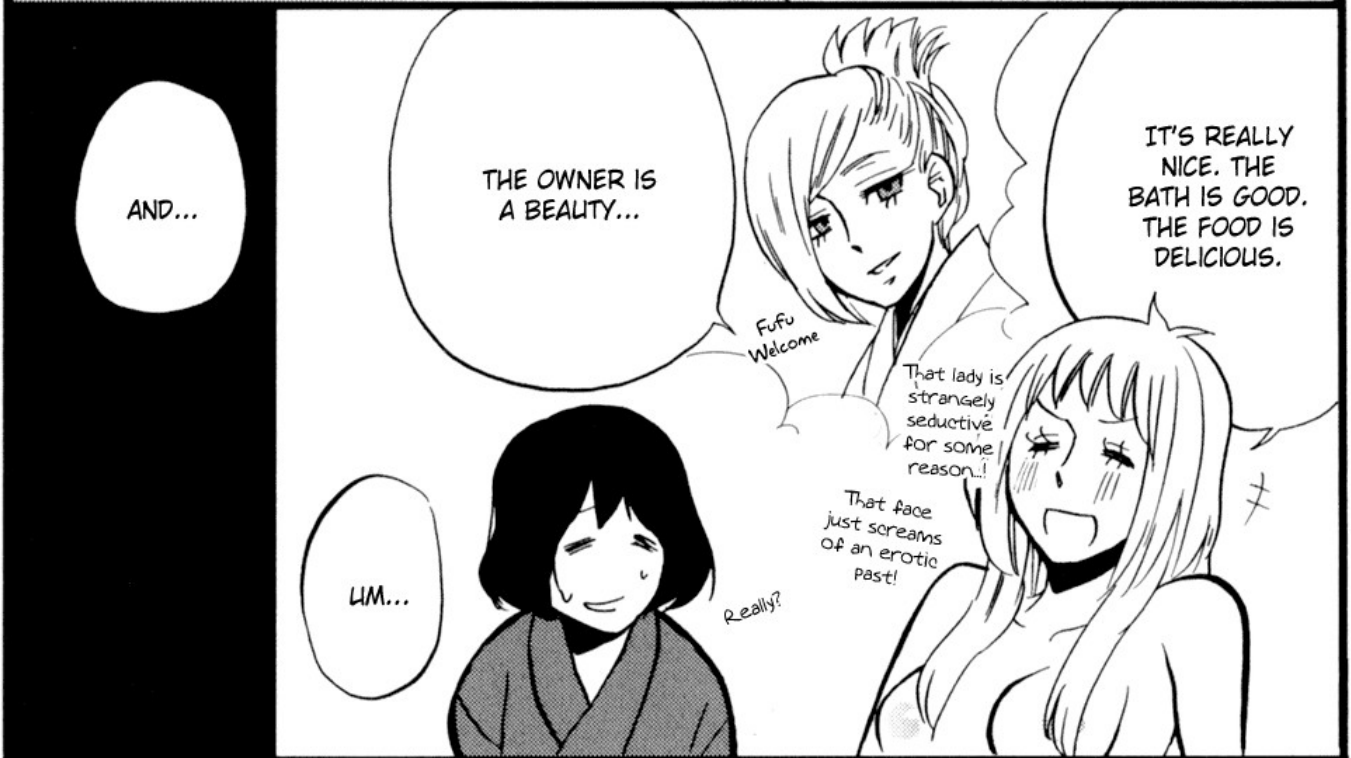
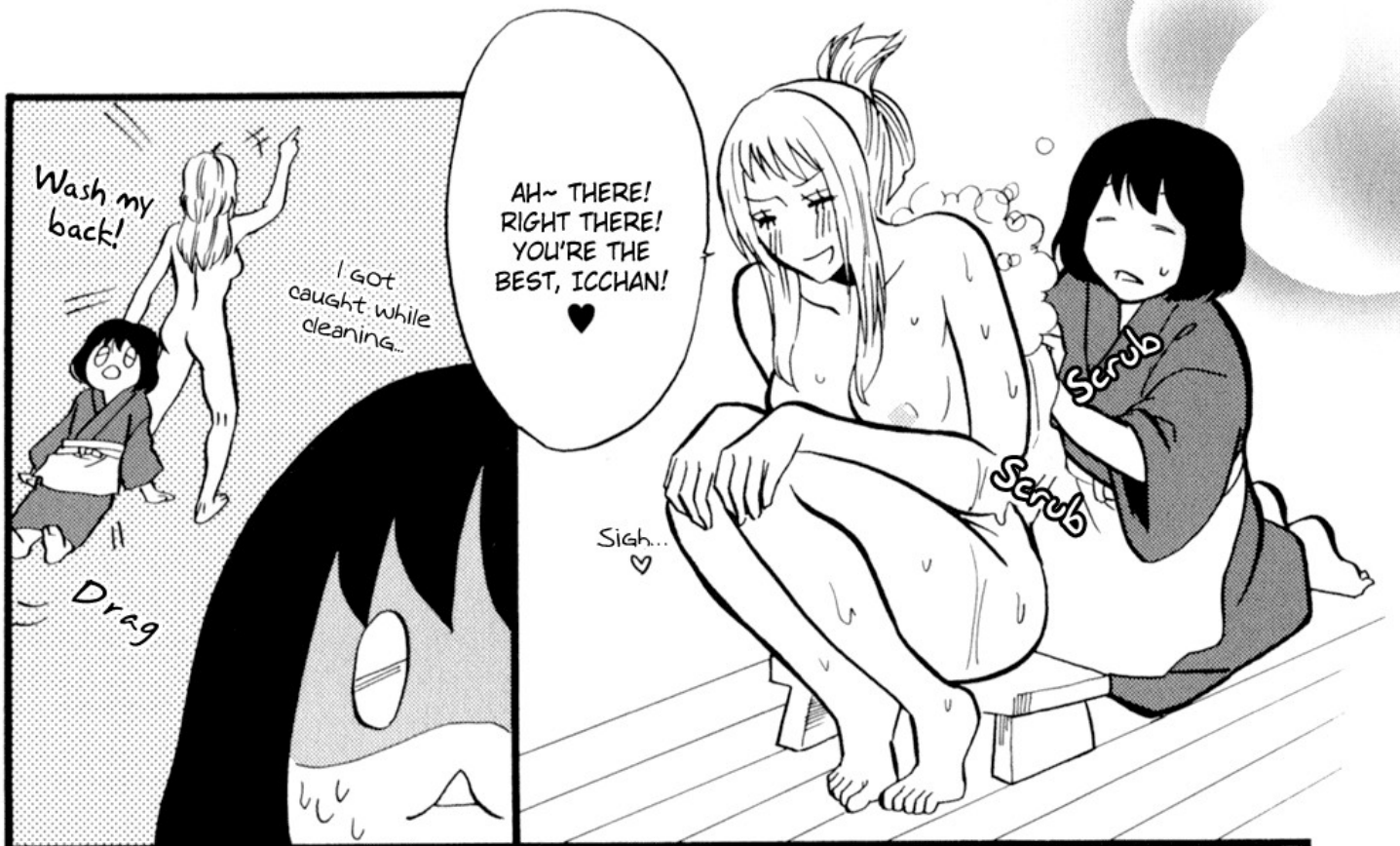



REALLY  
NOTHING  
SPECIAL...

WHA...  
I'M...



JUST RECENTLY, AN  
EXCEPTIONALLY CUTE  
NAKAI-SAN STARTED  
WORKING HERE!



I'M NO  
DIFFERENT  
FROM ANY  
OTHER NAKAI.



YOU ARE  
SPECIAL.



BUT I REALLY DO  
THINK ICCHAN IS  
EXCEPTIONALLY  
CUTE, YOU KNOW?

WHAT IS SPECIAL  
TO ME IS UP TO ME  
TO DECIDE.

**P... PLEASE  
EXCUSE ME!**

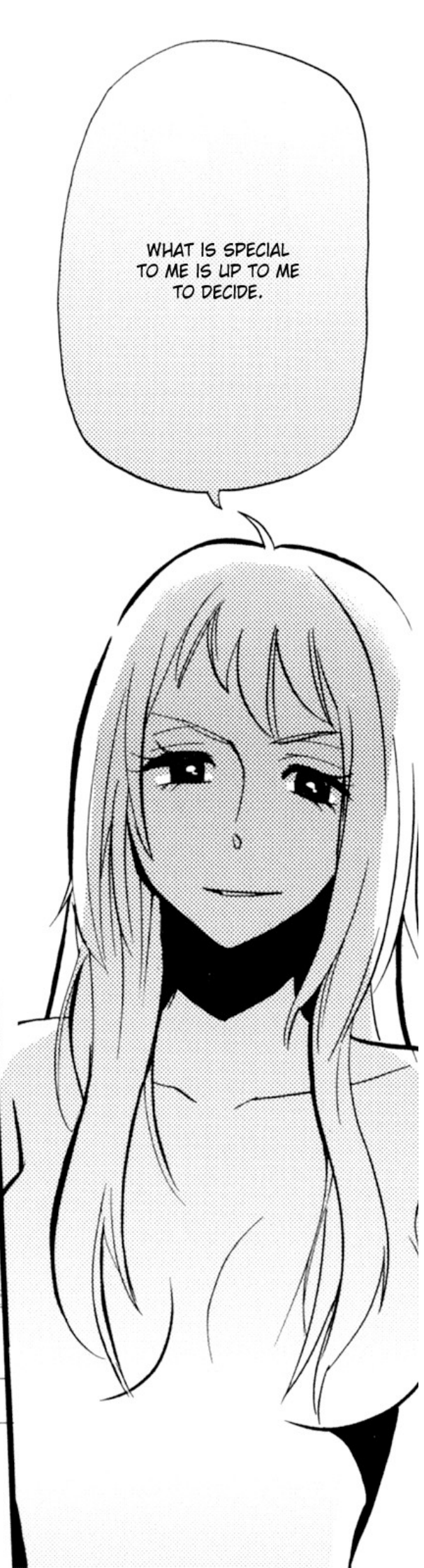

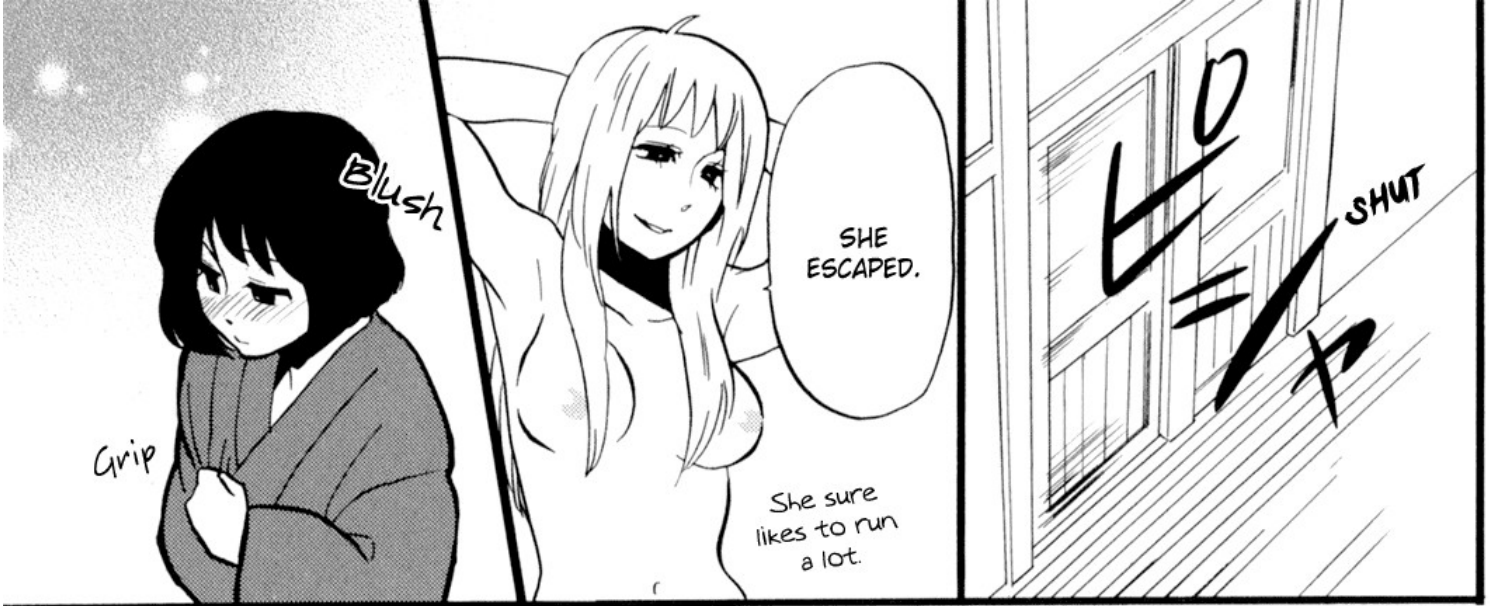

Grip

Blush

SHE ESCAPED.

She sure likes to run a lot.

SHUT



HERE, TAKE THIS. YOU'RE WORKING AT THE OUTDOOR BATH TONIGHT.

YES? WHAT IS IT?



ICCHAN!

CAN YOU COME HERE FOR A SECOND?

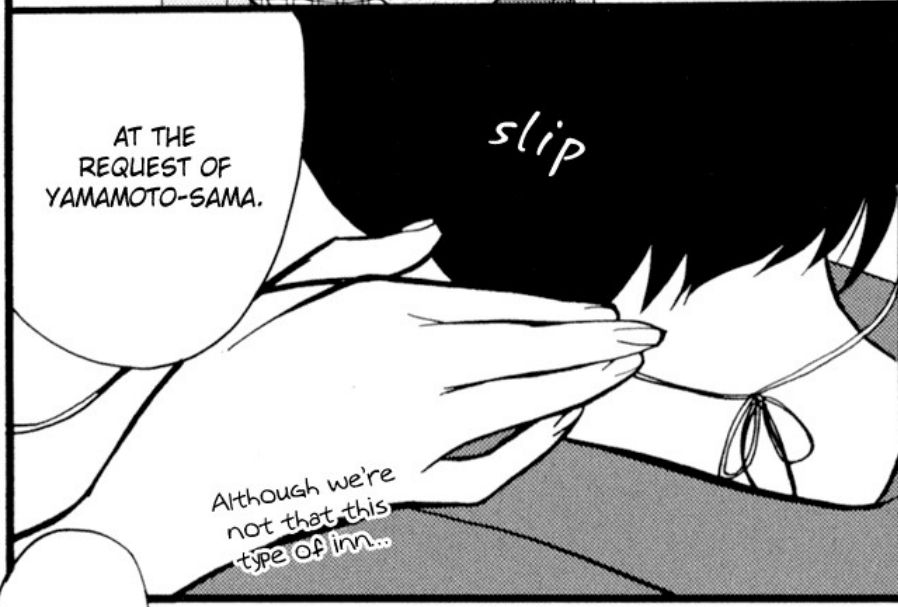

AT THE REQUEST OF YAMAMOTO-SAMA.

slip

Although we're not that this type of inn...



HUH?

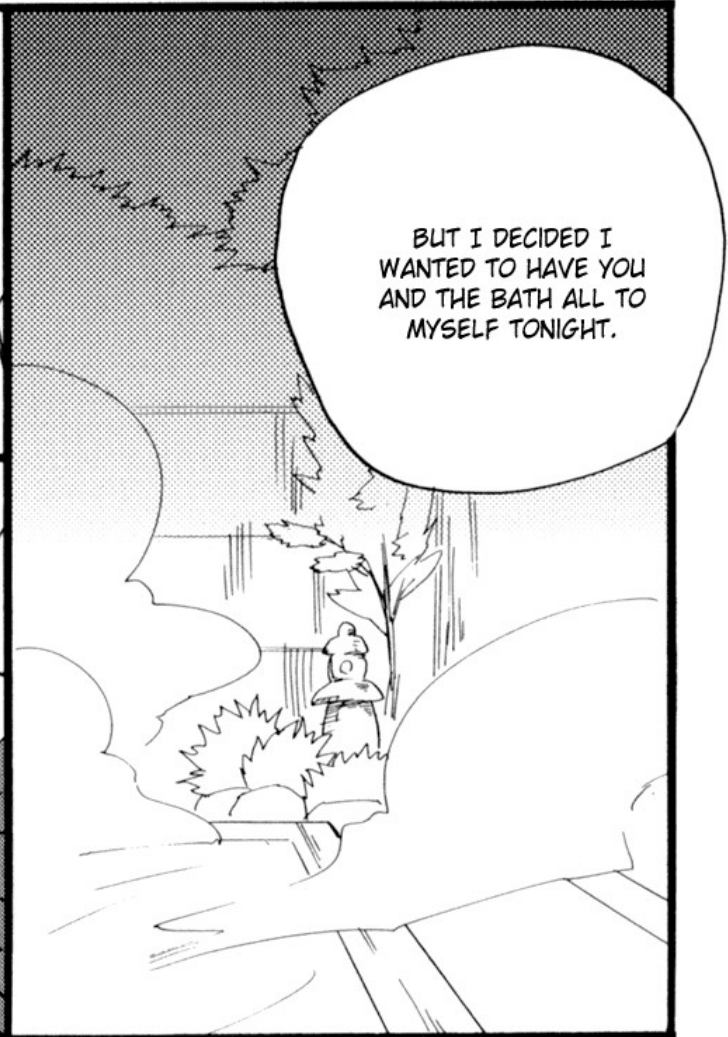
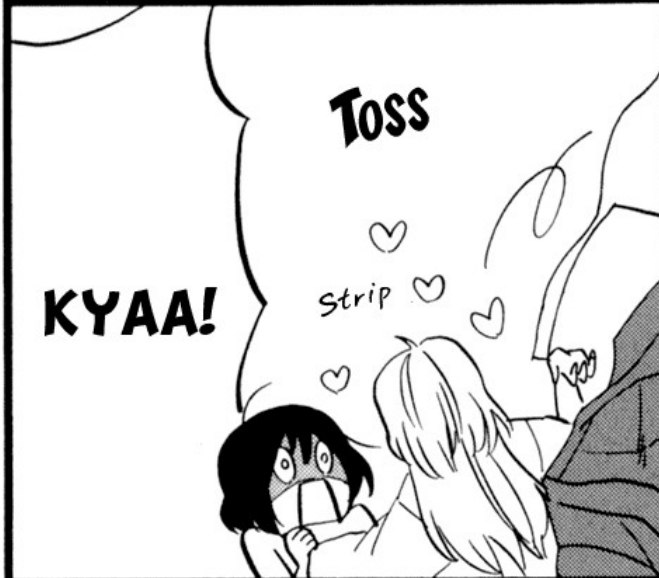



SO MANY STARS...

RIGHT?

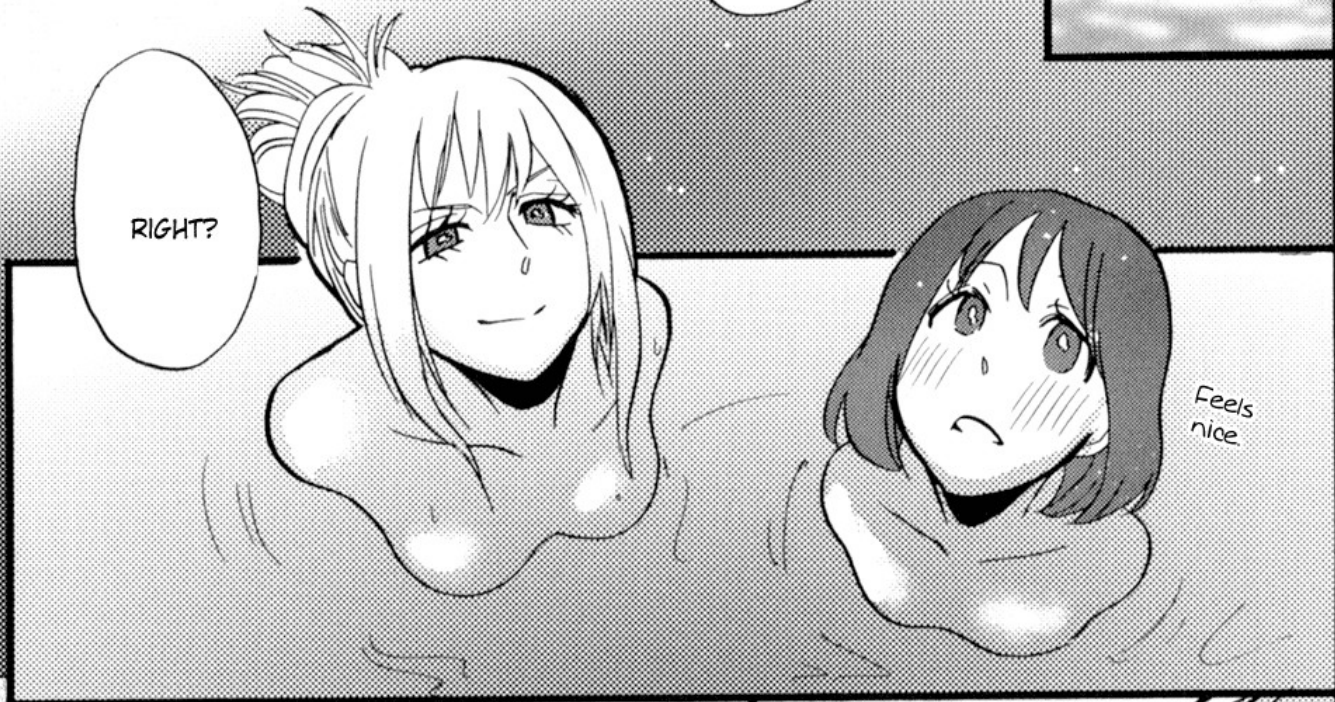

Feels nice

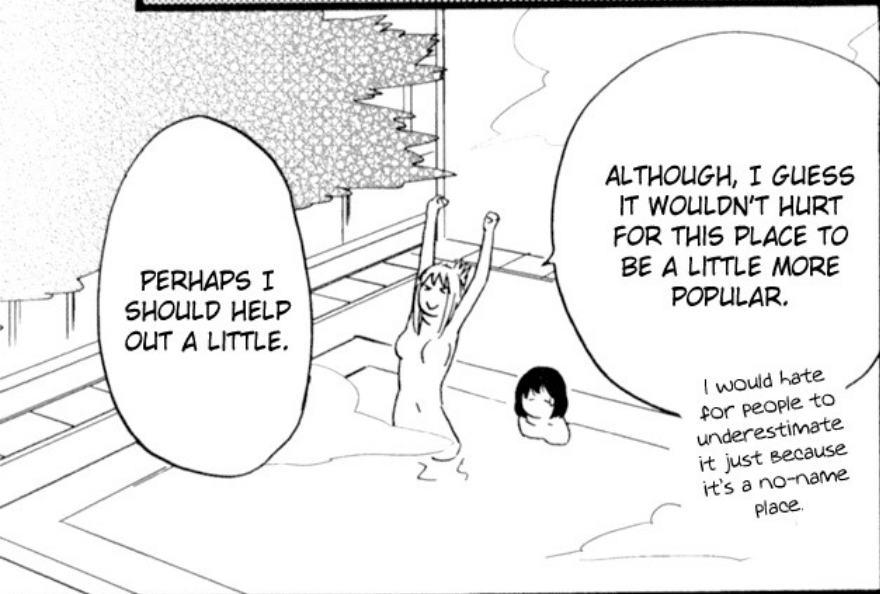

PERHAPS I SHOULD HELP OUT A LITTLE.

ALTHOUGH, I GUESS IT WOULDN'T HURT FOR THIS PLACE TO BE A LITTLE MORE POPULAR.

I would hate for people to underestimate it just because it's a no-name place.



FAMOUS NAMES OR NO-NAMES...

DON'T YOU THINK IT DOESN'T MATTER?



WHO ARE YOU, YAMAMOTO-SAN?  
Are you some kind of important person?

WHAT?

BUT MAYBE I SHOULD START PUBLI-CIZING LIKE CRAZY FROM NOW ON.

I NEVER WROTE AN ARTICLE ABOUT HERE BECAUSE I LOVED IT SO MUCH...

I just write for magazines.

I'm not in any position of power...

I'M A JOURNALIST, SPECIALIZING IN HOT SPRINGS REVIEWS.

WHAAAT?

WHAT YOU SAID ABOUT THE OWNER MAY BE TRUE, BUT I'M COMPLETELY AVERAGE.

Here you go, saying stuff like that again.

THIS PLACE WILL BE SO POPULAR WITH SUCH A BEAUTIFUL OWNER AND AN INCREDIBLY CUTE NAKAI.

Glide

Touch

TO ME, YOU ARE...

VERY SPECIAL, ICCHAN.

A SPECIAL SERVICE.

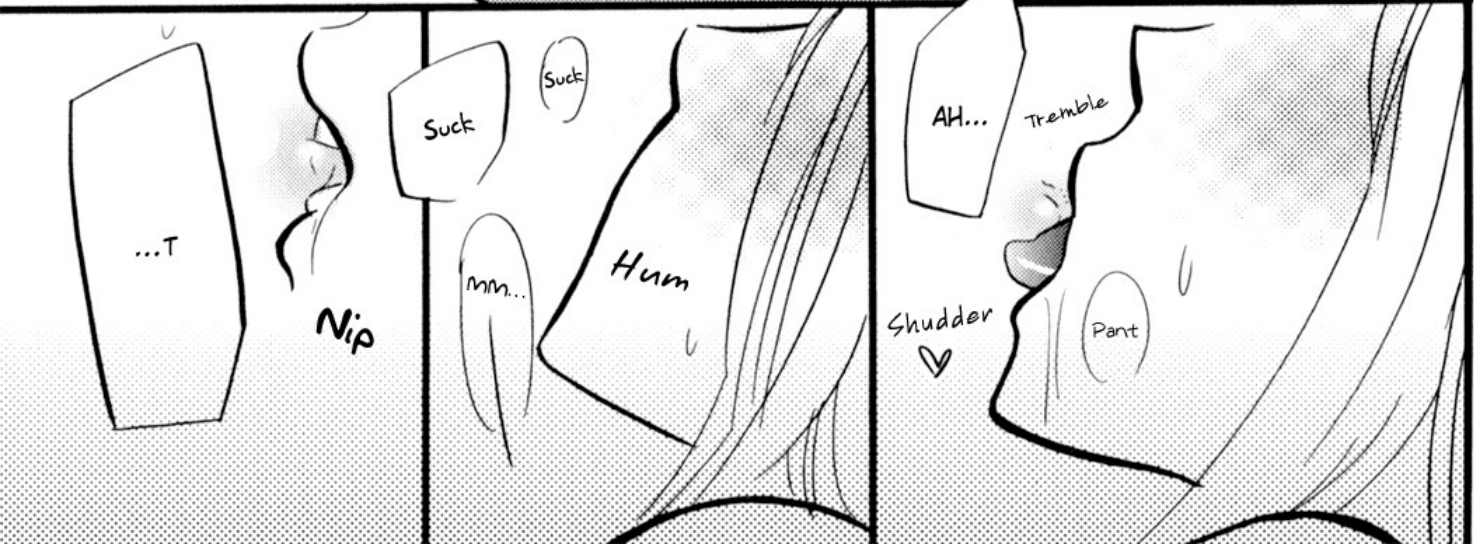
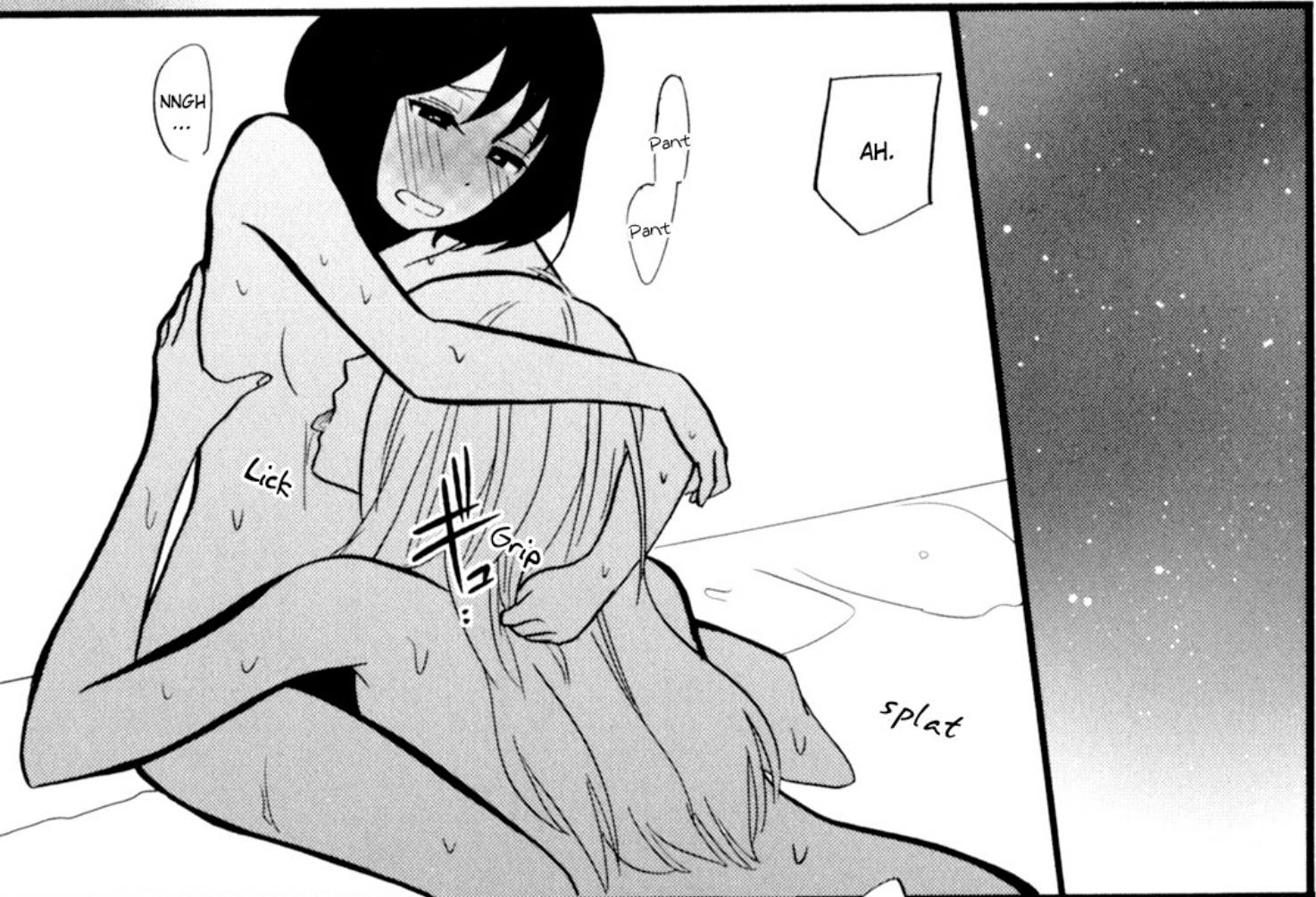
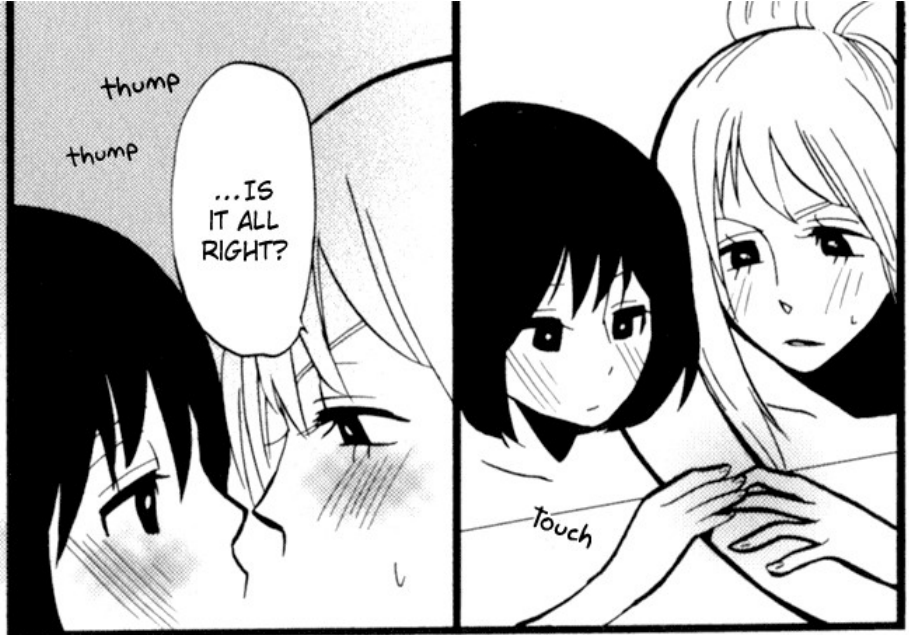

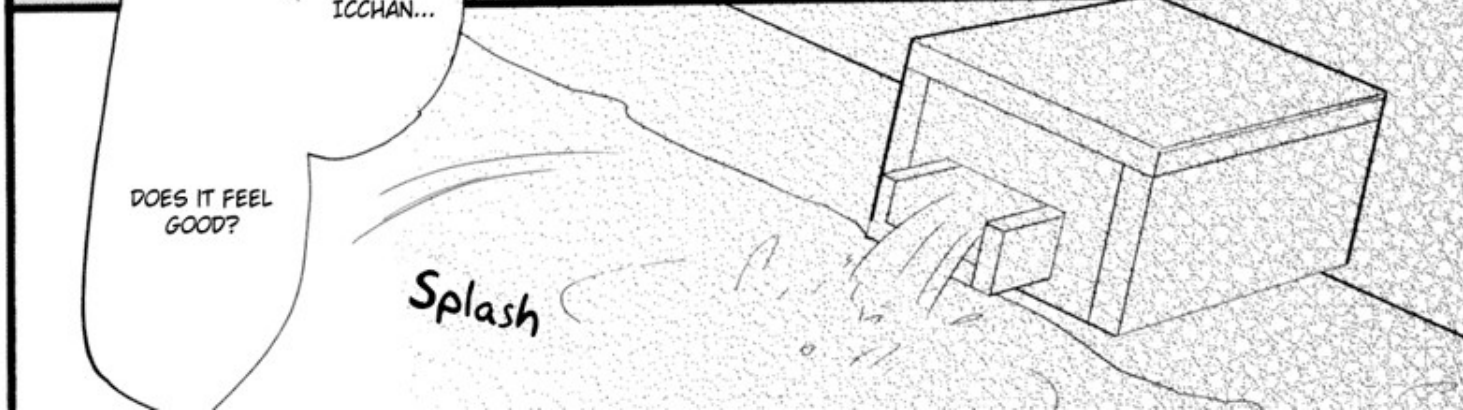
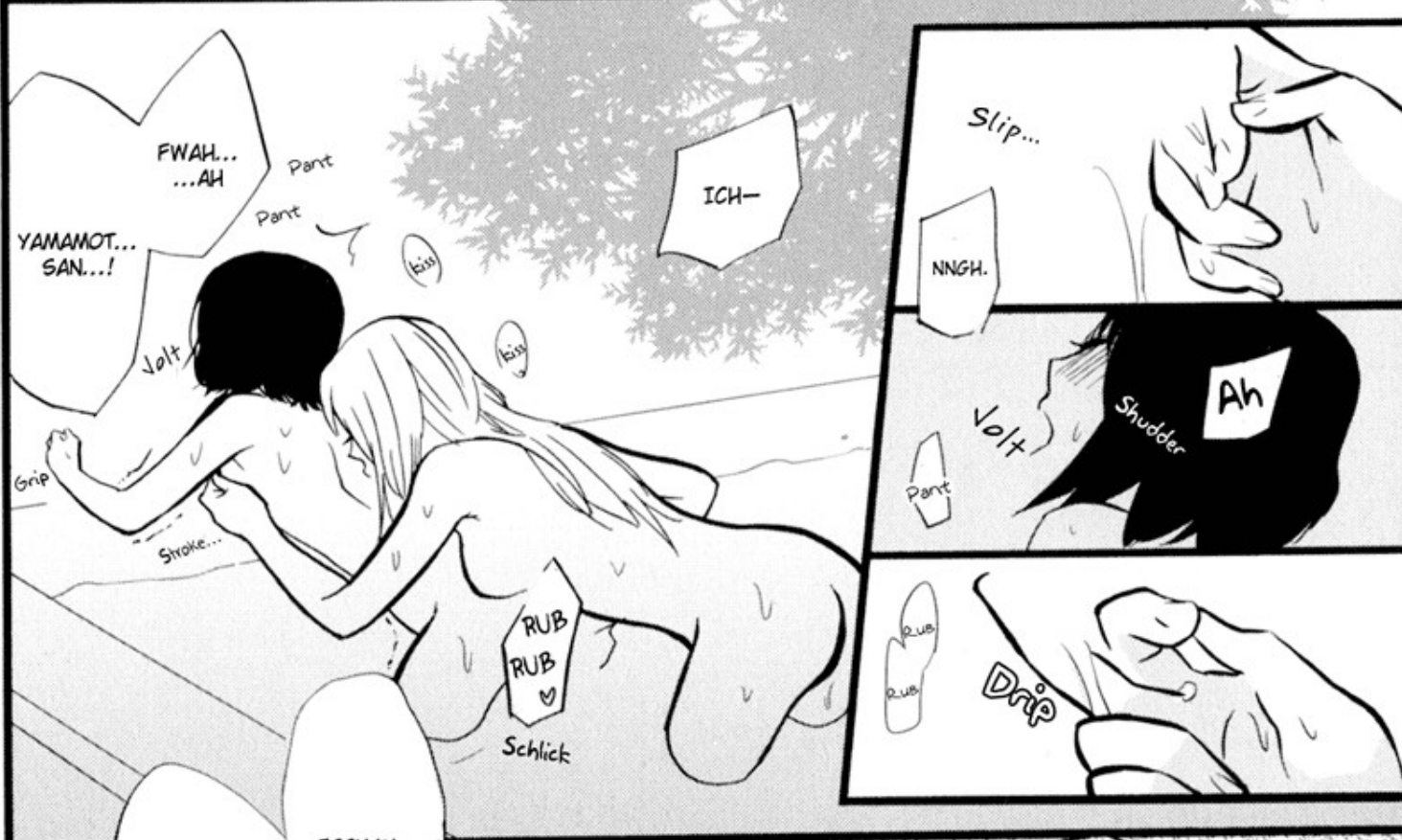
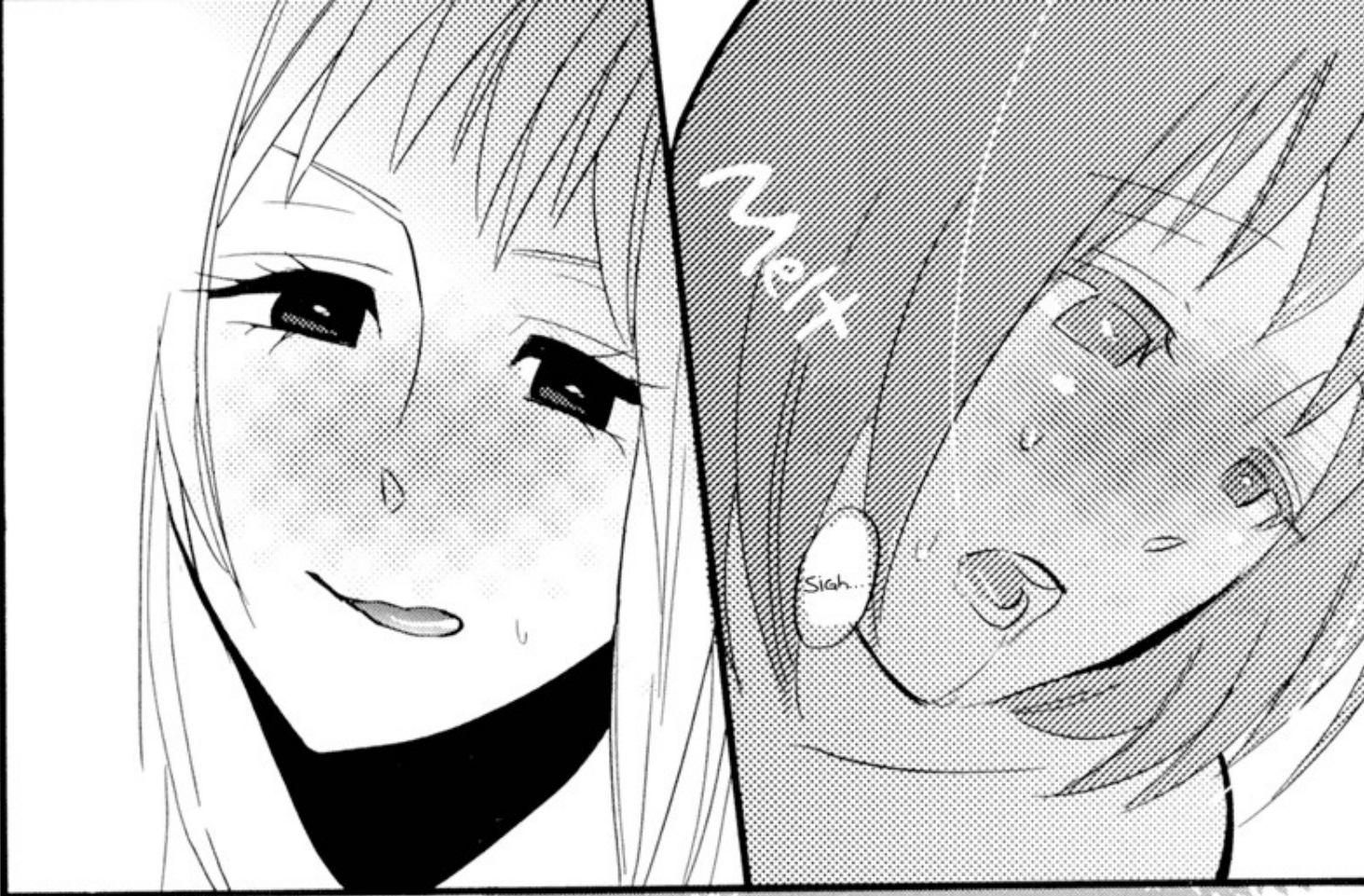



IT FEELS...

GOOD...  
NGH~

I'M GLAD...

I realized that  
seeing Yamamoto-  
san's happy face,

was making me  
happy as well.



thump..

Pant  
Pant

quite the same as your "happiness in service"?

I guess this isn't

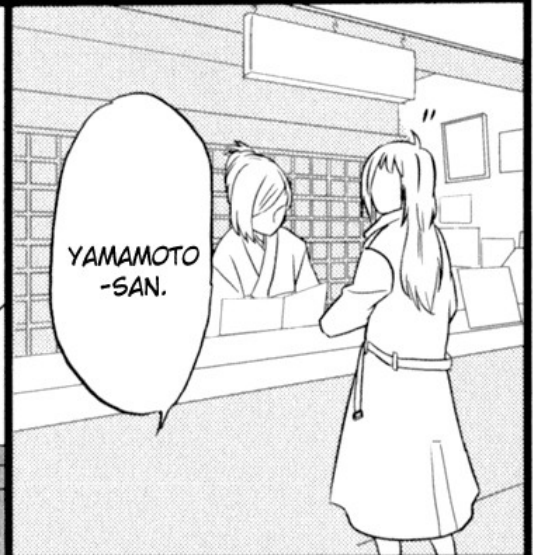



I LOOK FORWARD TO YOUR NEXT VISIT!

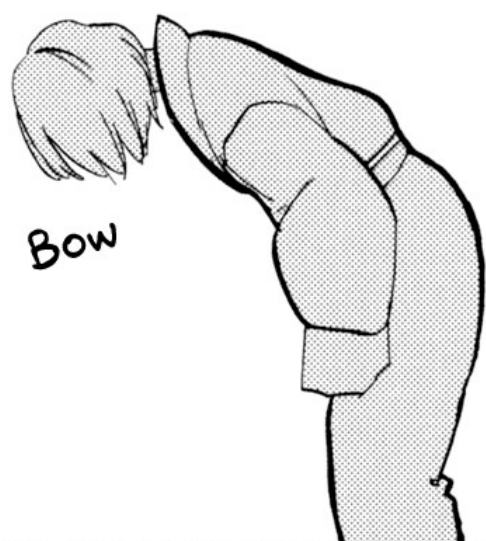

Bow

Sniff



THANKS TO YOU.



Haha ♡

ICCHAN IS ACTING SO MUCH LIKE A PROPER NAKAI-SAN NOW!

...HEY,  
ICCHAN.



She's gone...

Sniff



SEE YOU, THEN.

WELL...



The background features a faint, light-colored illustration of several anime-style characters. In the foreground, there are two more prominent characters: one with long brown hair and green eyes looking upwards, and another with short brown hair and red eyes looking forward with a surprised expression.

Yukemuri Sanctuary - Chapter 01

Raws: Audio Erotica

Translator : Hitsuji-san

Proofreader : Babelglyph

Editor: Kite

Quality Checker: Audio Erotica

[www.tranquilspring.com](http://www.tranquilspring.com)

[www.Payapaya-Scans.com](http://www.Payapaya-Scans.com)

Visit Payapaya's IRC channel at:

#Payapaya @ rizon.net





Hey lady

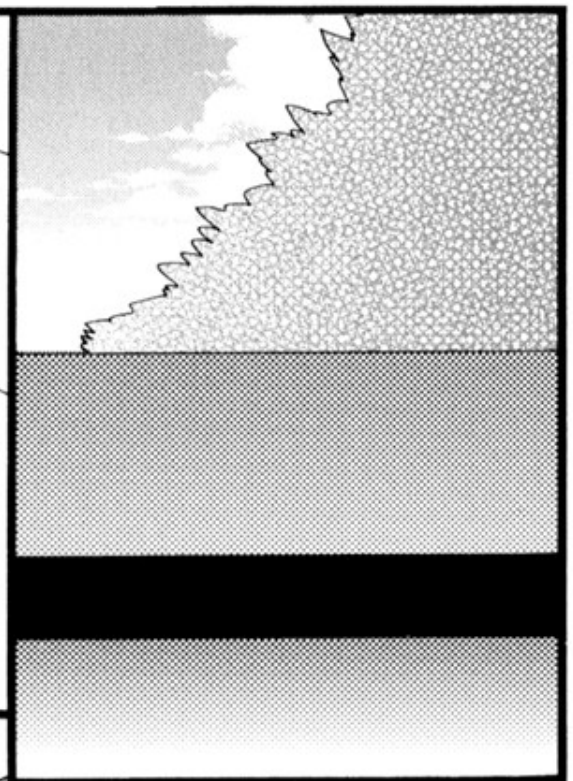

Higairi Open Air Hot Spring Tamaki



I'm Tamaki Aoi.

I run a hot spring day spa with my grandma.

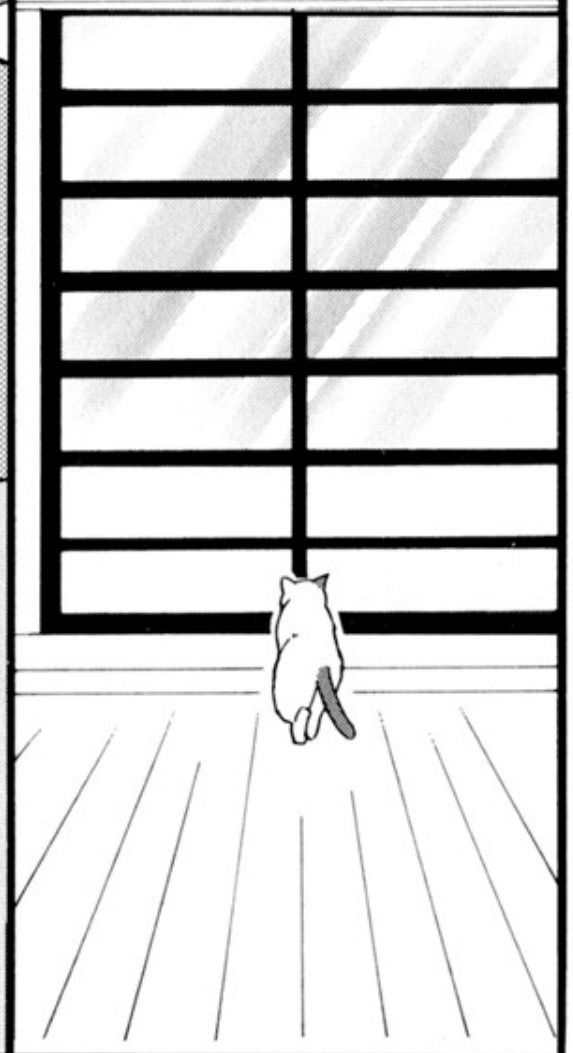

We take it easy,  
dealing mostly with  
the local old folks.

This will help us  
live longer...

So nice

Sleatth

Because there  
have been so few  
tourists in the last  
few years, it's  
more like a public  
bathhouse now.

Just the other day,  
a local TV station  
came by to tape it.

Cat  
Spring

Lick  
Lick

Rub  
Rub

Wash  
Wash

About the only  
thing of interest is  
a cat that comes  
to take baths in  
our springs...

OH!

Excuse me

WELL  
THEN, GUESS  
I'LL CHECK  
THE WATER  
TEMPERATURE.

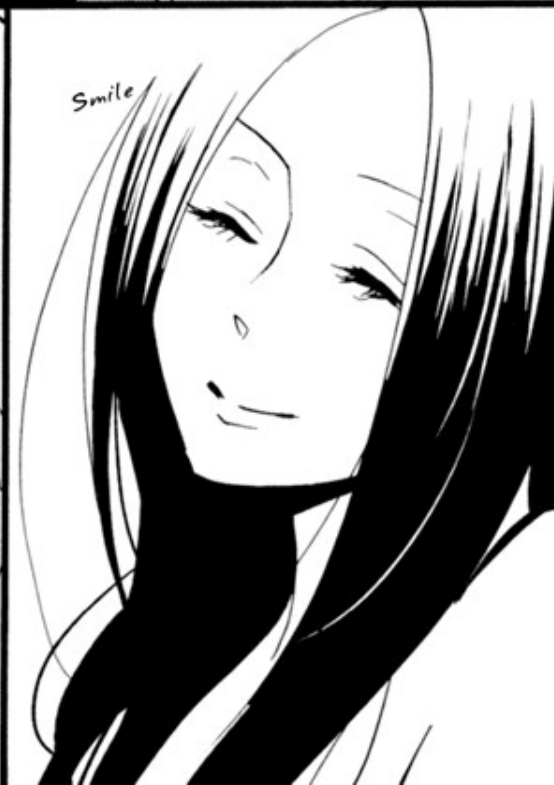
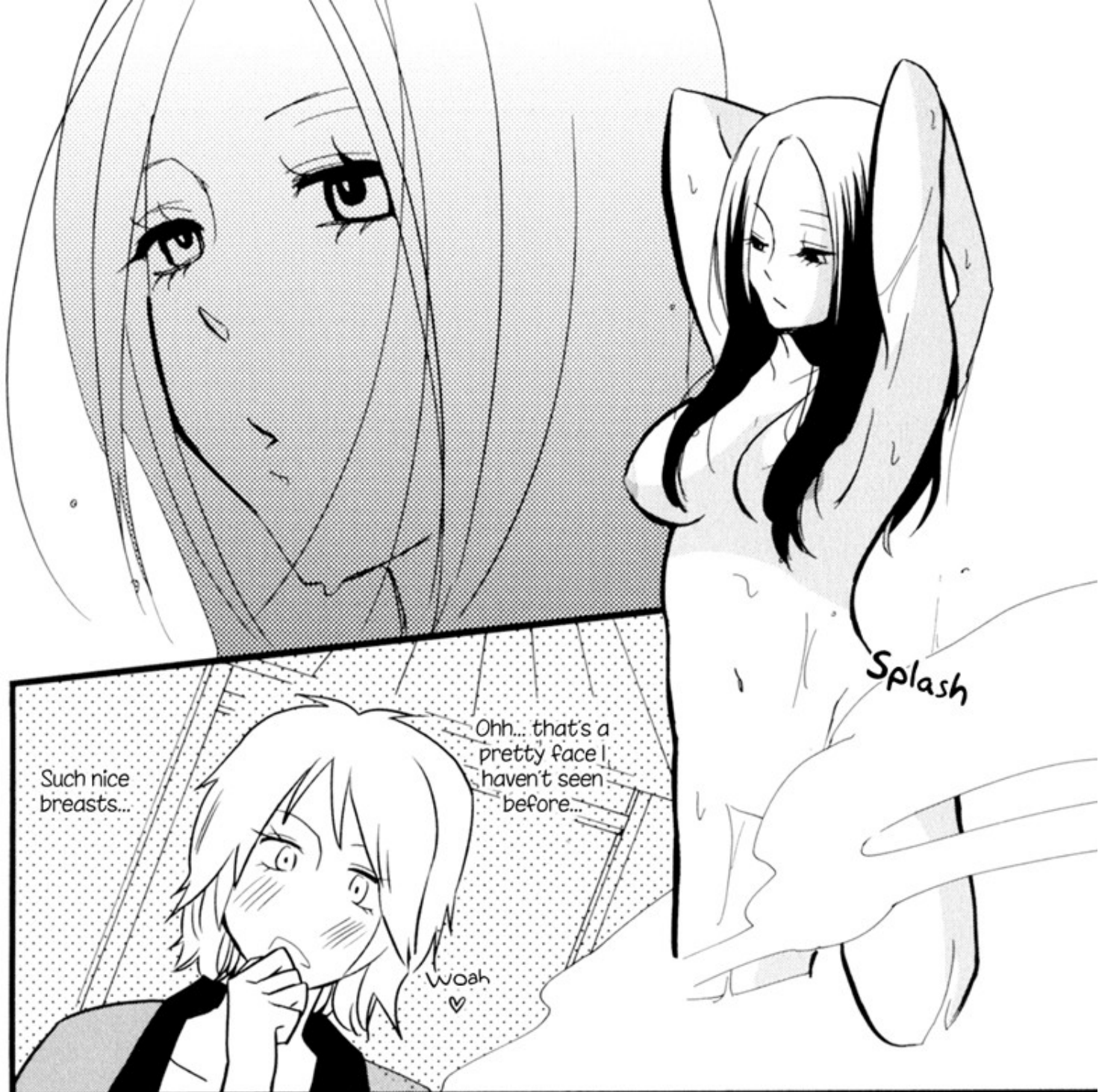



YES?

OH, HEY, MISS!

Towels for Rent

Well, that was some lovely eye candy!



OH? IS IT ALL RIGHT?

It's a free service. It's really good!

WOULD YOU LIKE SOME MILK?

Really, on the house.

FOR SHOWING ME SOMETHING NICE.



YOU'RE NOT FROM HERE, ARE YOU?

ARE YOU BY YOURSELF TODAY?



THANKS, I'LL TAKE ONE THEN.



AS A STRIPPER.

YES, I CAME TO WORK



Wha...

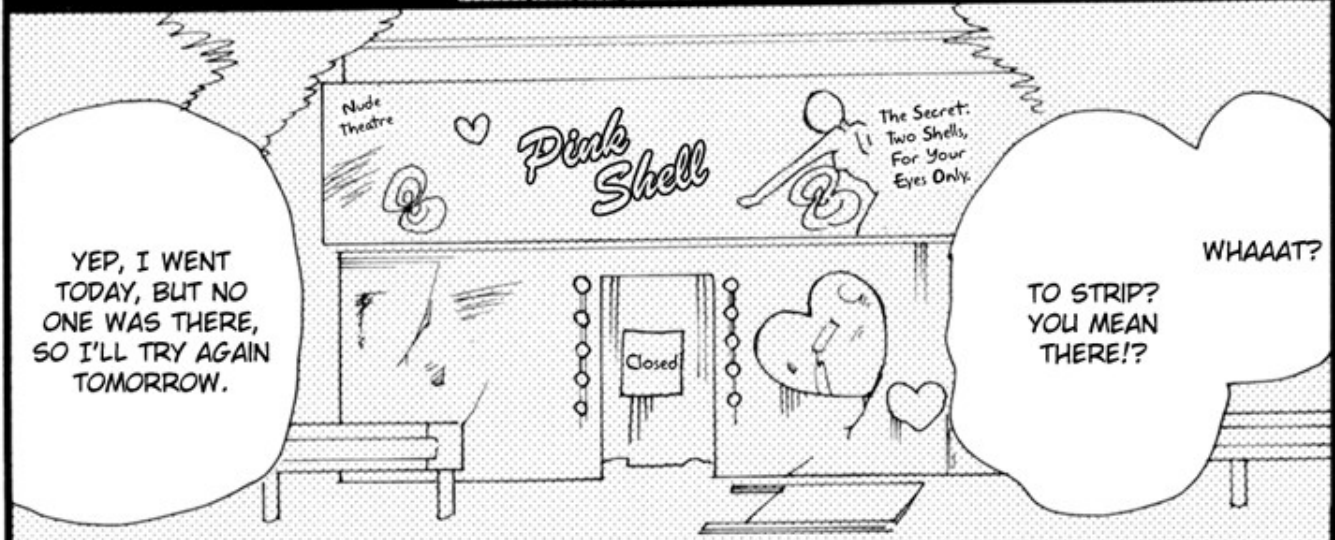

YEP, I WENT TODAY, BUT NO ONE WAS THERE, SO I'LL TRY AGAIN TOMORROW.

WHAAAT?  
TO STRIP? YOU MEAN THERE!?

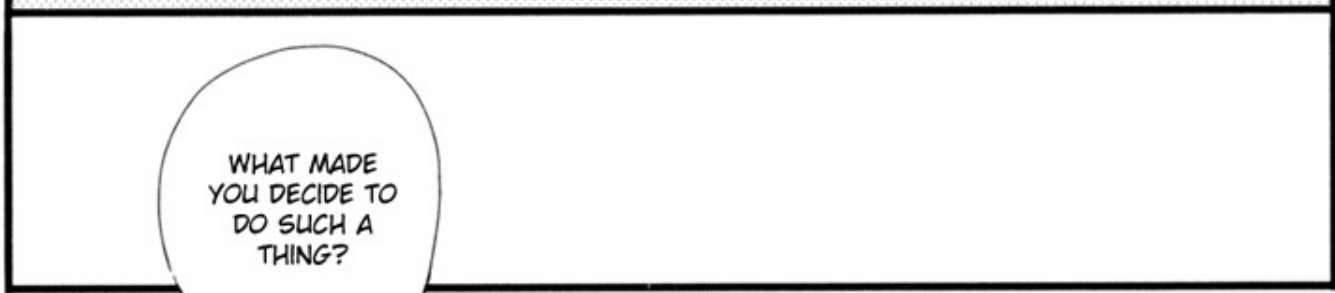

WHAT MADE YOU DECIDE TO DO SUCH A THING?



IF ONLY ALL PEOPLE WERE NICE LIKE YOU ARE.

I GUESS I GOT TIRED OF ALL THE OFFICE POLITICS IN MY LAST WORKPLACE.

HMMM...



I THINK I JUST WANT TO ONLY BE MY 'PHYSICAL SELF'.

HOW SHOULD I PUT IT...



SO, WHERE ARE YOU STAYING TONIGHT?

HUH. SOUNDS LIKE YOU'VE SEEN SOME TOUGH TIMES.

Though I don't really get it...

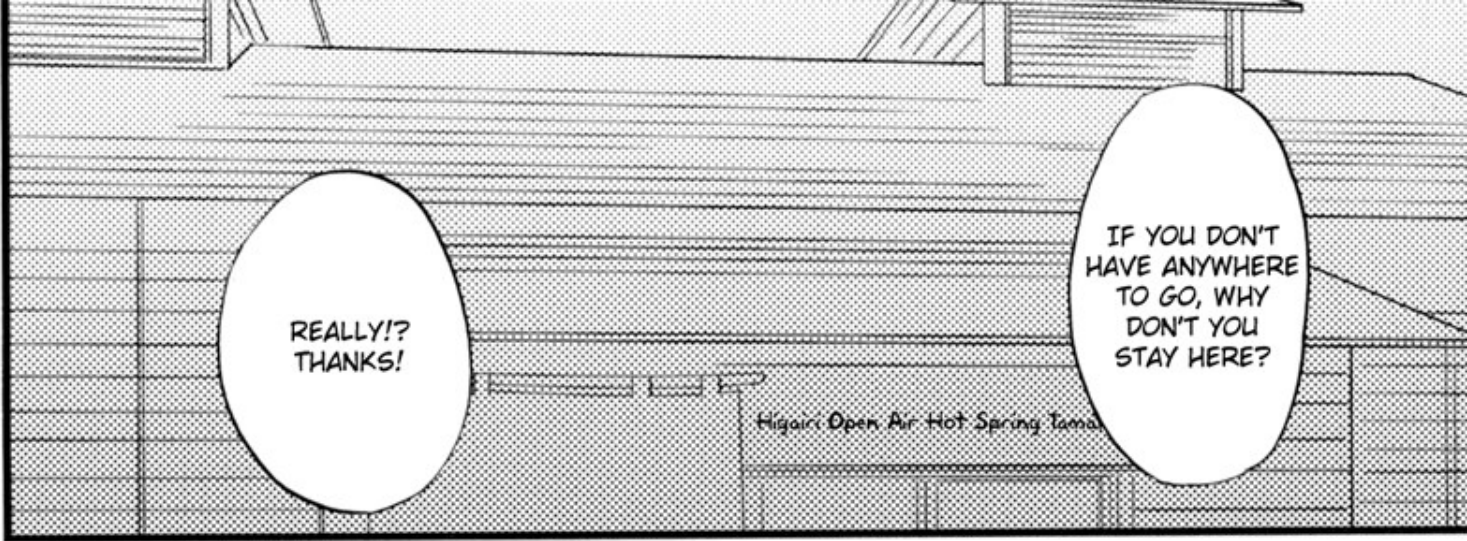

REALLY!?  
THANKS!

IF YOU DON'T  
HAVE ANYWHERE  
TO GO, WHY  
DON'T YOU  
STAY HERE?

Higairi Open Air Hot Spring Tama

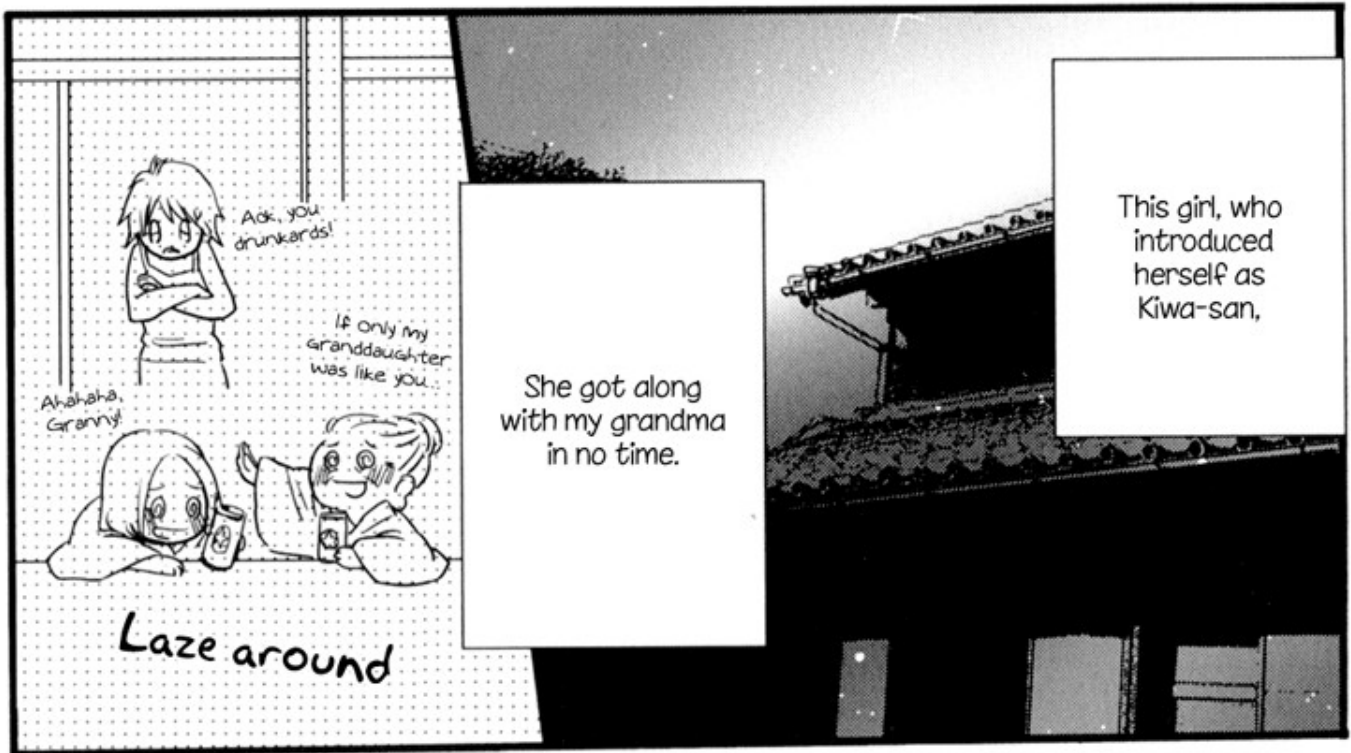

Ack, you  
drunkards!

Aha-ha,  
Granny!

If only my  
granddaughter  
was like you.

Laze around

She got along  
with my grandma  
in no time.

This girl, who  
introduced  
herself as  
Kiwa-san,



THUD

Huff  
Huff

OKAY, COME  
ALONG NOW,  
KIWA-SAN.  
IT'S OFF TO  
BED NOW

Drag

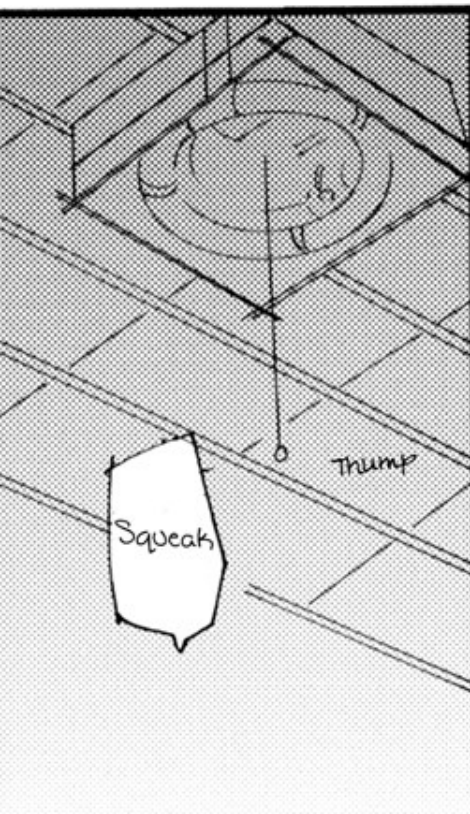
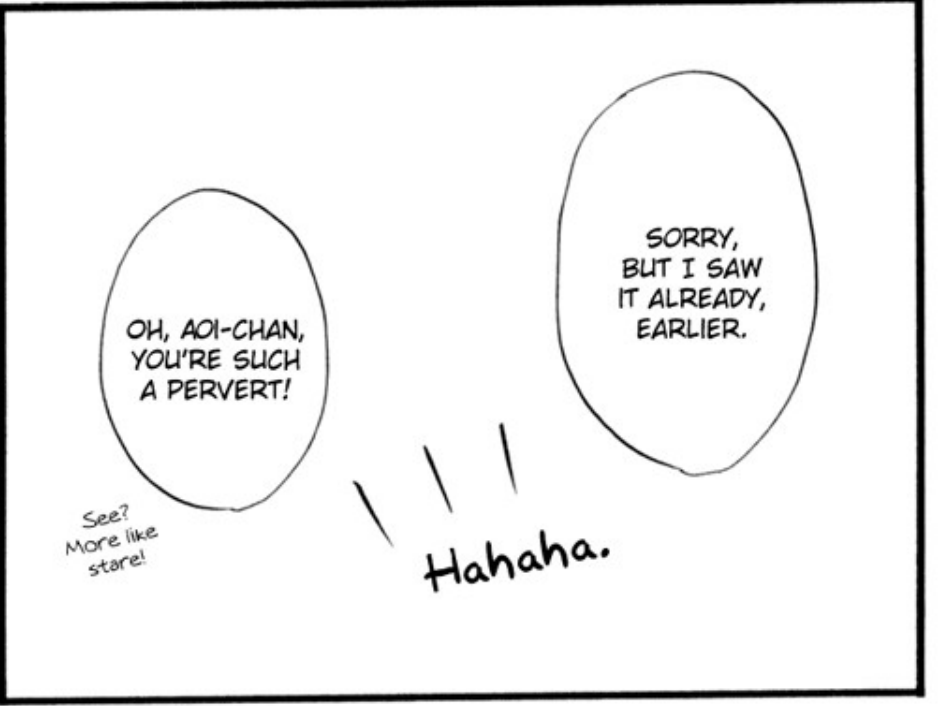



I had a feeling  
that Kiwa-san...

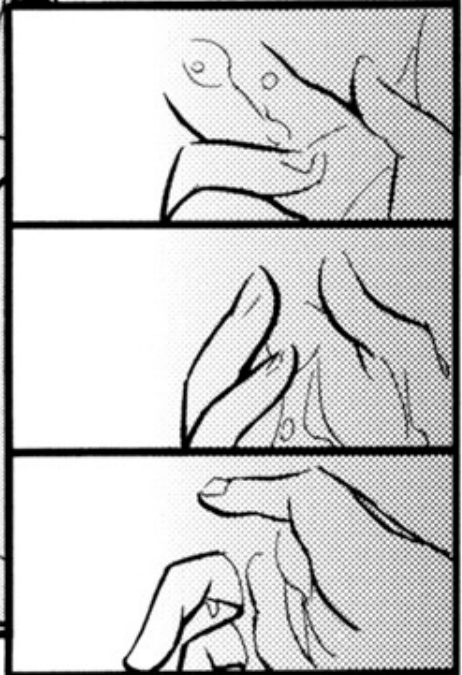
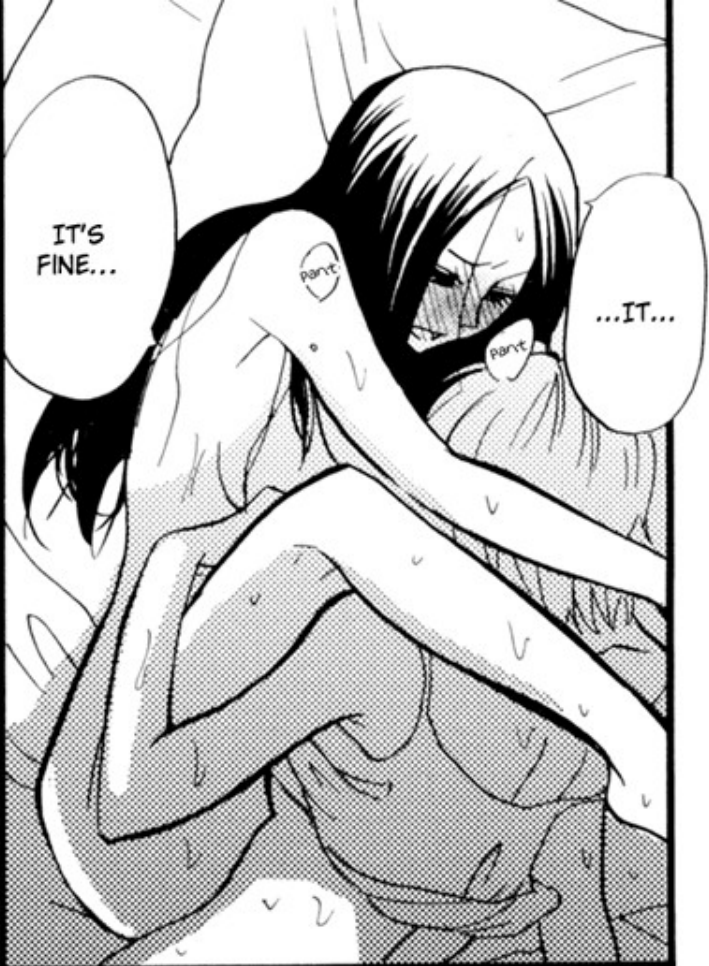

...might be lonely.

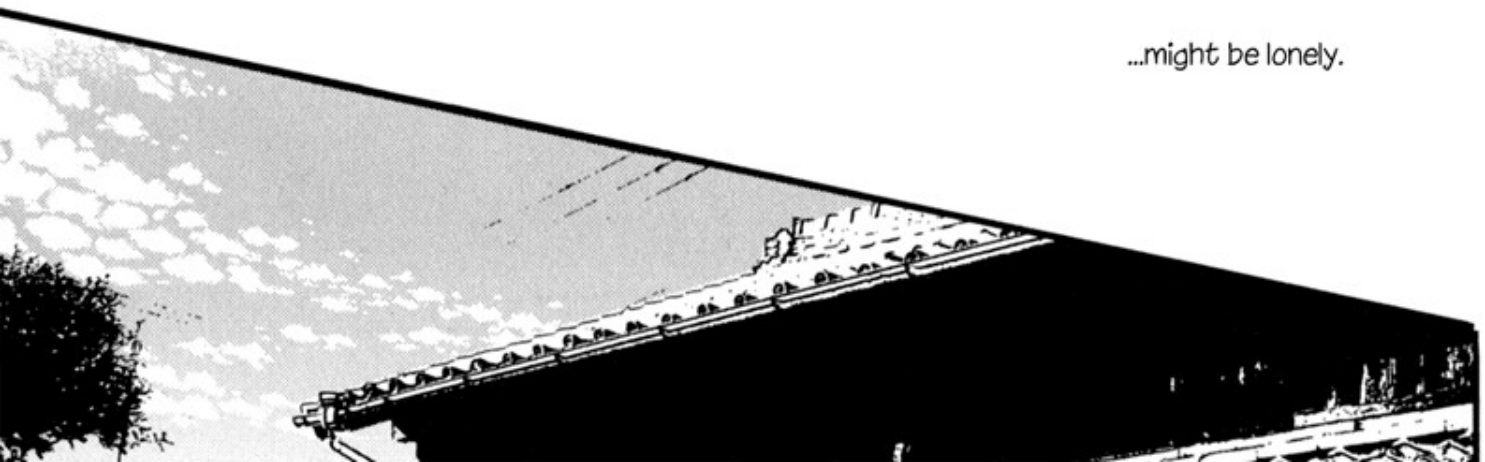

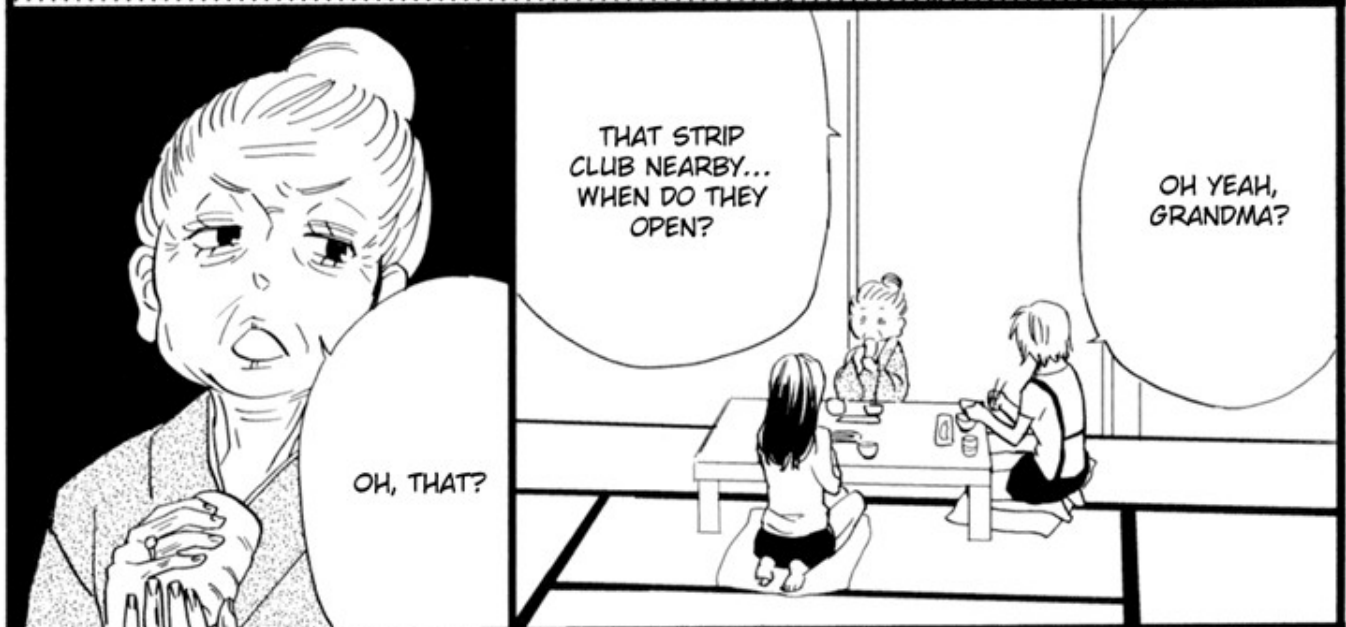
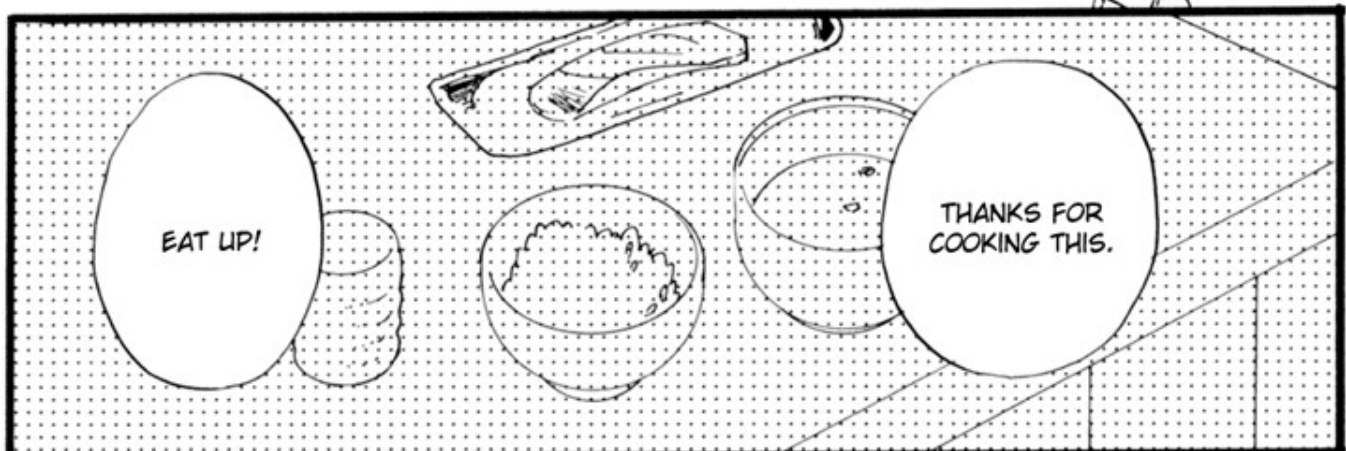
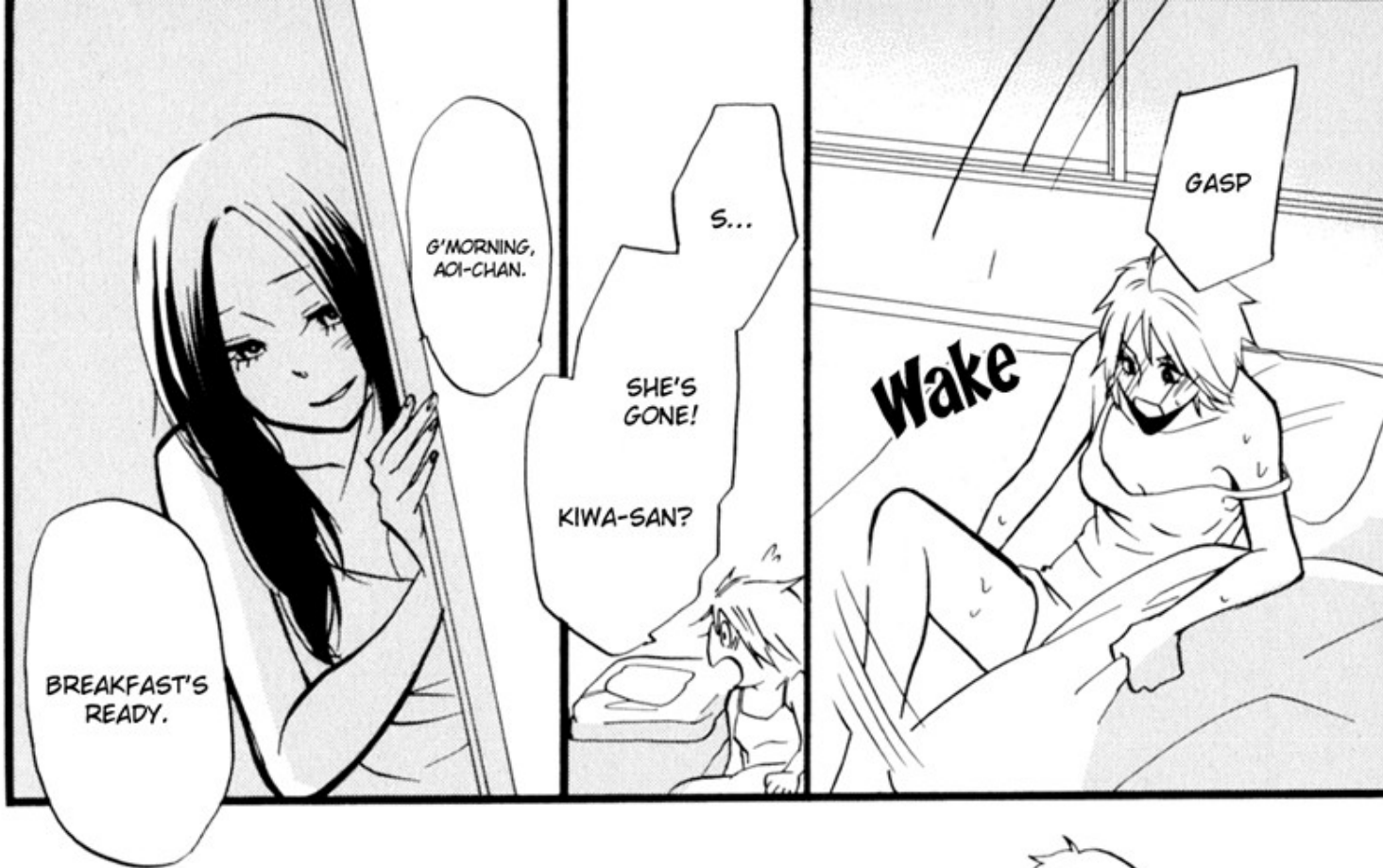

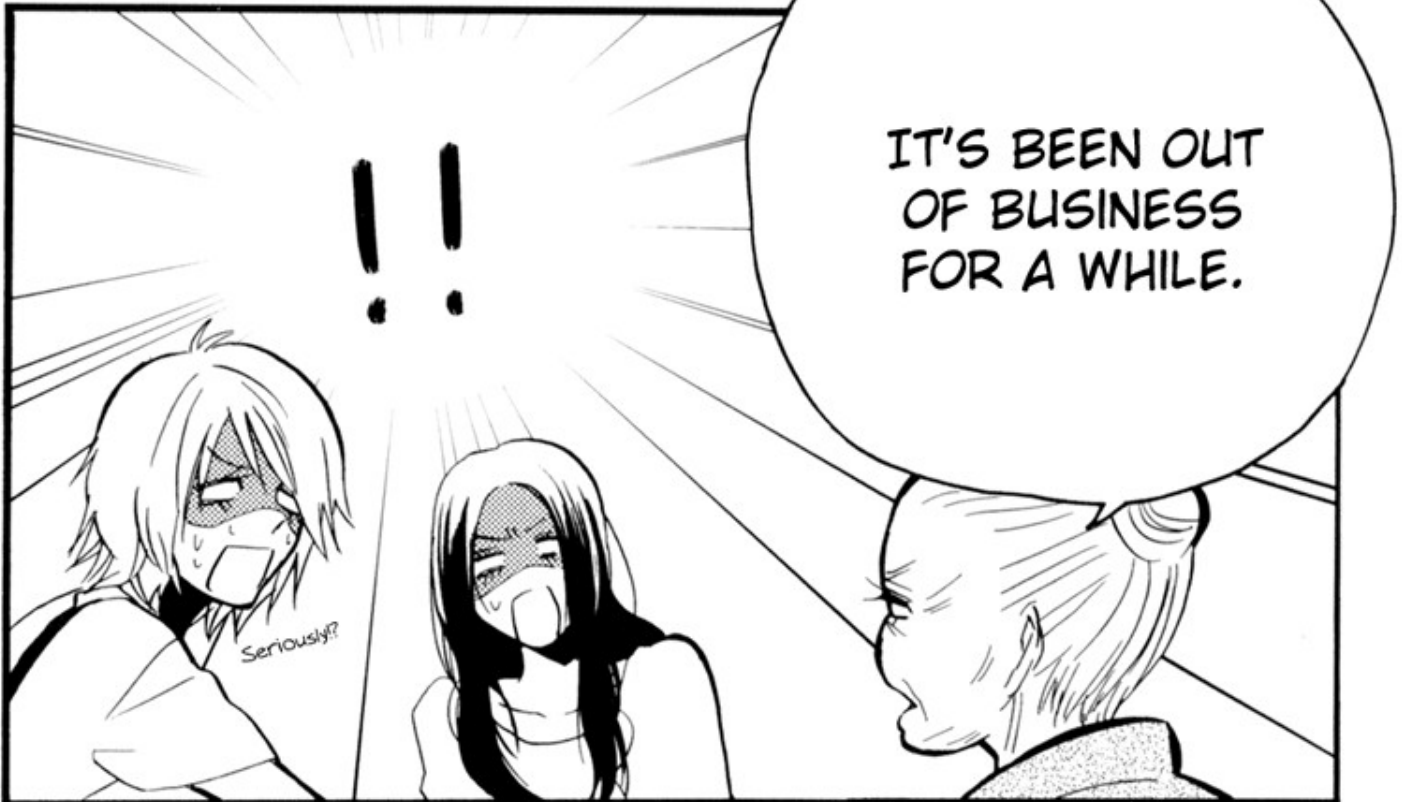

Seriously?!

IT'S BEEN OUT OF BUSINESS FOR A WHILE.



I SEE.

...

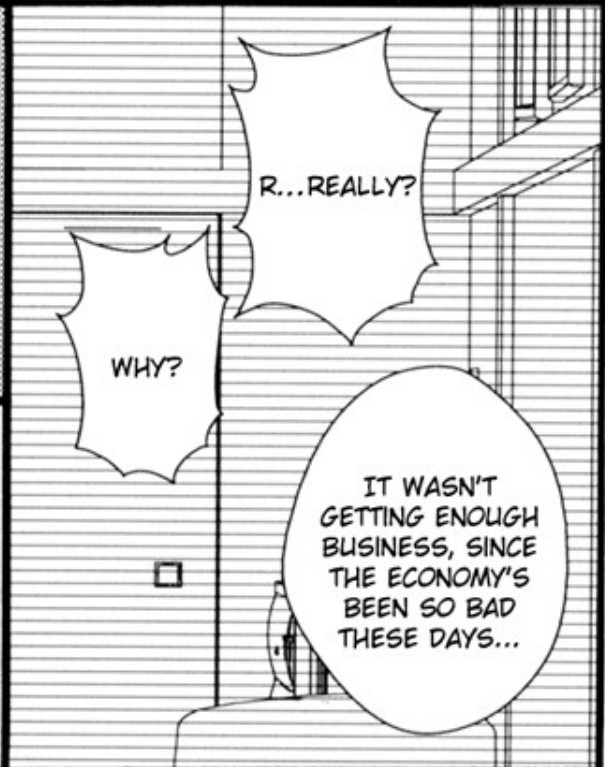

R...REALLY?

WHY?

IT WASN'T GETTING ENOUGH BUSINESS, SINCE THE ECONOMY'S BEEN SO BAD THESE DAYS...

Kiwa-san is so disappointed...



I really want to give her a job, but...

I wish there was something I could do for her...

We really can't afford to right now...

OKAY THEN,

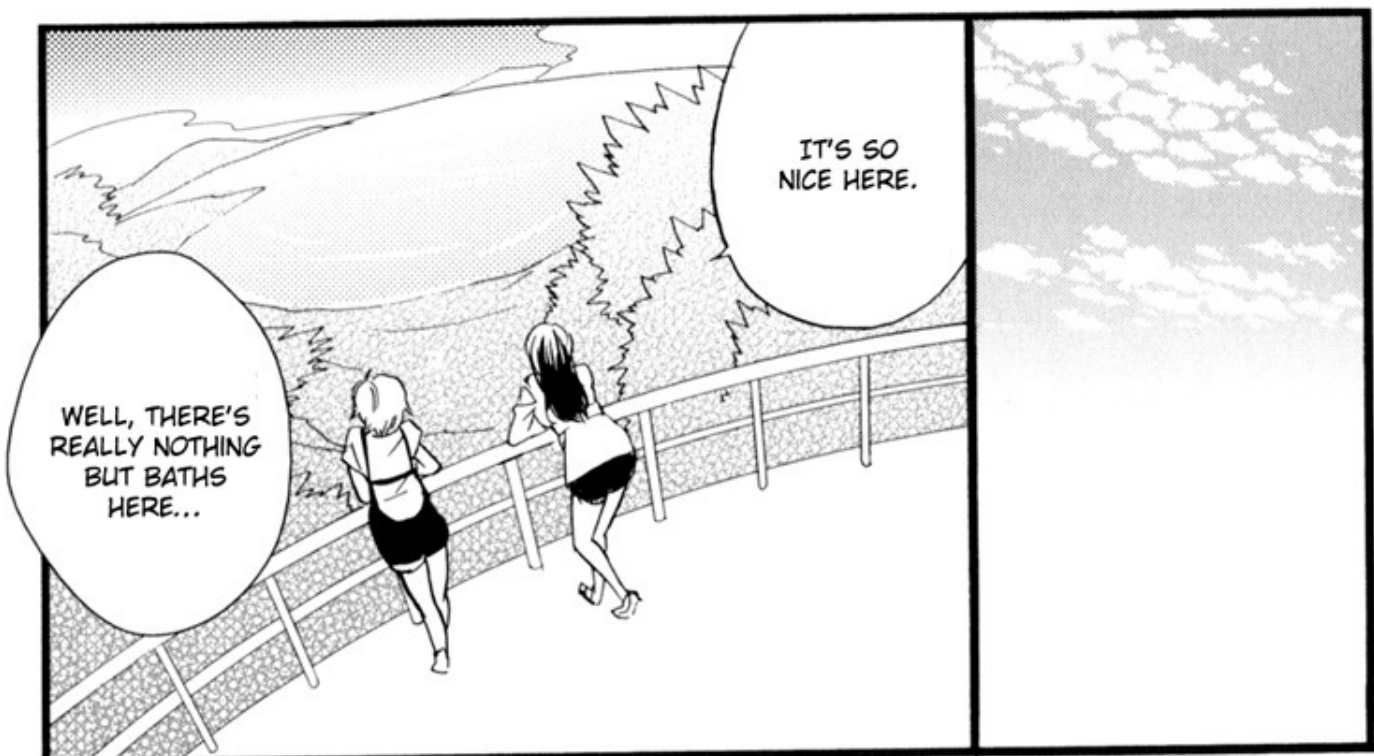



THANKS TO YOU,  
I FEEL LIKE I  
SHOULDN'T GIVE  
UP ON PEOPLE  
JUST YET.

...I...

I'M SORRY,  
AFTER ALL  
YOU'VE DONE  
FOR ME...

IT'S FINE,  
IT'S FINE.



Brrrrrr



HELLO?  
WHAT, GRANDMA?

Beep



HUH?

AOI! KIWA-SAN!  
COME BACK  
QUICKLY!





CAT?

Clutter

WHERE'S THE CAT?

Higairi Open Air Hot Spring Tamaki

Clutter

SO THIS IS THE HOT SPRING CAT!

Chatter

Chatter



That's our place?

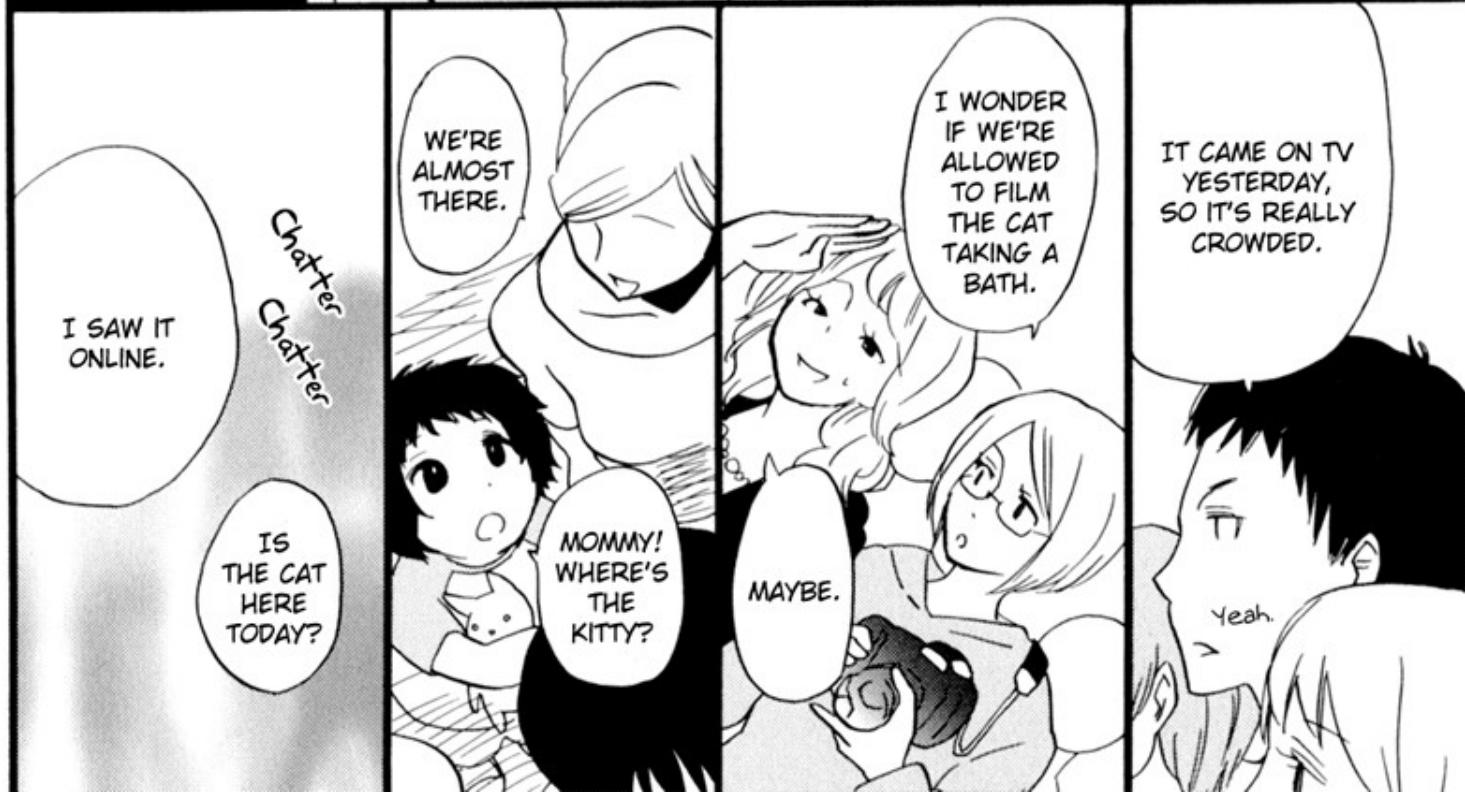

I SAW IT ONLINE.

Chatter  
Chatter

IS THE CAT HERE TODAY?

WE'RE ALMOST THERE.

MOMMY! WHERE'S THE KITTY?

MAYBE.

I WONDER IF WE'RE ALLOWED TO FILM THE CAT TAKING A BATH.

IT CAME ON TV YESTERDAY, SO IT'S REALLY CROWDED.

Yeah.

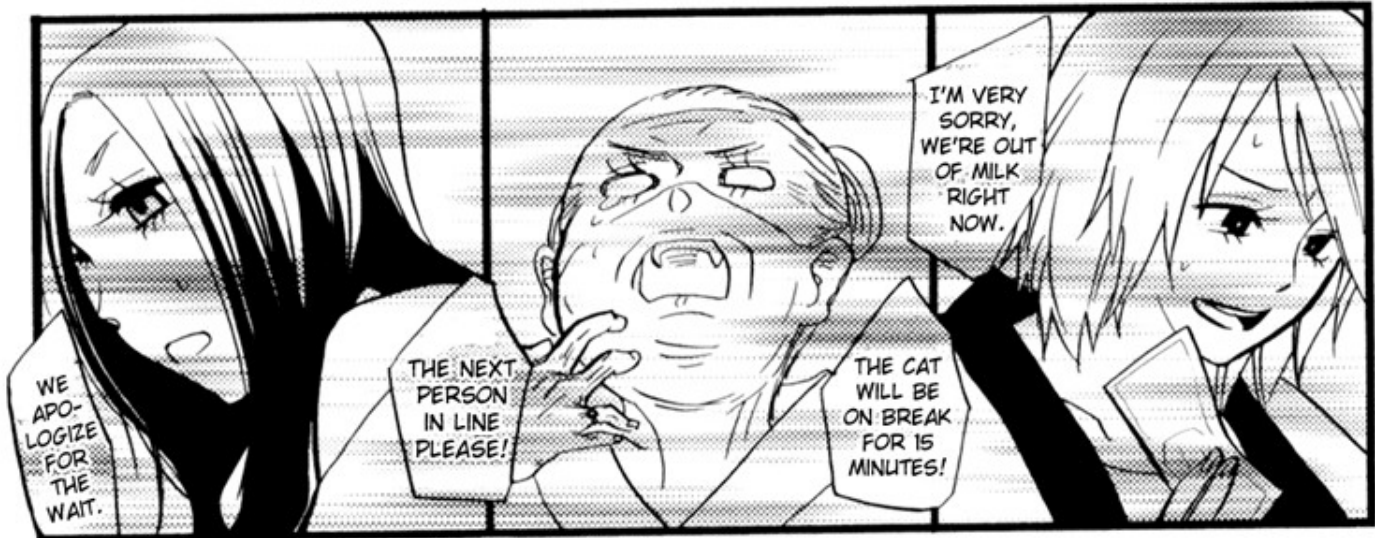

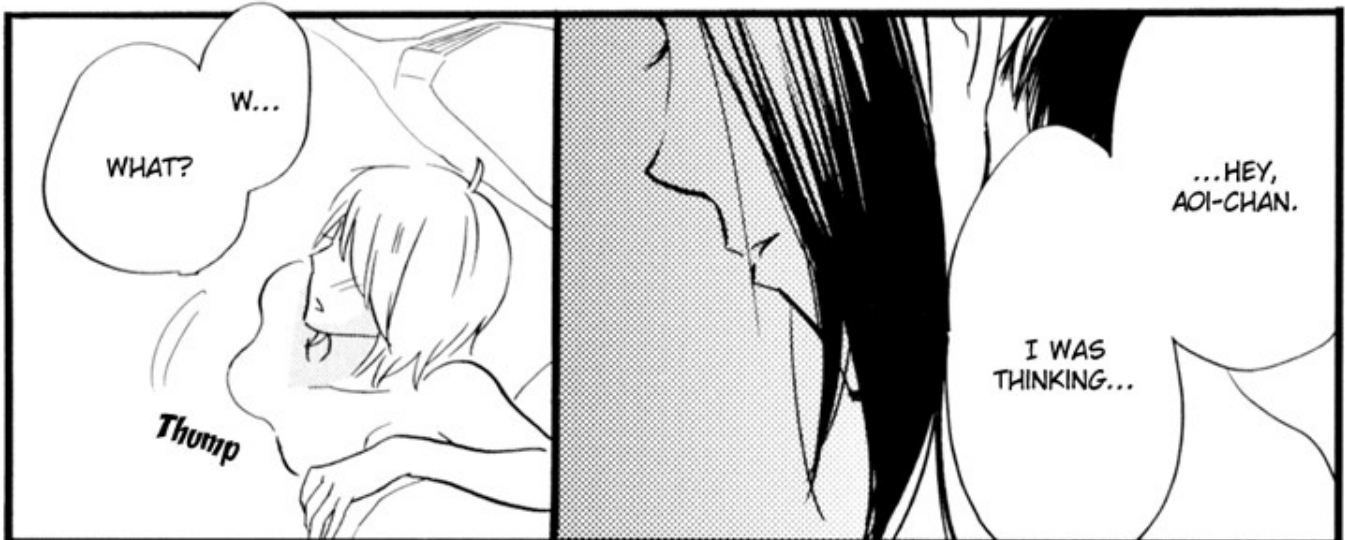
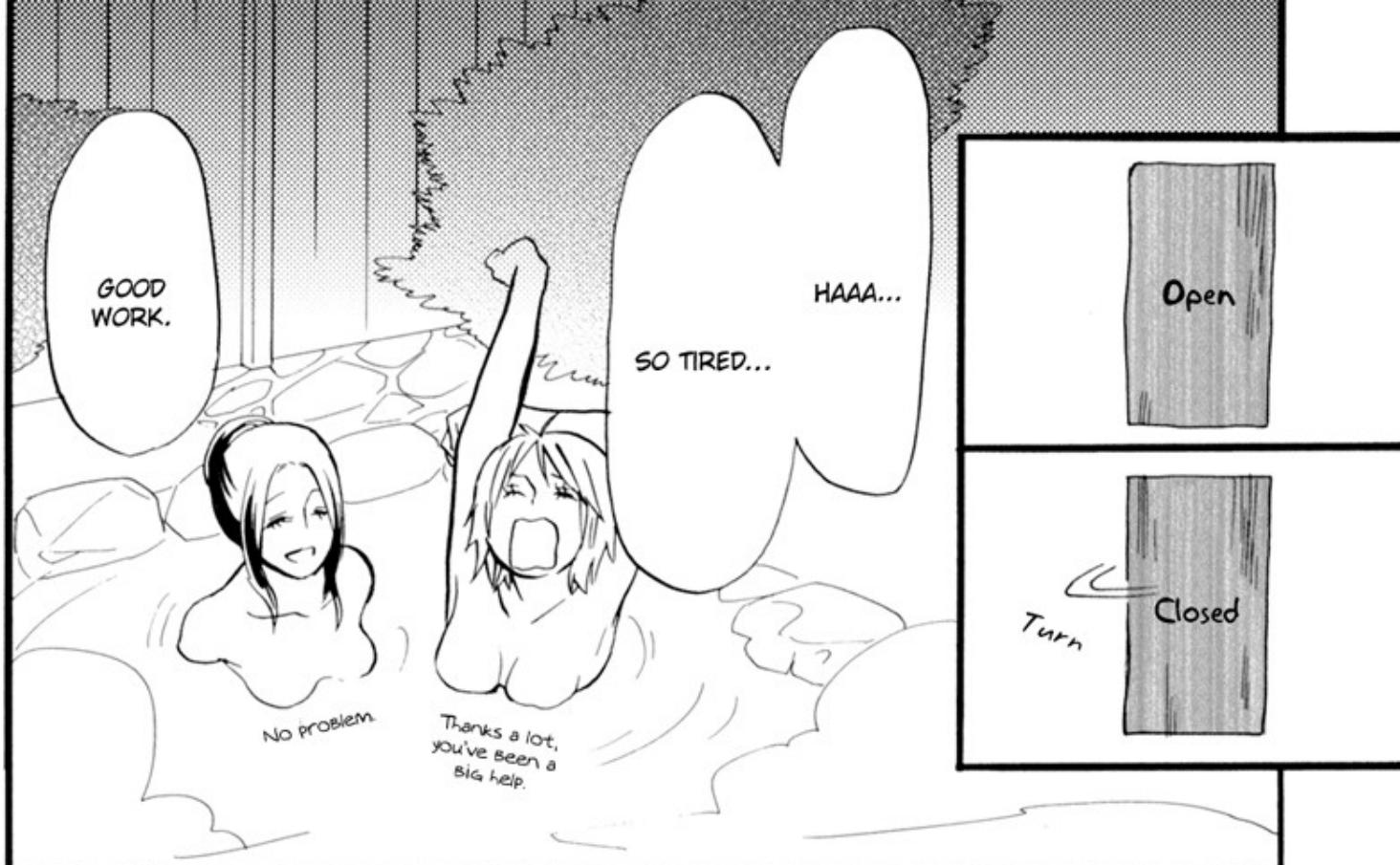





SHOUT

That?!

Splash

Rebuilding  
the strip  
club!!



I'LL HELP YOU  
WITH EVERYTHING  
I CAN, AOI-CHAN!

I'll live  
here!!



Fwar

WE CAN  
DO IT!!

Okay!  
Ready?!

W... WE  
CAN DO  
IT...

Oh  
well...

The background features a faint, light-colored illustration of several anime-style characters. In the foreground, there is a more prominent illustration of two characters: one with long brown hair and green eyes looking upwards, and another with short brown hair and red eyes looking forward with a surprised expression. The text is overlaid on the left side of the image.

Yukemuri Sanctuary - Chapter 02

Raws: Audio Erotica

Translator : Hitsujī-san

Proofreader : Babelglyph

Editor: Kite

Quality Checker: Audio Erotica

[www.tranquilspring.com](http://www.tranquilspring.com)

[www.Payapaya-Scans.com](http://www.Payapaya-Scans.com)

Visit Payapaya's IRC channel at:

#Payapaya @ rizon.net



HEY GUYS!  
DO YOU  
LIKE ME!?

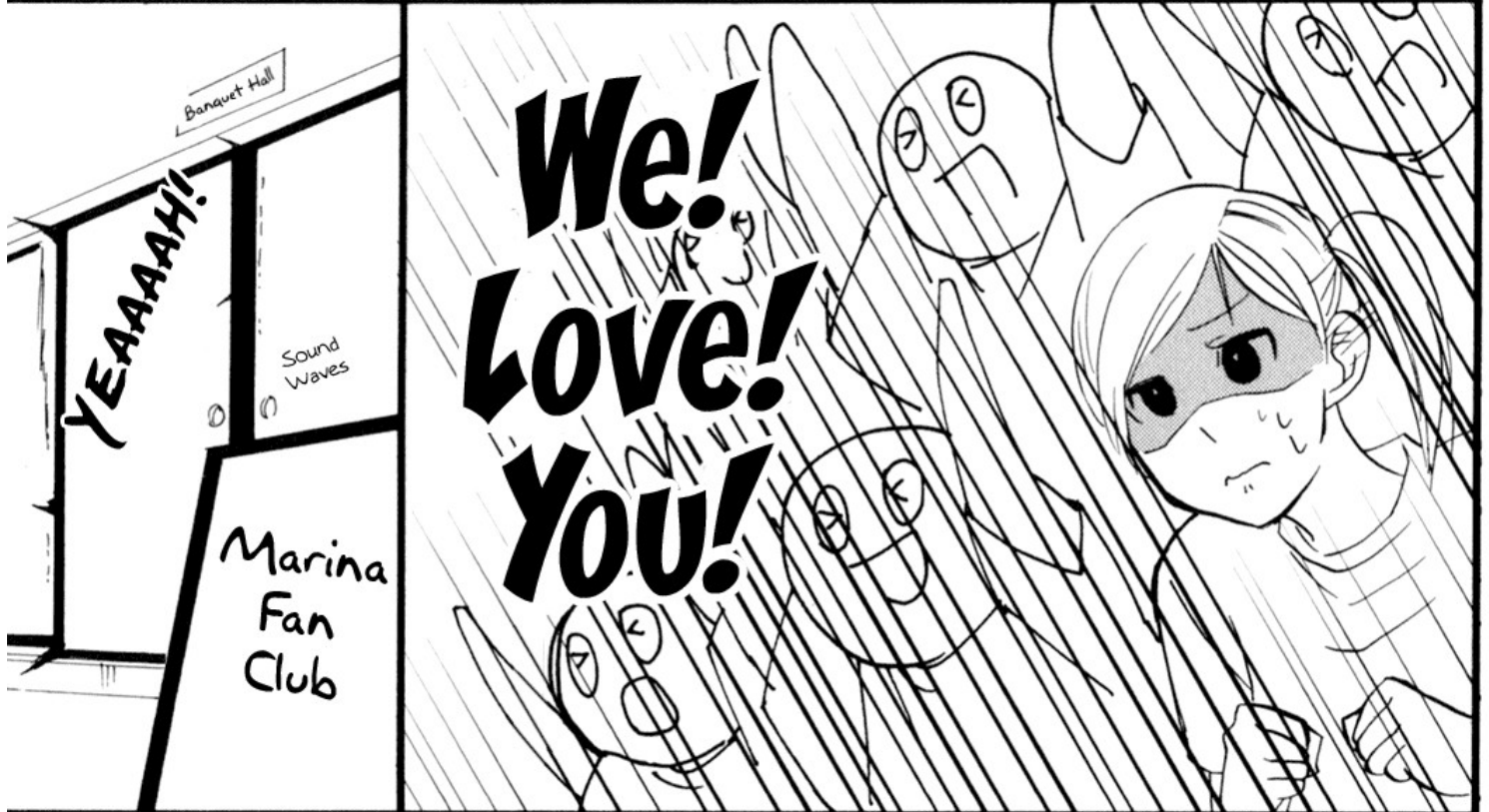

YEAAAAHI!

Banquet Hall

Sound Waves

Marina Fan Club

We!  
Love!  
You!

SHE'S  
PUTTING HER  
LIFE ON THE  
LINE.

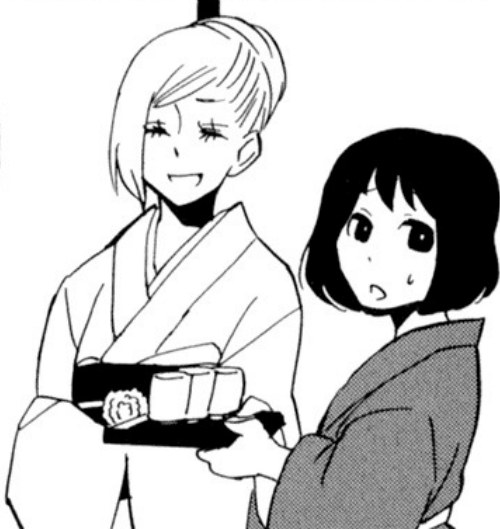

TODAY'S  
CUSTOMER  
IS ONE OF  
A KIND.

Kyaaa!  
Waaahs!  
Marinaaaa!!  
Thanks!



☪ THIRD NIGHT ☪

WORSHIPPING THE YUDEMURI IDOL



# Marina's Heart-Warming Fan Club Tour: Oniyuri

You're all in such high spirits!



I'm currently on a fan club trip for Marina-chan, an idol.

My name is Kumi.



Honestly... I think I'm in love.

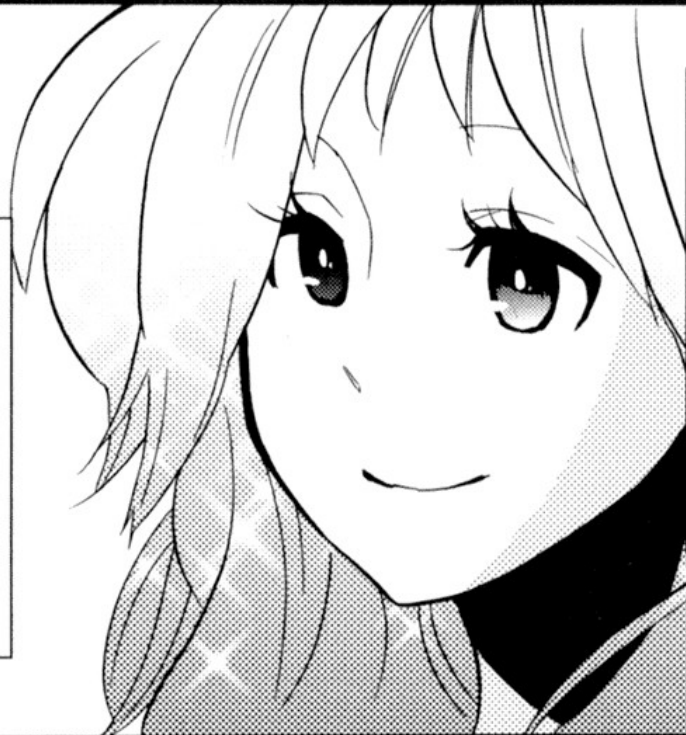

Marina-chan is gorgeous, an awesome singer with such a cute voice!!



Swig



Gulp



Swig

Makes me want to drink my sorrows away!!

Swig



But I know it's a hopeless, one-sided crush, and nothing'll ever happen with it...

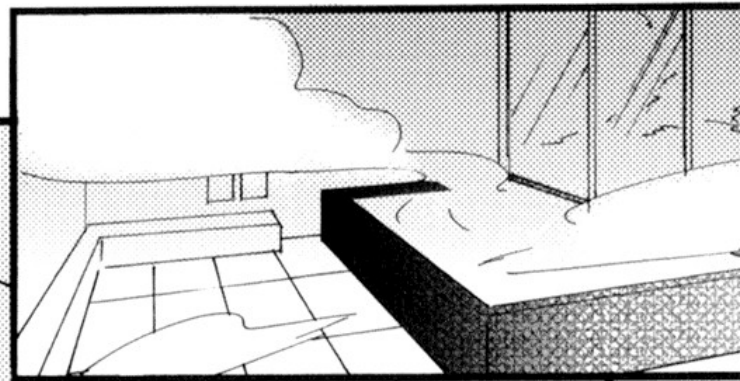

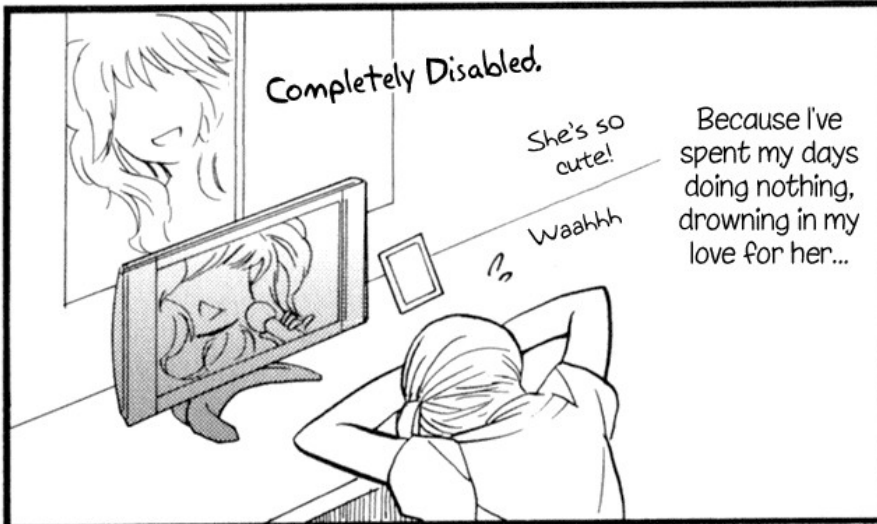

Completely Disabled.

She's so cute!

Waahhh

Because I've spent my days doing nothing, drowning in my love for her...



She's a celebrity...

There's no way my feelings could reach her.

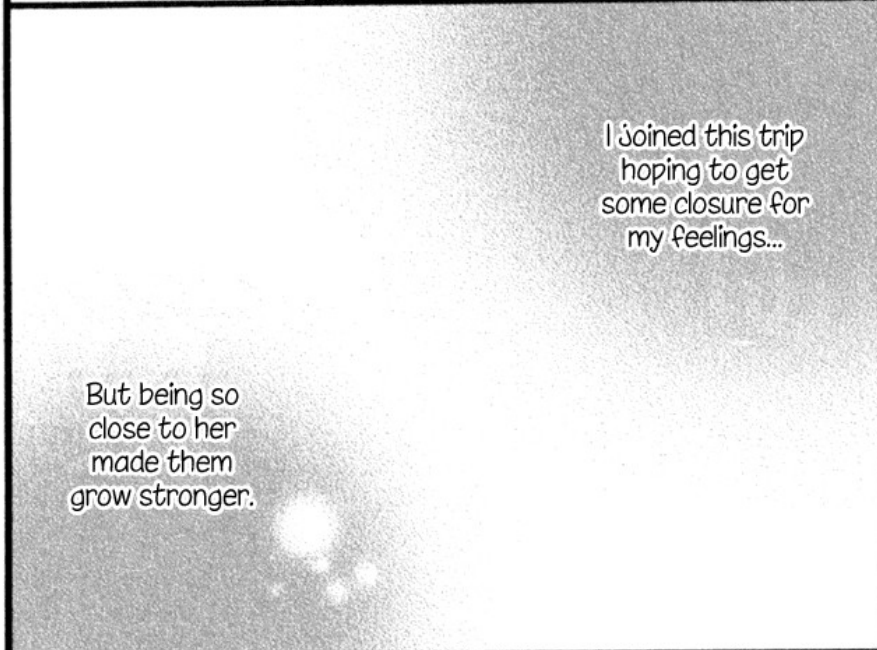

I joined this trip hoping to get some closure for my feelings...

But being so close to her made them grow stronger.



YES!?

BADUMPI!

Startled

HEY, YOU THERE.



Sighhh...

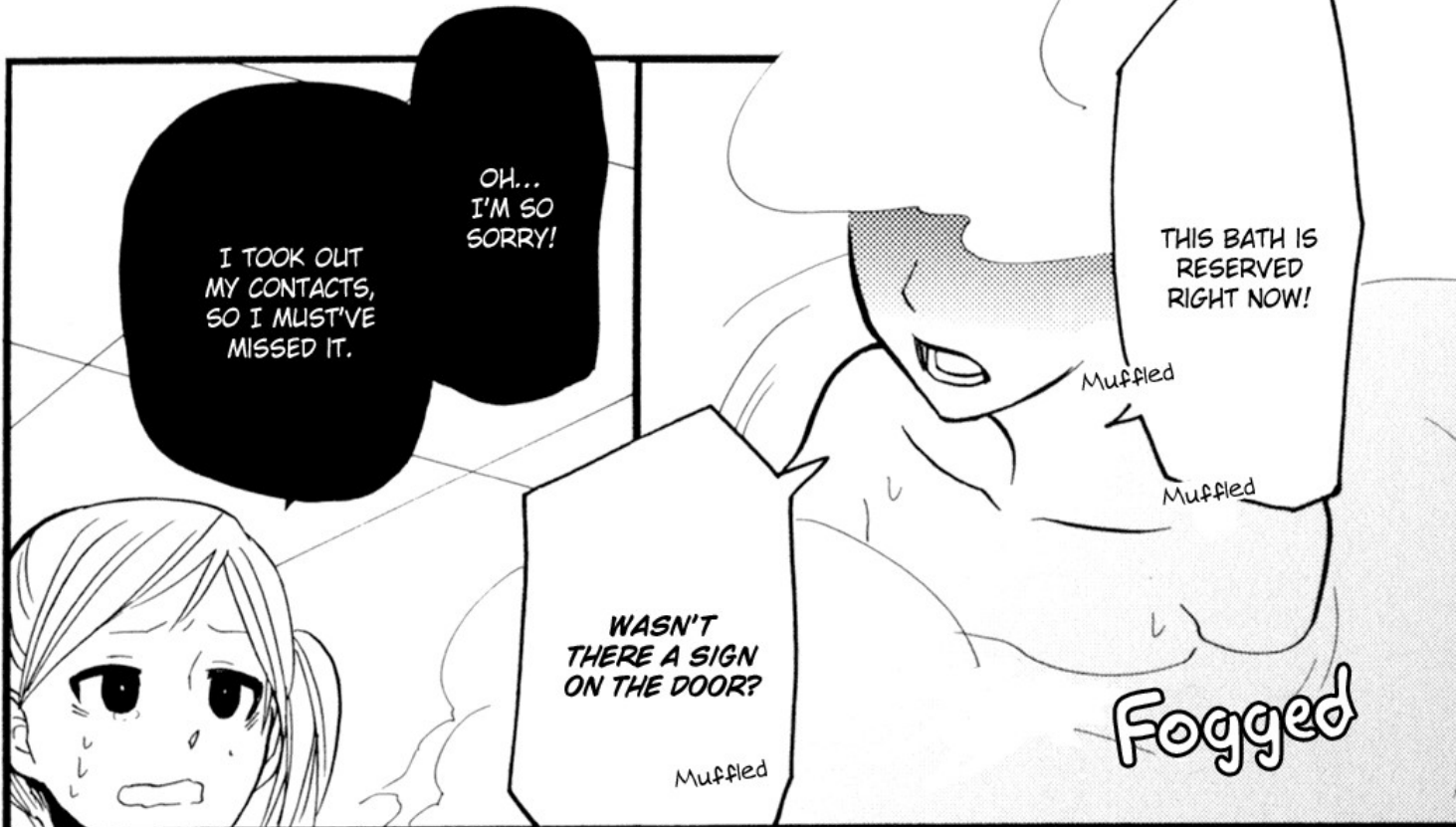

I TOOK OUT MY CONTACTS, SO I MUST'VE MISSED IT.

OH... I'M SO SORRY!



WASN'T THERE A SIGN ON THE DOOR?

Muffled

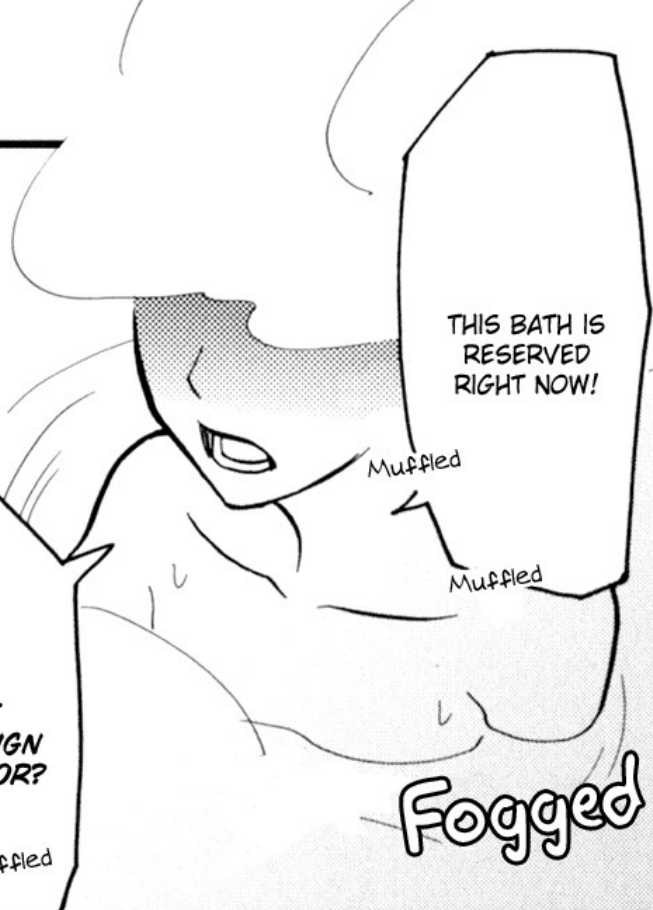

Fogged



I... I'M SORRY...

What's wrong?  
Are you not feeling well?

WELL... IT'S FINE, BUT DON'T JUST COME IN HERE LOOKING ALL GLOOMY AND SIGHING.

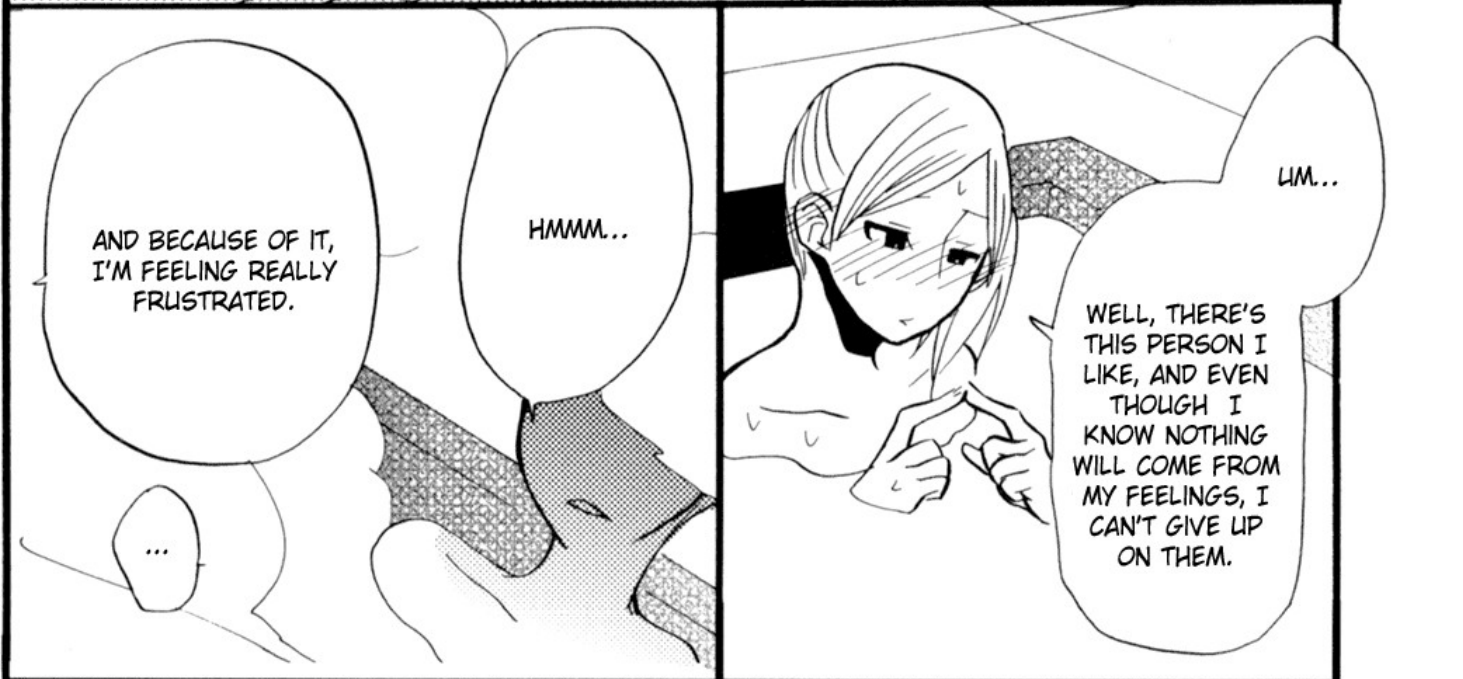

AND BECAUSE OF IT, I'M FEELING REALLY FRUSTRATED.

...

HMMM...



UM...

WELL, THERE'S THIS PERSON I LIKE, AND EVEN THOUGH I KNOW NOTHING WILL COME FROM MY FEELINGS, I CAN'T GIVE UP ON THEM.



LIKE THIS?

UM...  
OKAY.

TURN  
AROUND, AND  
CLOSE YOUR  
EYES.

THEN I'LL  
TEACH YOU  
SOMETHING  
NICE.



Swish



Tighten

WHA...

I can't see anything...





YOU JUST HAVE TO GET RID OF YOUR FRUSTRATION.

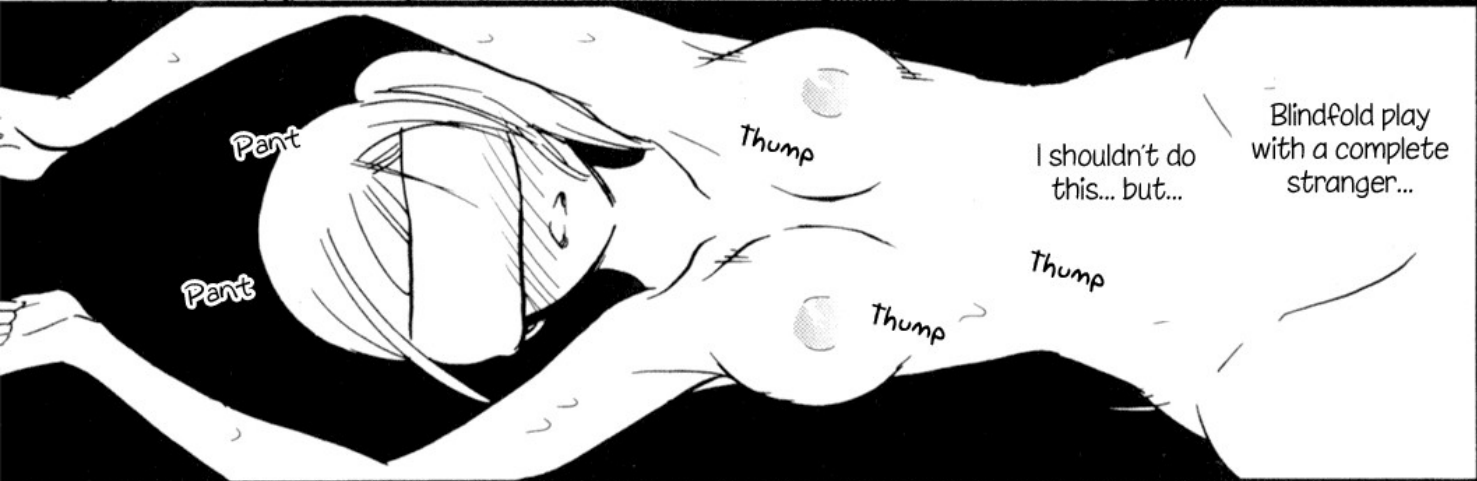

I shouldn't do this... but...  
Blindfold play with a complete stranger...



YOU KNOW...  
YOU SHOULDN'T GIVE UP ON WHAT YOU WANT SO EASILY.

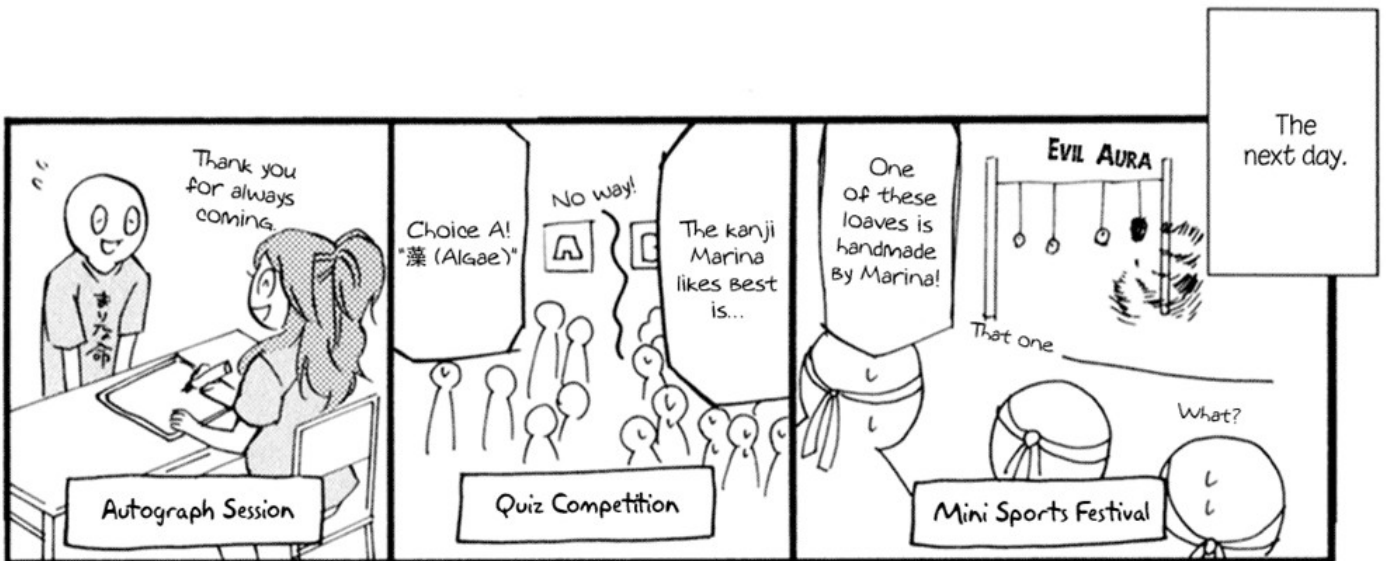
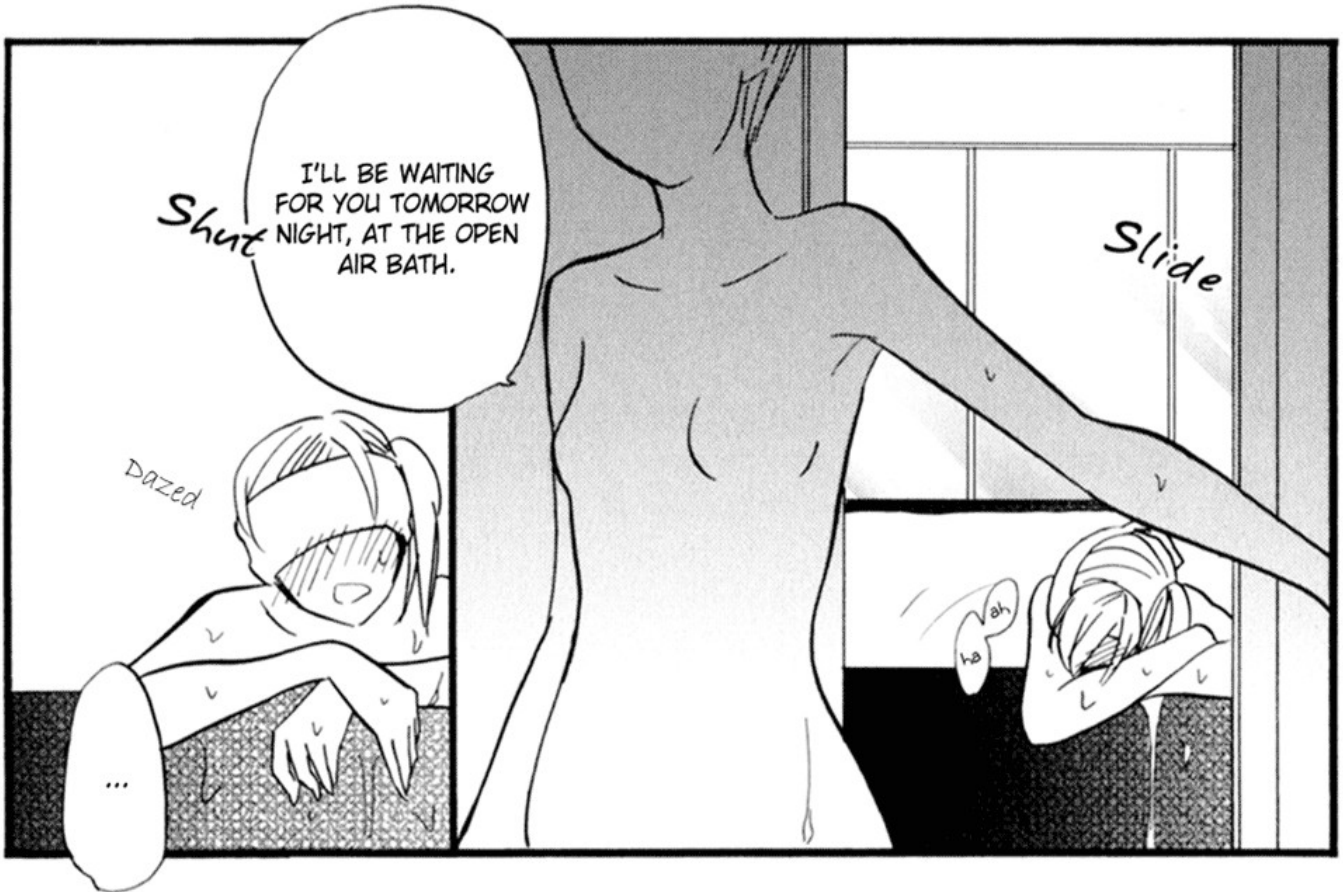

The next day.

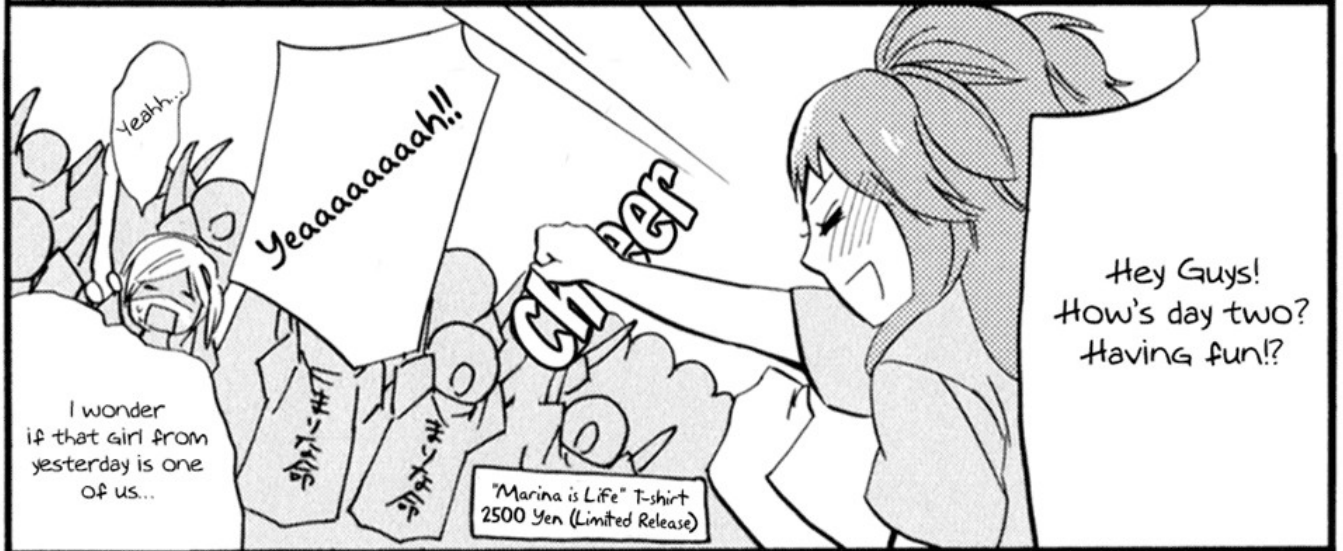

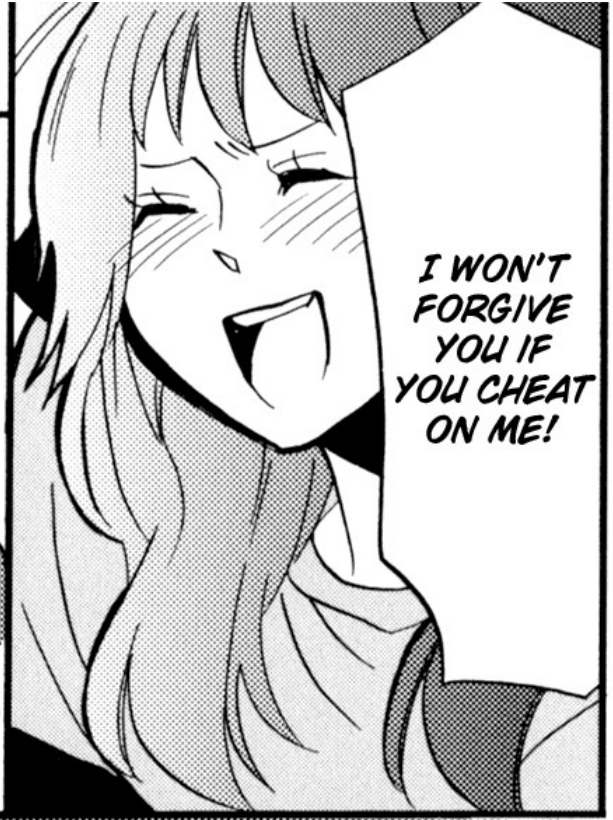

Is the girl from yesterday here...?

With my contacts on, I should be able to see her today...





Why is  
Marina-chan here?



HEY!?

startled



Hm?

Sneak

I... I SHOULD  
LEAVE...

I'll get  
arrested...



That  
means...  
yesterday...

Ehh...

I WAS WAITING  
FOR YOU.



Waaahh!

BECAUSE... IT'S IMPOSSIBLE!

YOUR VOICE WAS DIFFERENT TOO...



NO...



YOU SERIOUSLY DIDN'T KNOW?



BUT... WHY SOMEONE LIKE ME?



MY "IDOL" VOICE IS MADE UP TO BE HIGH!

MY NATURAL VOICE IS LOWER.

Muffled

My friends back home call it a fraud, and claim that I inhale helium for it!



HUH?

WELL, THAT'S BECAUSE...



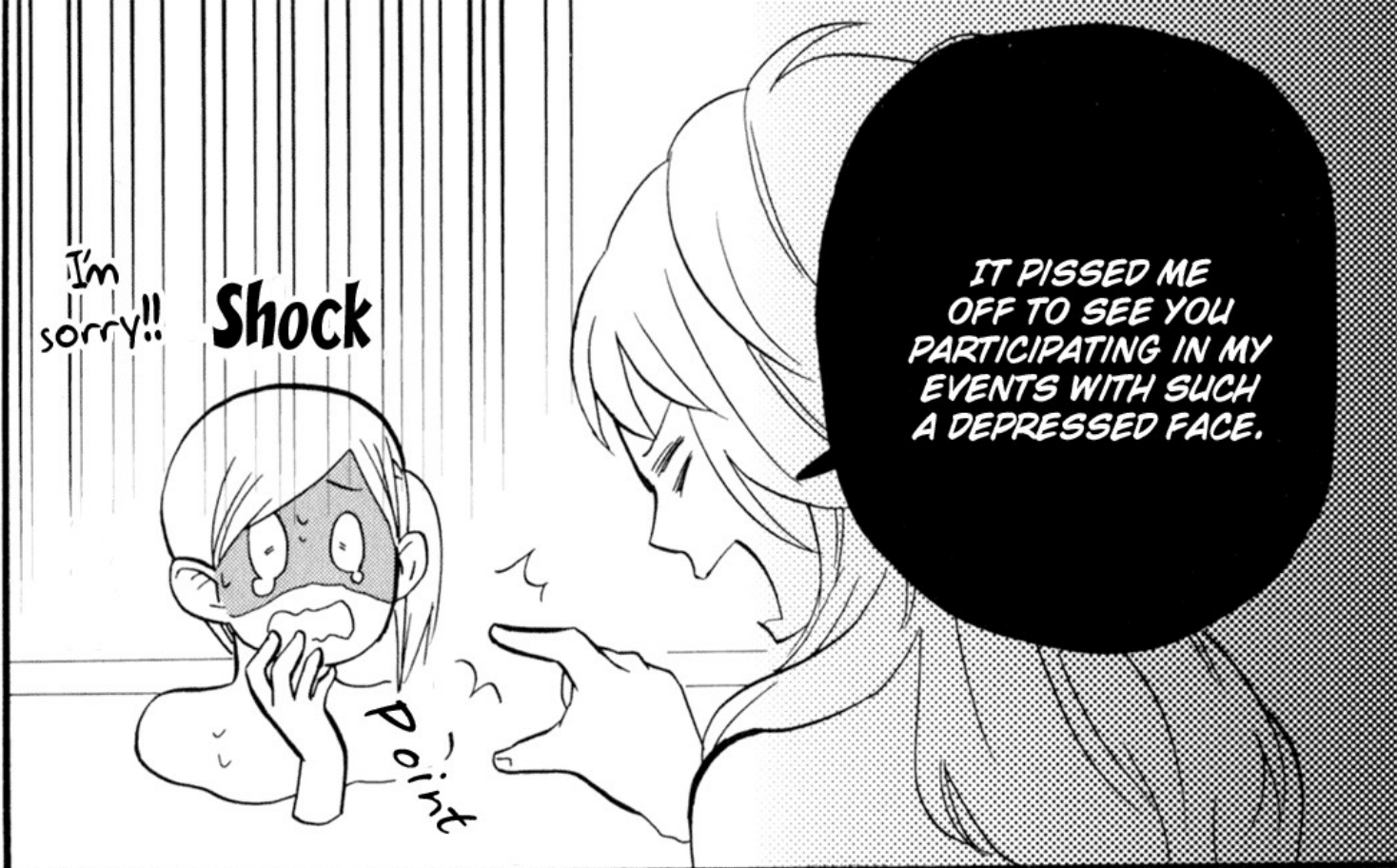

I'm sorry!!

**Shock**

Point

IT PISSED ME OFF TO SEE YOU PARTICIPATING IN MY EVENTS WITH SUCH A DEPRESSED FACE.



I'VE BEEN BUSY LATELY, AND HAVE BEEN BUILDING UP STRESS...

I GUESS I WAS FRUSTRATED TOO.

WELL, THAT'S NOT ALL...



CAN I HELP YOU GET RID OF SOME OF THOSE FRUSTRATIONS?

IF IT'S OKAY WITH YOU...

WELL THEN...



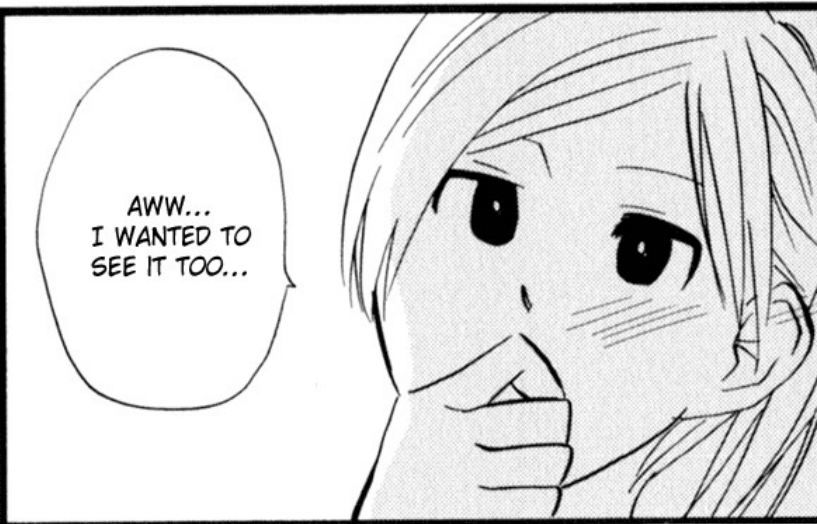
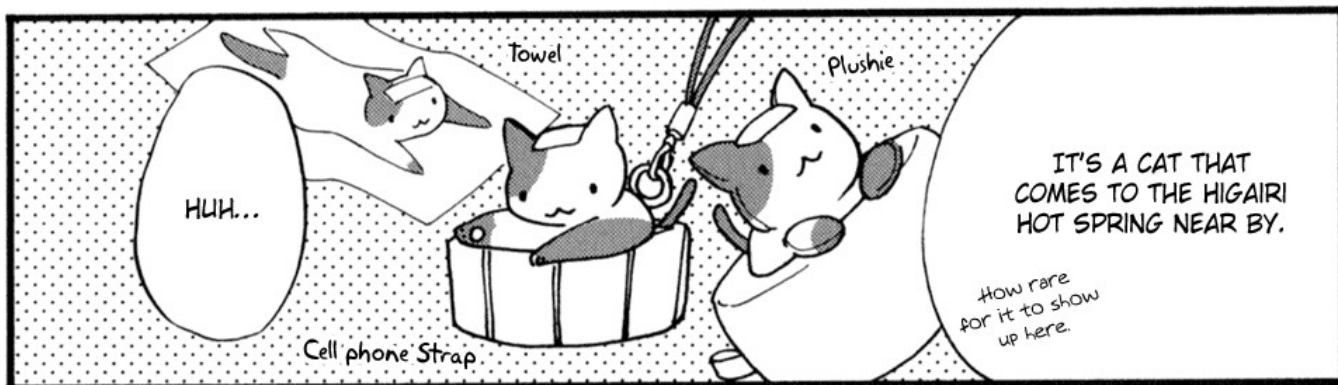

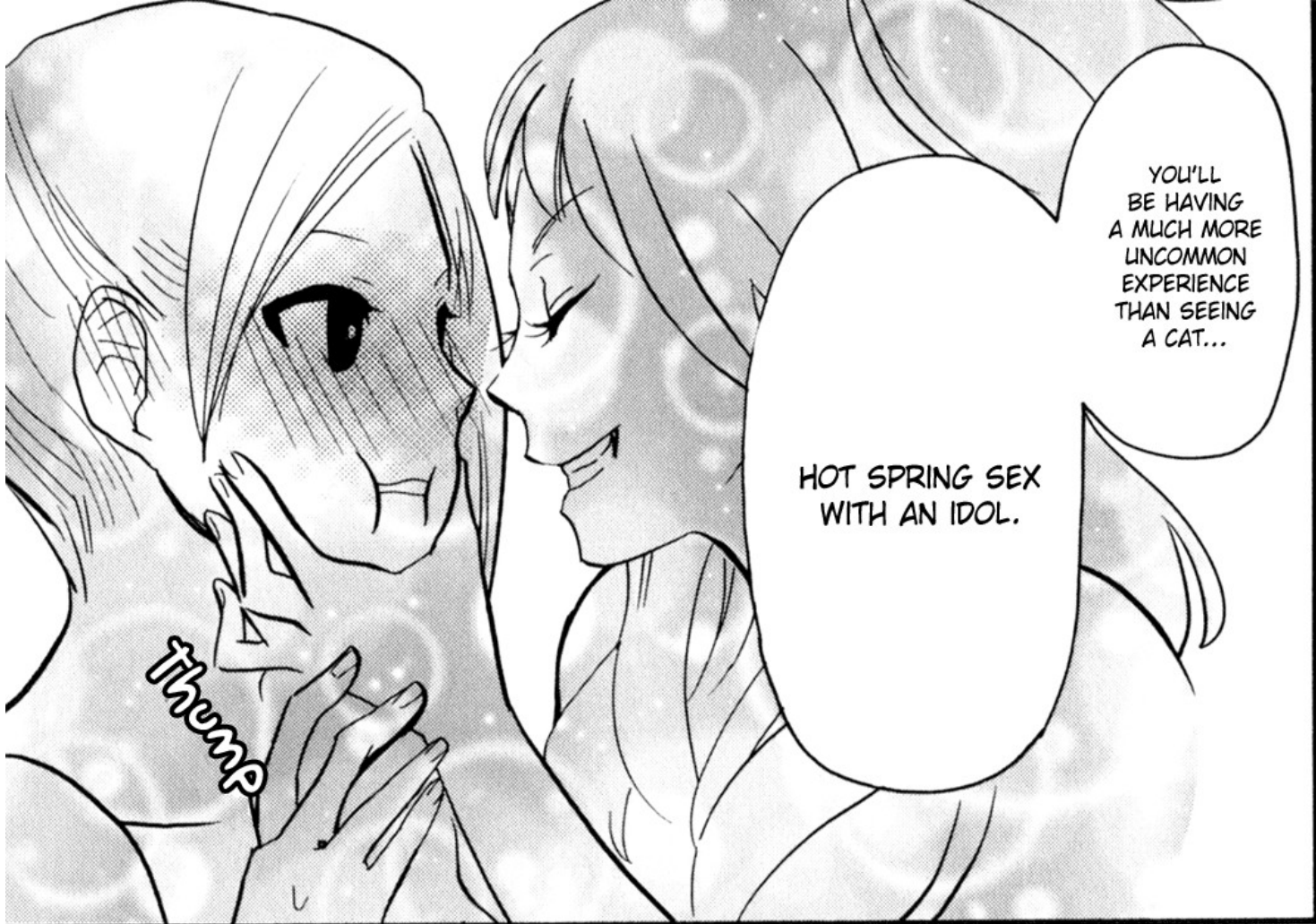

YOU'LL BE HAVING A MUCH MORE UNCOMMON EXPERIENCE THAN SEEING A CAT...

HOT SPRING SEX WITH AN IDOL.

Thump  
Thump



NOW THAT I THINK OF IT, I DON'T KNOW YOUR NAME YET.

Touch

Lick

Pant

Pant

AH,

Squeeze

Shudder

NGH...

Suck

Lick

N....

pant

pant

I... IT'S KUMI...

I get to have this look all to myself...

MARINA-CHAN ...



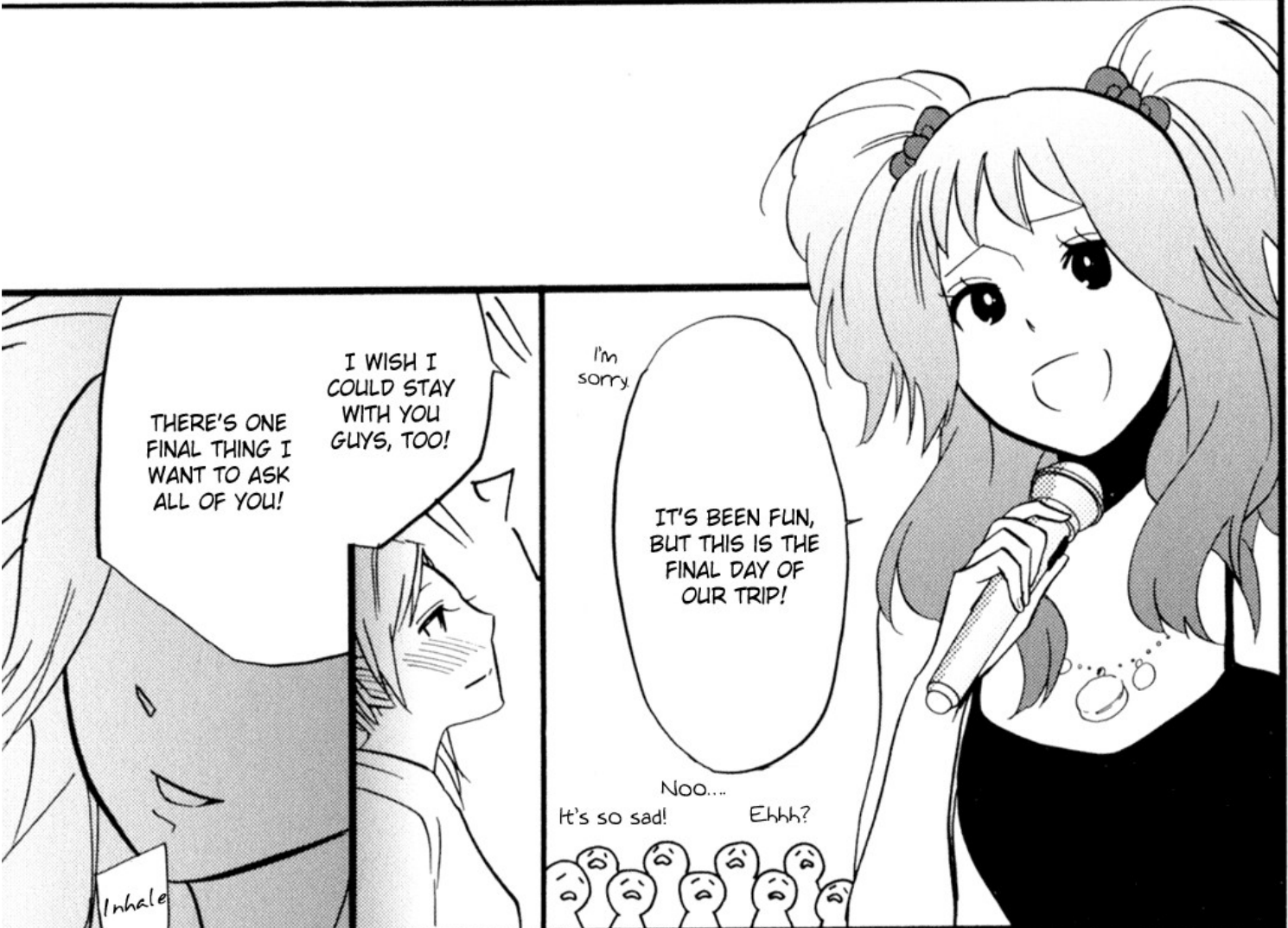

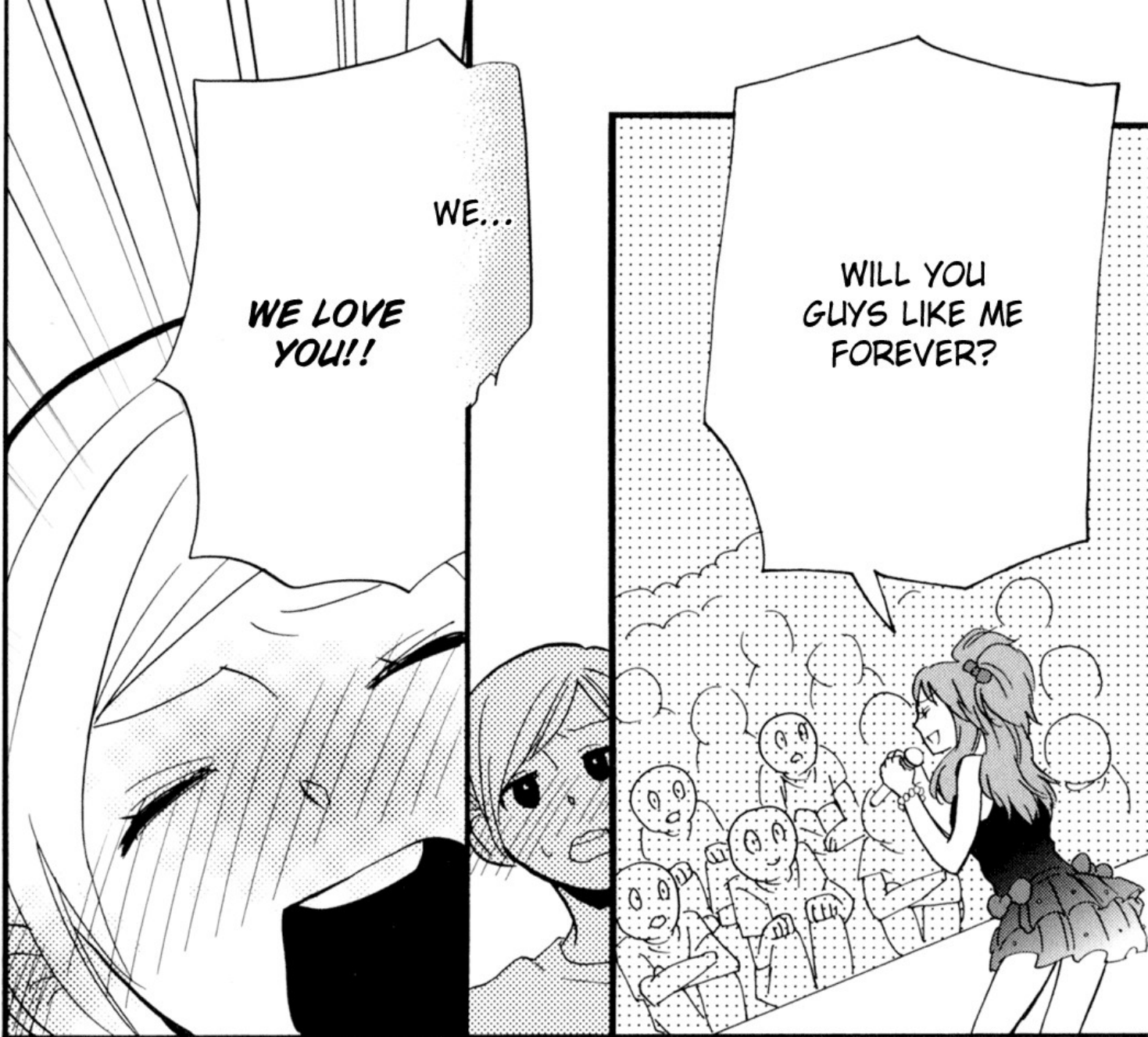

a steamy duet with Tranquil Spring & Payapaya Scans



Raws: Audio Erotica

Translator: Hitsuji-san

Proofreaders: Babelglyph & Shynaku

Editor: Kite

Quality Checkers: monkey, Shynaku & Audio Erotica



☪ FOURTH NIGHT ☪

**THE SEDUCTIVE HOUSE OF SECRET TREASURES**

**Sexy Museum**  
**Oniyuri Hiyouden**  
Entrance  
That way

世の必

For the first time in ten years!  
Disrobing our Secret Treasures  
August 29th

We have group discounts

Admission: 1000 Yen

Souvenir  
48-Position Handkerchief

Must be 18 or older to enter

Information

Rose-colored Fortune Telling



100 Yen

Do you take  
pride in your  
family's business?

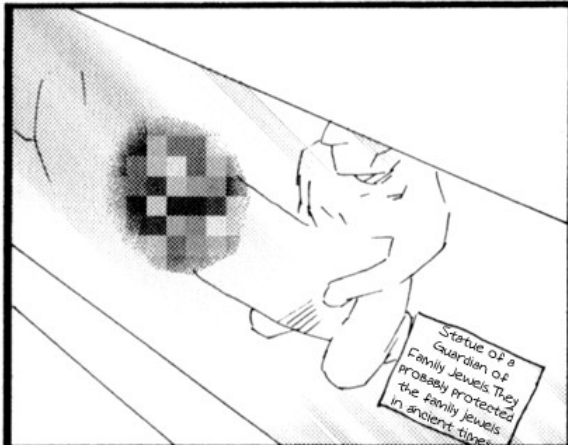

Statue of a  
Guardian of  
Family Jewels. They  
probably protected  
the family jewels  
in ancient times.

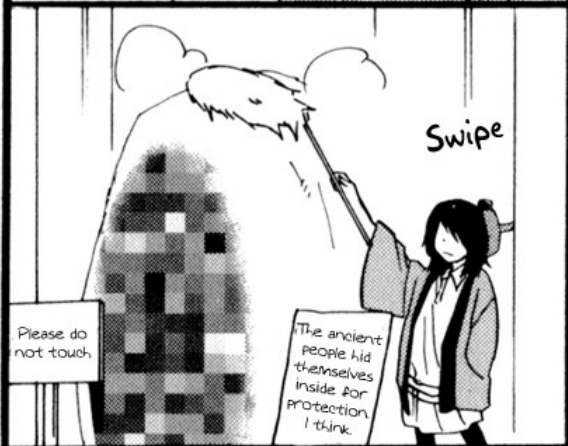

Swipe

Please do  
not touch.

The ancient  
people hid  
themselves  
inside for  
protection.  
I think.



This way

Sex Gods of  
the World

Bird-headed  
Goddess

Horse-headed Goddess

These were excavated by an  
anonymous contributor in an  
unknown year in an unknown place.  
An unknown person has created  
this for an unknown reason.

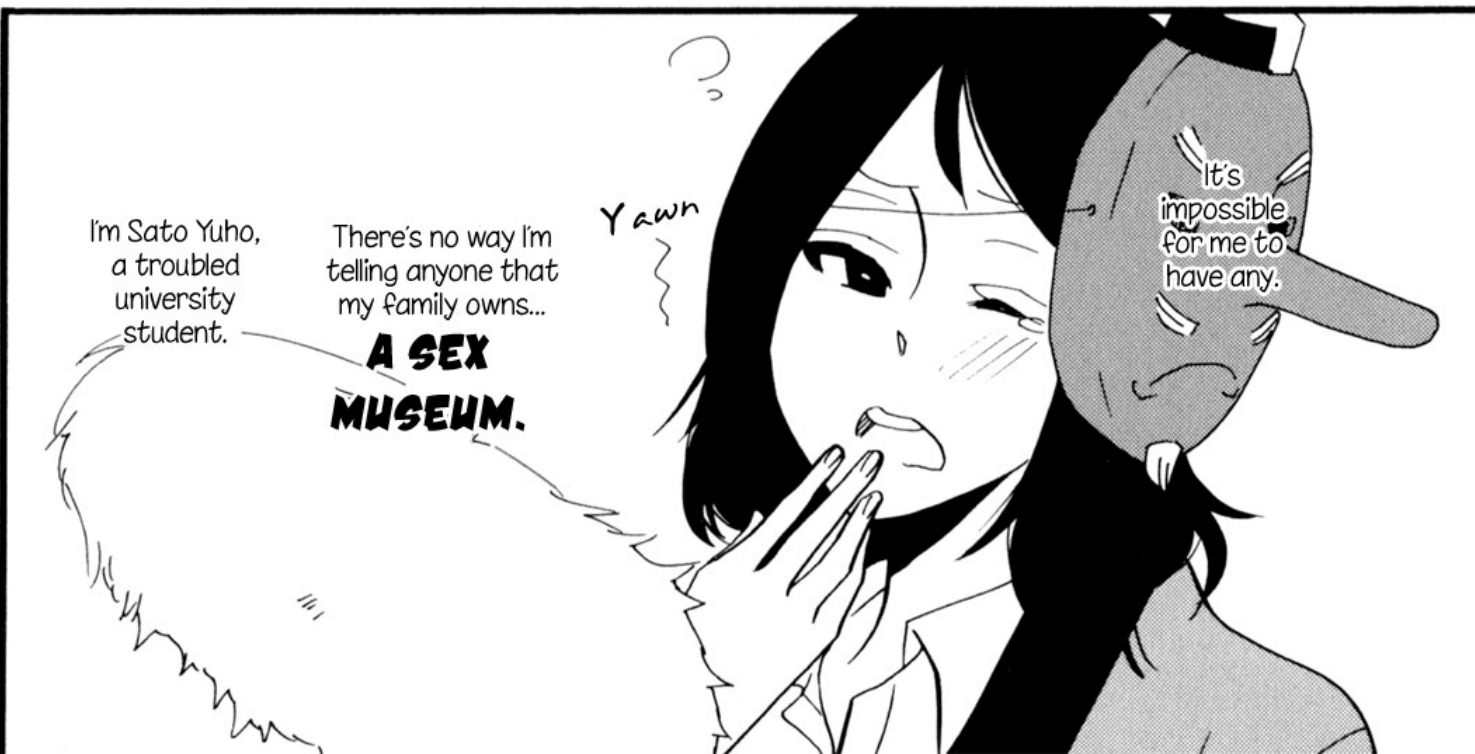

I'm Sato Yuho,  
a troubled  
university  
student.

There's no way I'm  
telling anyone that  
my family owns...

**A SEX  
MUSEUM.**

Yawn

It's  
impossible  
for me to  
have any.

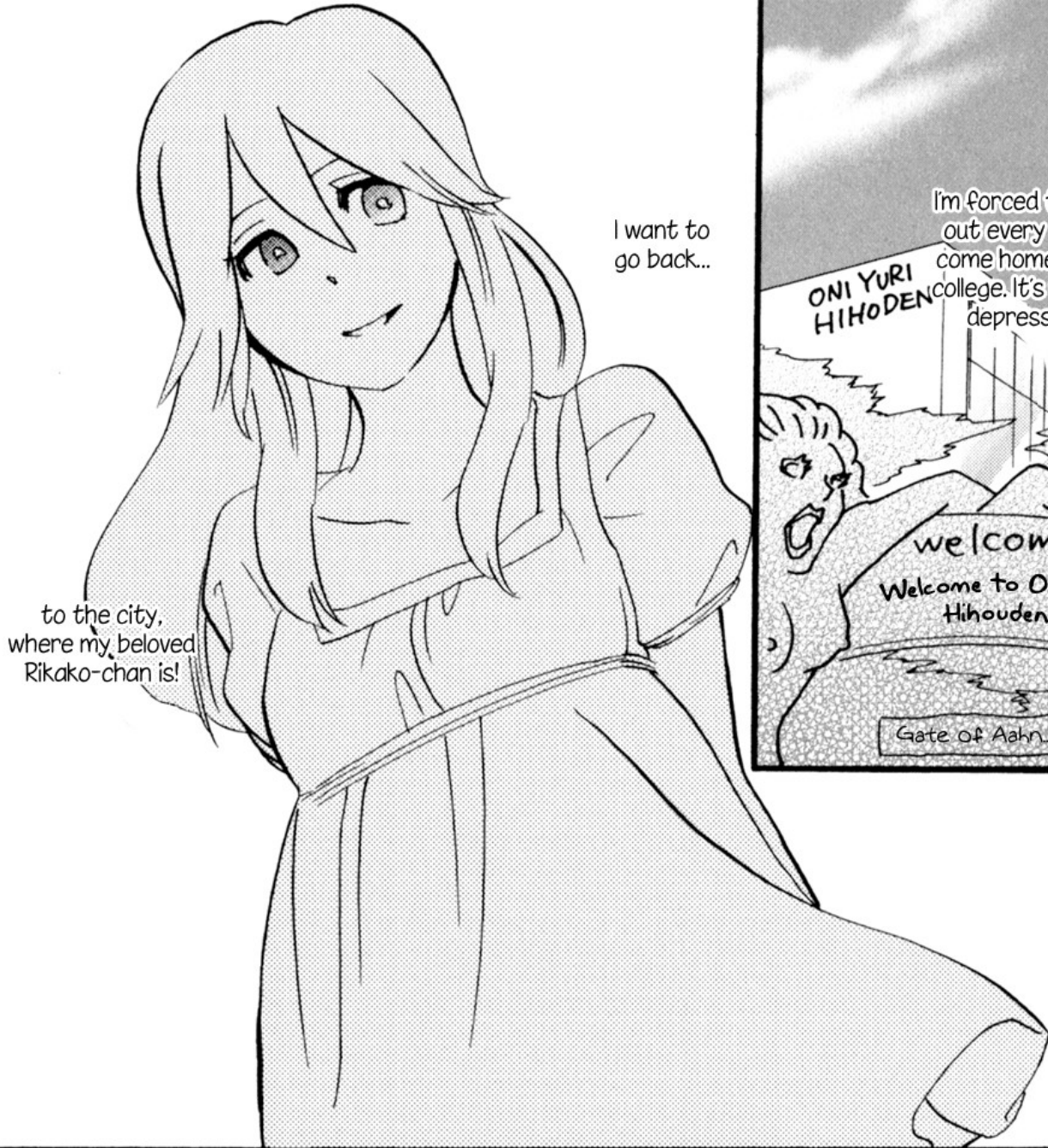

I want to go back...

to the city, where my beloved Rikako-chan is!



I'm forced to help out every time I come home from college. It's rather depressing.

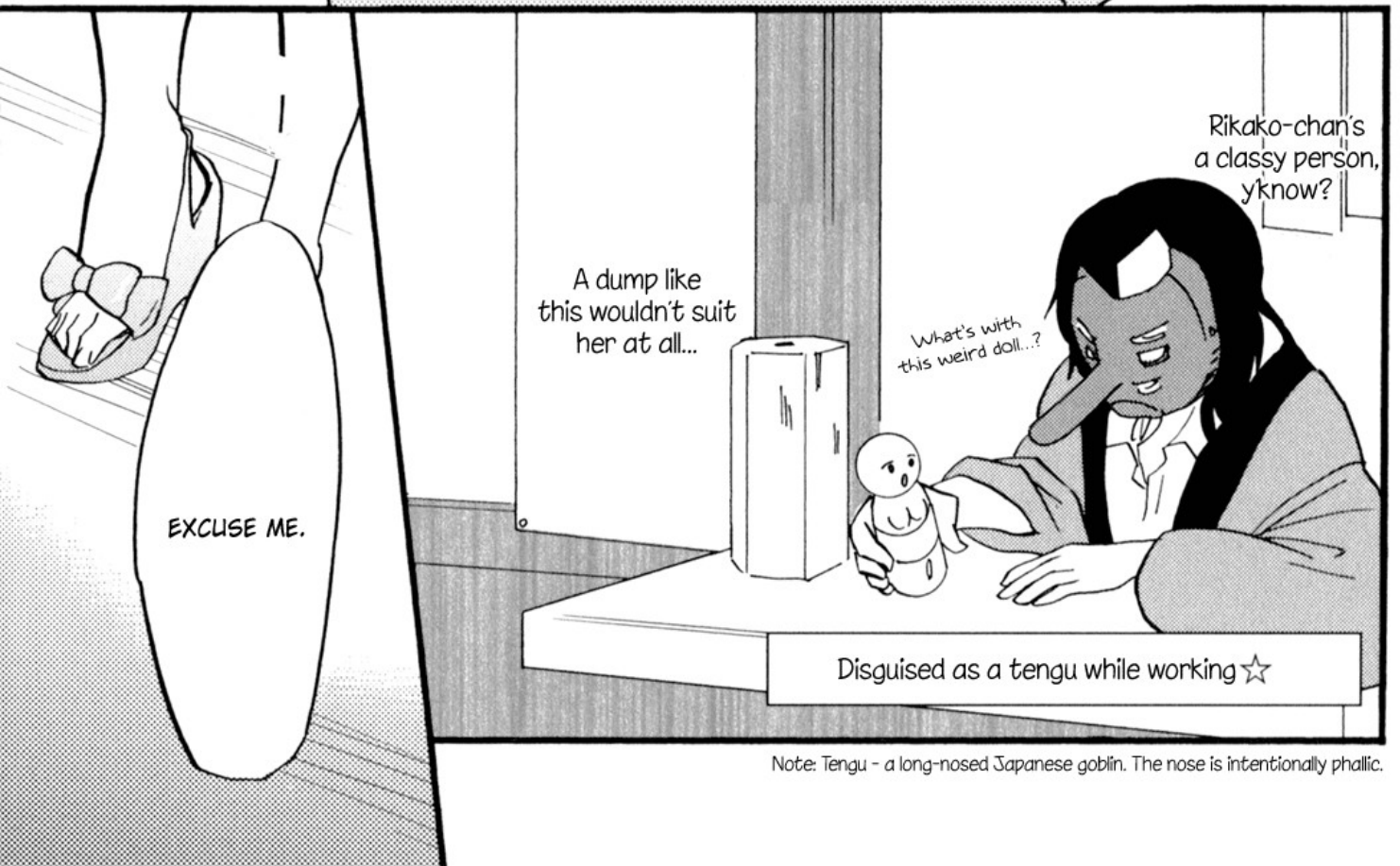

Rikako-chan's a classy person, yknow?

A dump like this wouldn't suit her at all...

What's with this weird doll...?

EXCUSE ME.

Disguised as a tengu while working ☆

Note: Tengu - a long-nosed Japanese goblin. The nose is intentionally phallic.

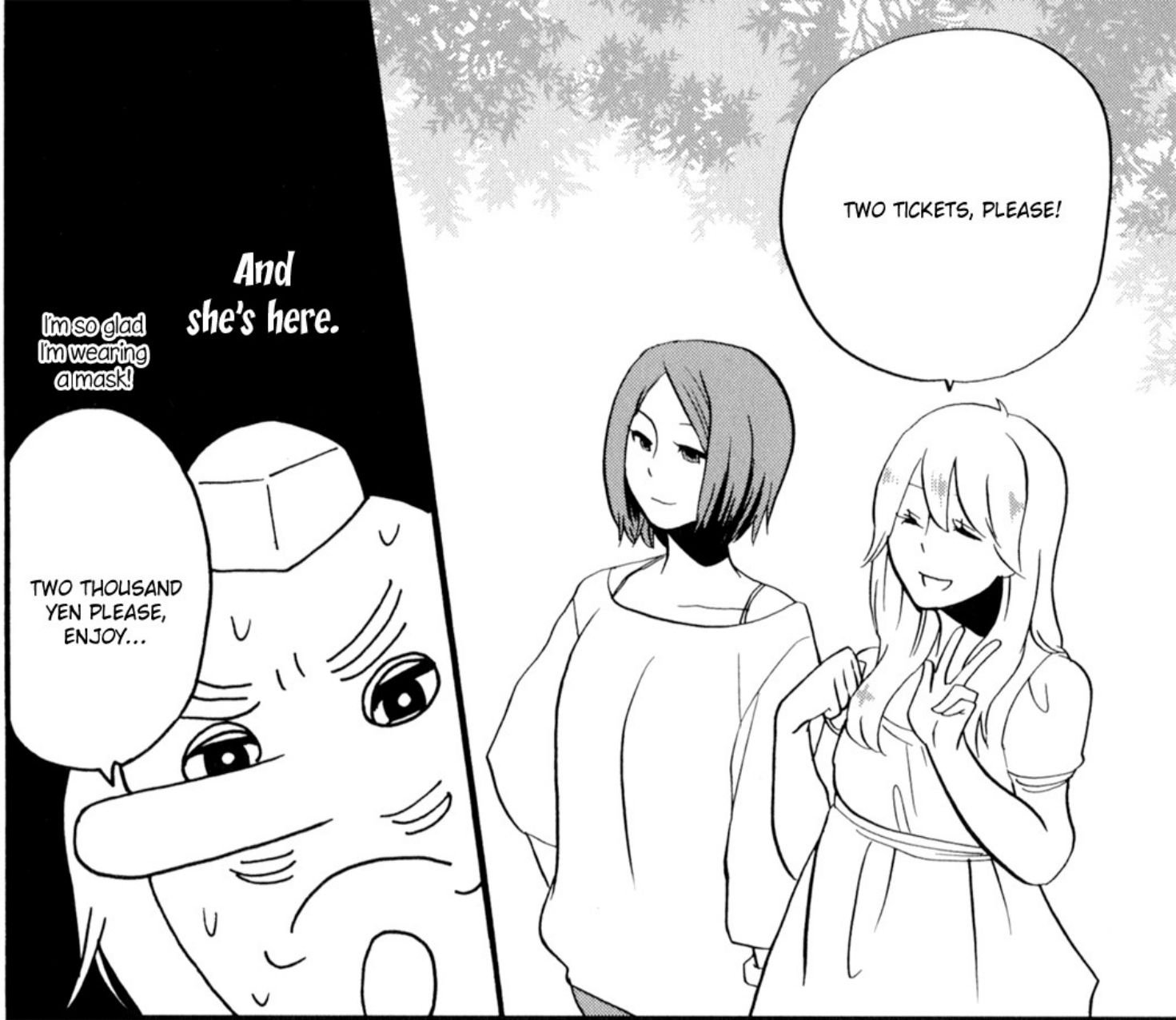

I'm so glad  
I'm wearing  
a mask!

And  
she's here.

TWO THOUSAND  
YEN PLEASE,  
ENJOY...

TWO TICKETS, PLEASE!

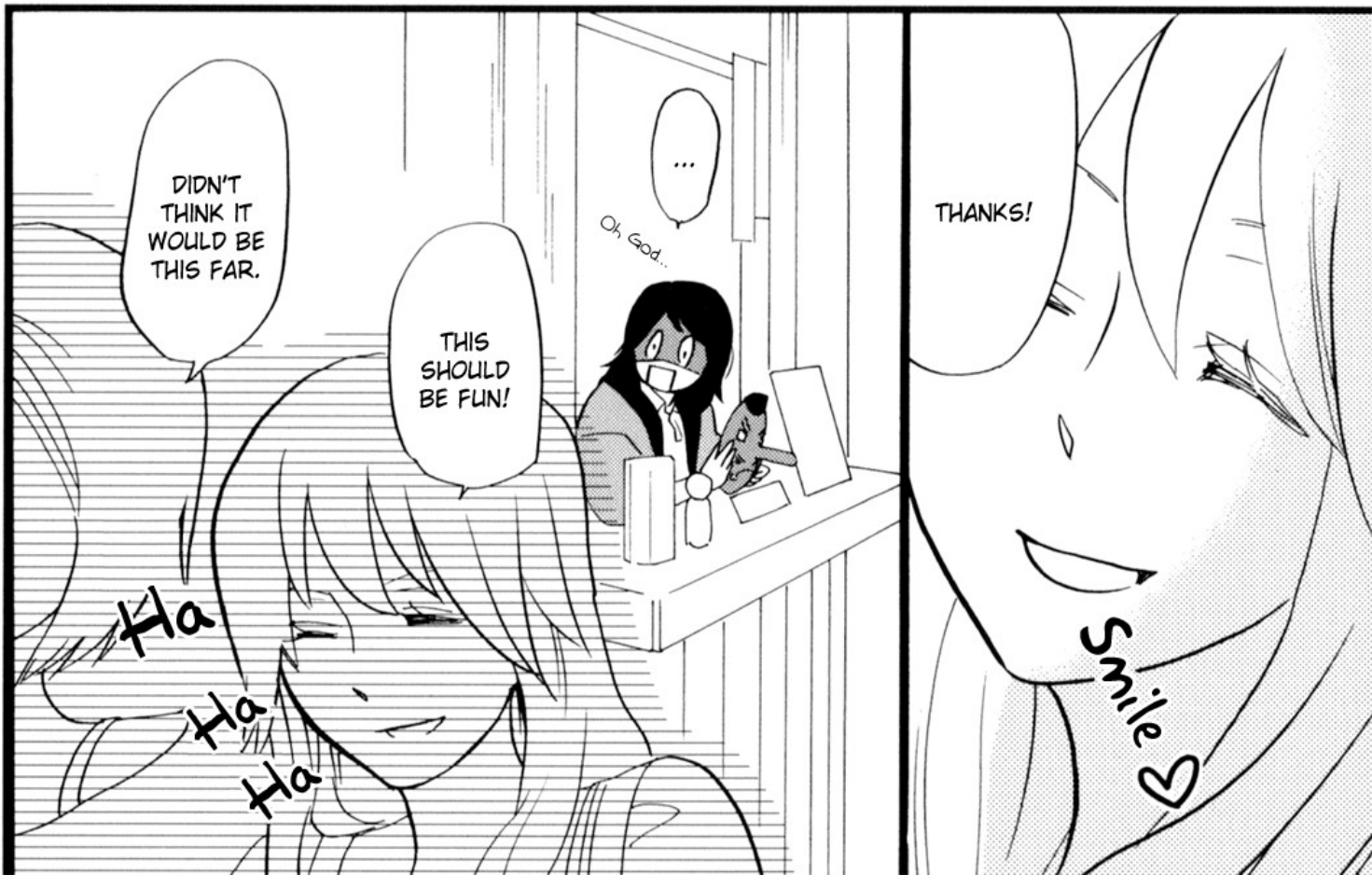

DIDN'T  
THINK IT  
WOULD BE  
THIS FAR.

THIS  
SHOULD  
BE FUN!

Oh God...

THANKS!

Smile ♡

Ha

Ha

Ha



No way!

Teehee

There's no mistaking it, that's her for sure.



Why is she here!?



And who's the other girl anyways?

What sort of relationship do they have!?

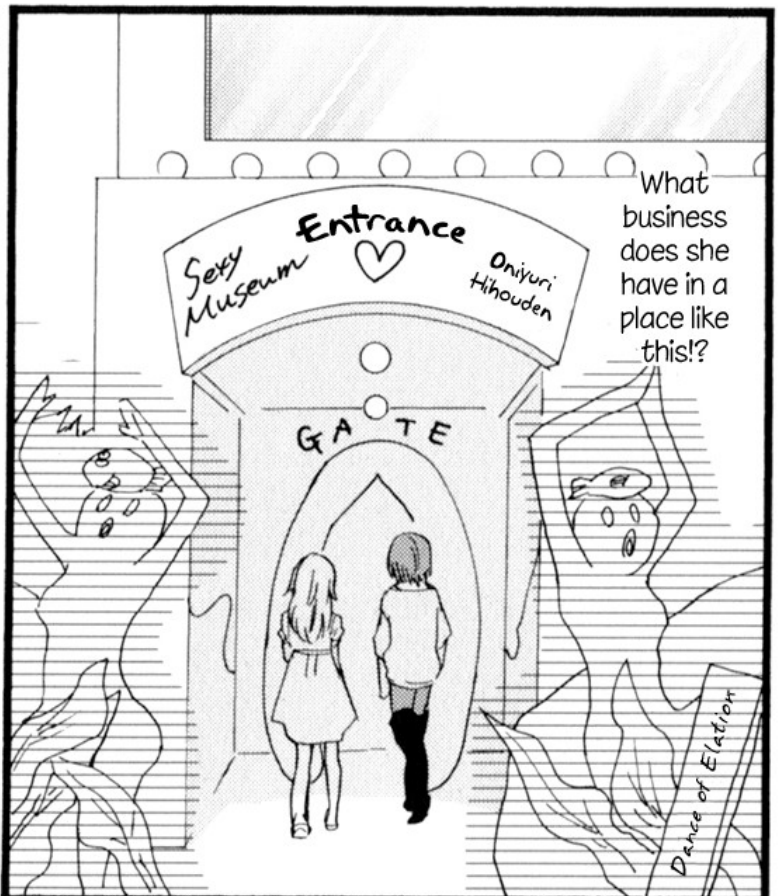

Sexy Museum Entrance  
Oniyuri Hihouden

GATE

What business does she have in a place like this!?

Dance of Elation



Bah! I don't get it at all!

And why does this place need to look so unnecessarily depraved in the first place?!

Coming to a sex museum in a rural hot spring town together... could they be... dating?

Arrrrghhh



YEAH,  
THERE ARE  
ALL KINDS  
OF STUFF.

LOOK!  
IT'S SO  
AMAZING!



I guess  
I should  
follow them...



So true

I'm so glad  
I was born  
human.



Looks like  
she's having  
fun... despite  
being in a  
place like this.

She has such  
a nice smile...



Is it because  
of that woman  
next to her?



I DON'T WANT TO SHOW MY FACE HERE...

I REALLY WANT TO GO OUT THERE AND ASK, BUT...

THIS IS DRIVING ME CRAZY! WHAT'S BETWEEN THOSE TWO?

Please do not climb on the display. Please do not stroke.

Mushroom Kingdom



I really hated it, so I studied my butt off and...

Waahhh!

Yeah! Pervert!

Haha! You're from the pervy house!

When I was a little girl, I was teased a lot about my family business.



THAT MEANS...

I BET THESE TWO ARE STAYING OVERNIGHT.

left for a college in a city far away.

Wow!

Boing

Ah!



Sex all night!



I'm so jealous!!

Damn it!

*crip*

*Tremble!*

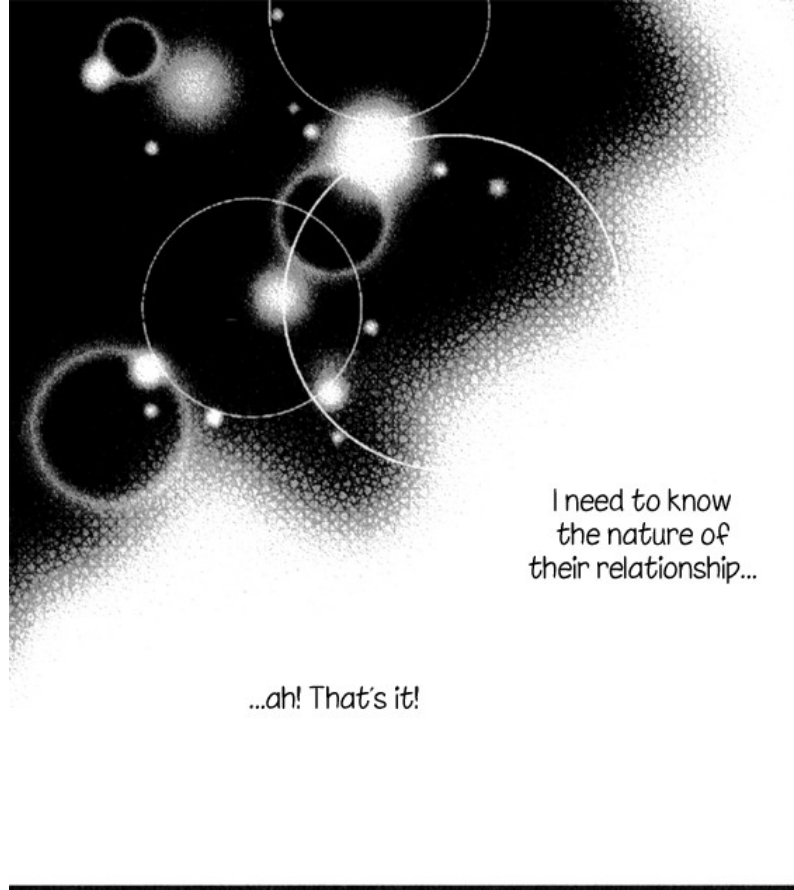

I need to know  
the nature of  
their relationship...

...ah! That's it!

Relax,  
Yuhō, it's okay!

BUT WAIT... IT'S STILL  
NOT CLEAR THAT  
THEY'RE TOGETHER...

Haa

Haa

Fume  
Fume

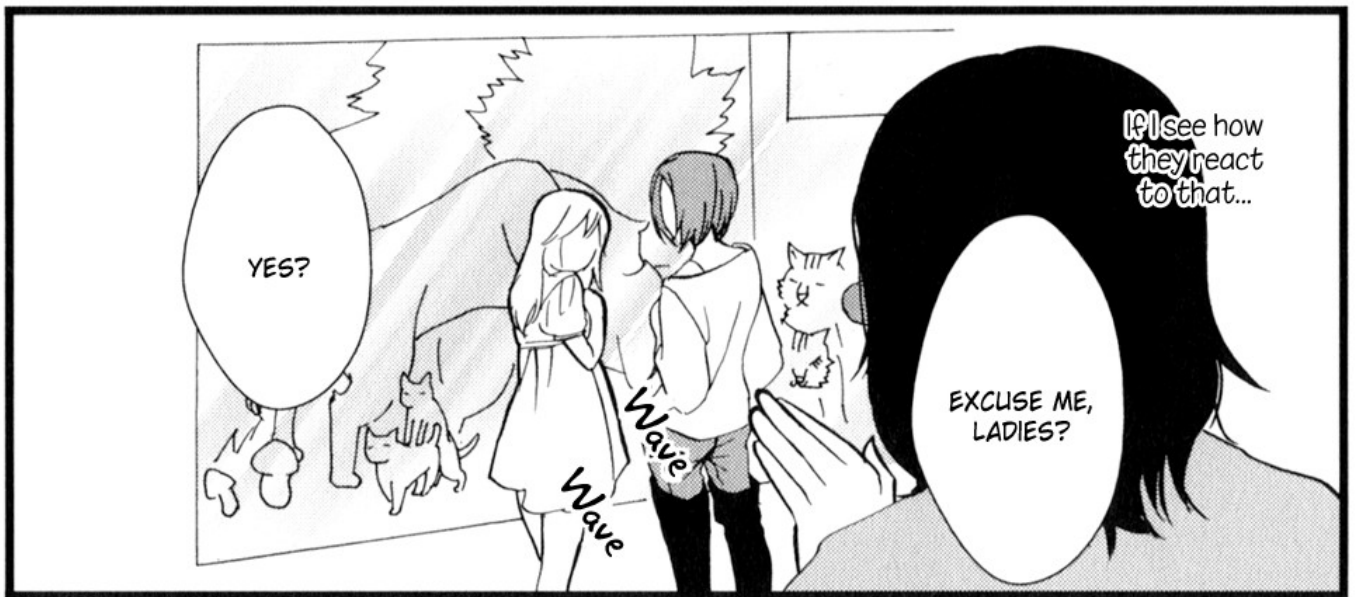

YES?

Wave  
Wave

I see how  
they react  
to that...

EXCUSE ME,  
LADIES?



HUH?



WHY DON'T  
YOU COME TAKE  
A LOOK AT OUR  
SACRED MONUMENTS  
OUTSIDE?



Which one will she choose!?

### The Sacred Caressing Stone

Happy Marriage,  
Safe Families,  
Fulfilled Relationships.

Caress it gently while thinking  
about the person you love,  
and your wish will come true.

They rubbed  
it together!!  
The female one!



**BOTH ETERNAL  
HAPPINESS!!**

I WISH YOU...

MY DEAR  
CUSTOMERS...

EH? OH,  
THANKS...

WELL  
THEN!

Here are some  
souvenirs!

Runs



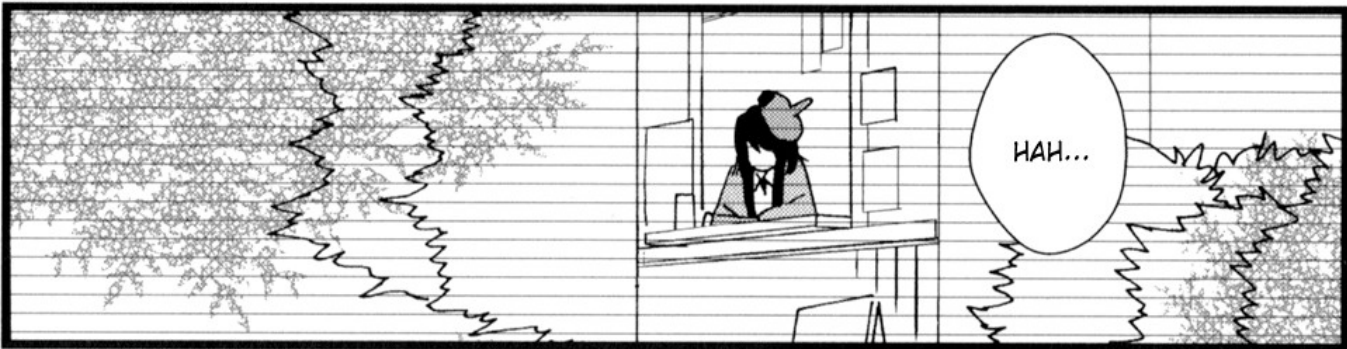

Life just doesn't go easy on me...



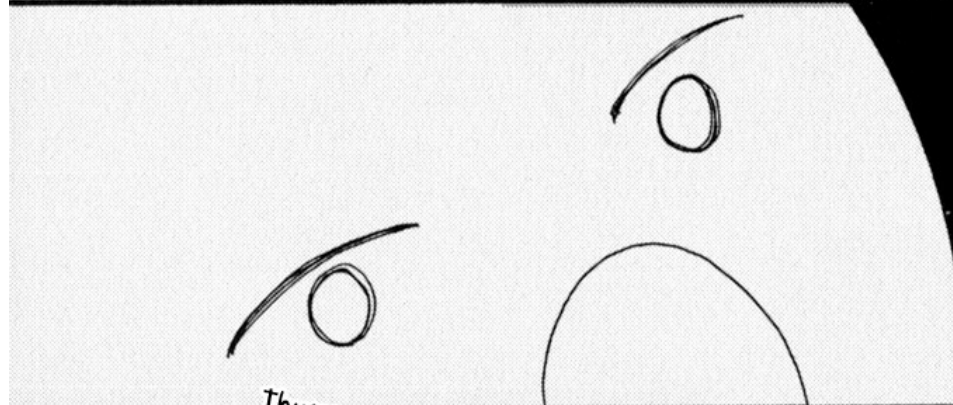
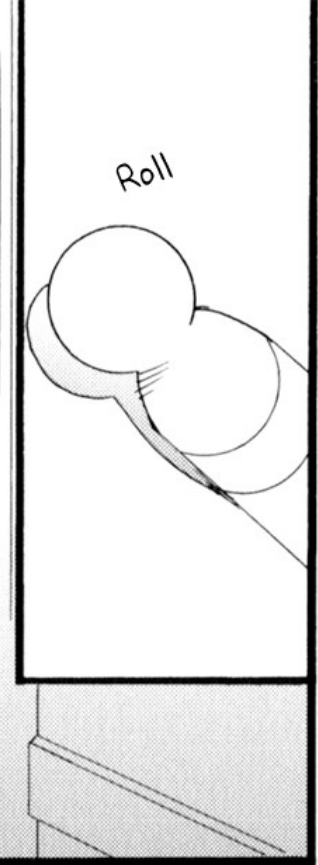

Hey, are you really okay with that?

Thump...



Don't you have any regrets?

Thump...



Did you really do all you could have done?



I haven't done a thing.

That's right.



Step

This house...  
The person I love...

All I've been doing is  
running and hiding  
from both of them!

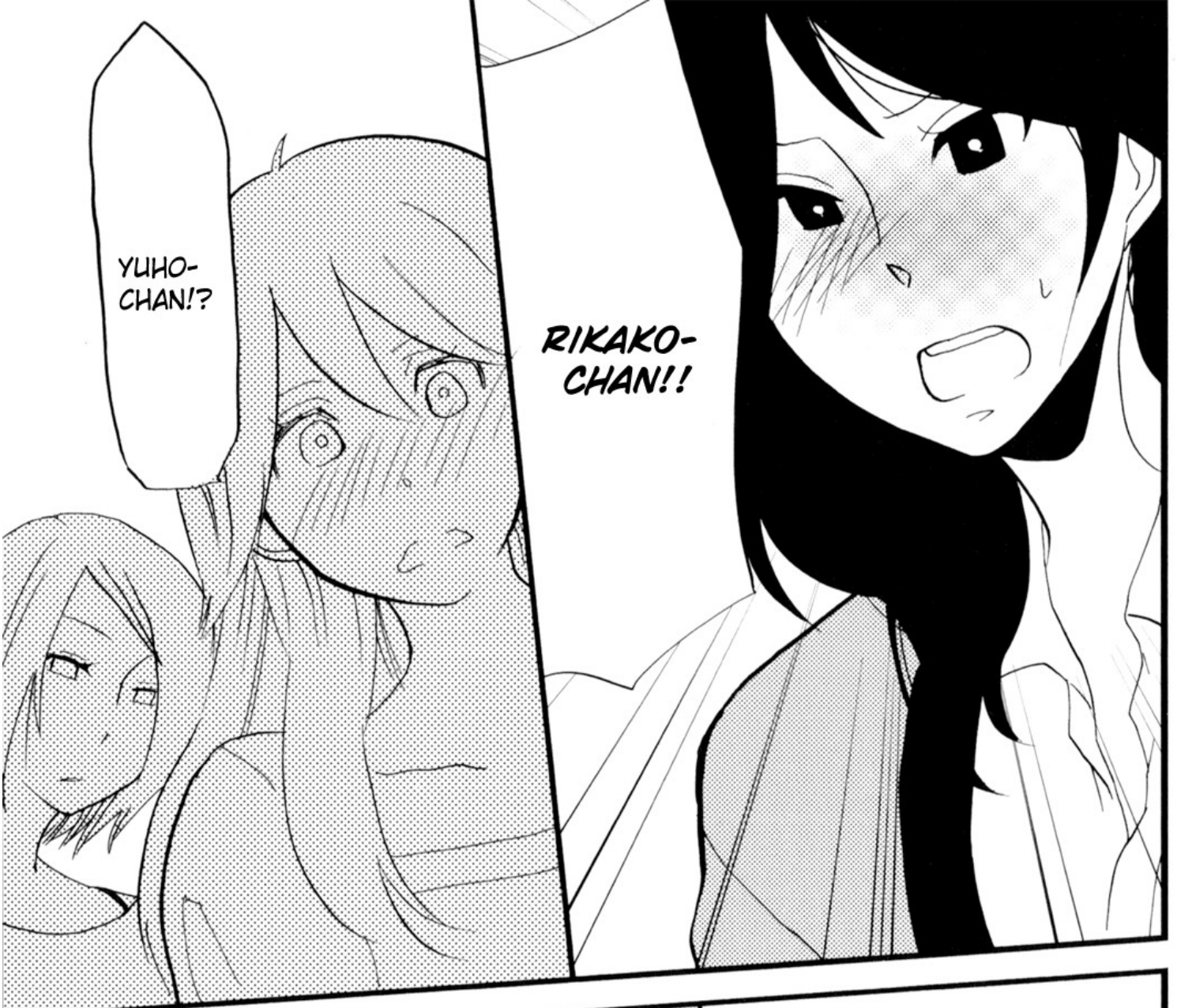

YUHO-  
CHAN!?

RIKAKO-  
CHAN!!



THERE'S  
SOMETHING I WANT  
YOU TO HEAR.

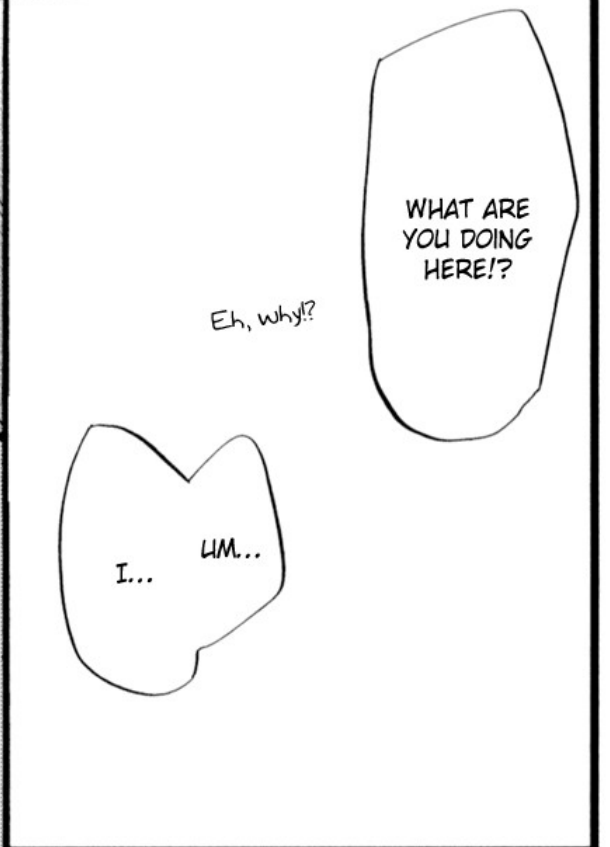

WHAT ARE  
YOU DOING  
HERE!?

Eh, why!?

I... UM...

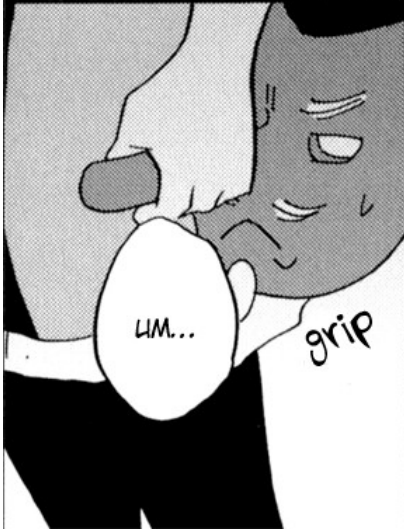

UM...

grip





EH?

Ba-dump



I...



I JUST WANTED YOU TO KNOW...

EVEN IF YOU'RE ALREADY WITH SOMEONE...

Cringe



I LIKE YOU, RIKAKO-CHAN.



HUH.

...



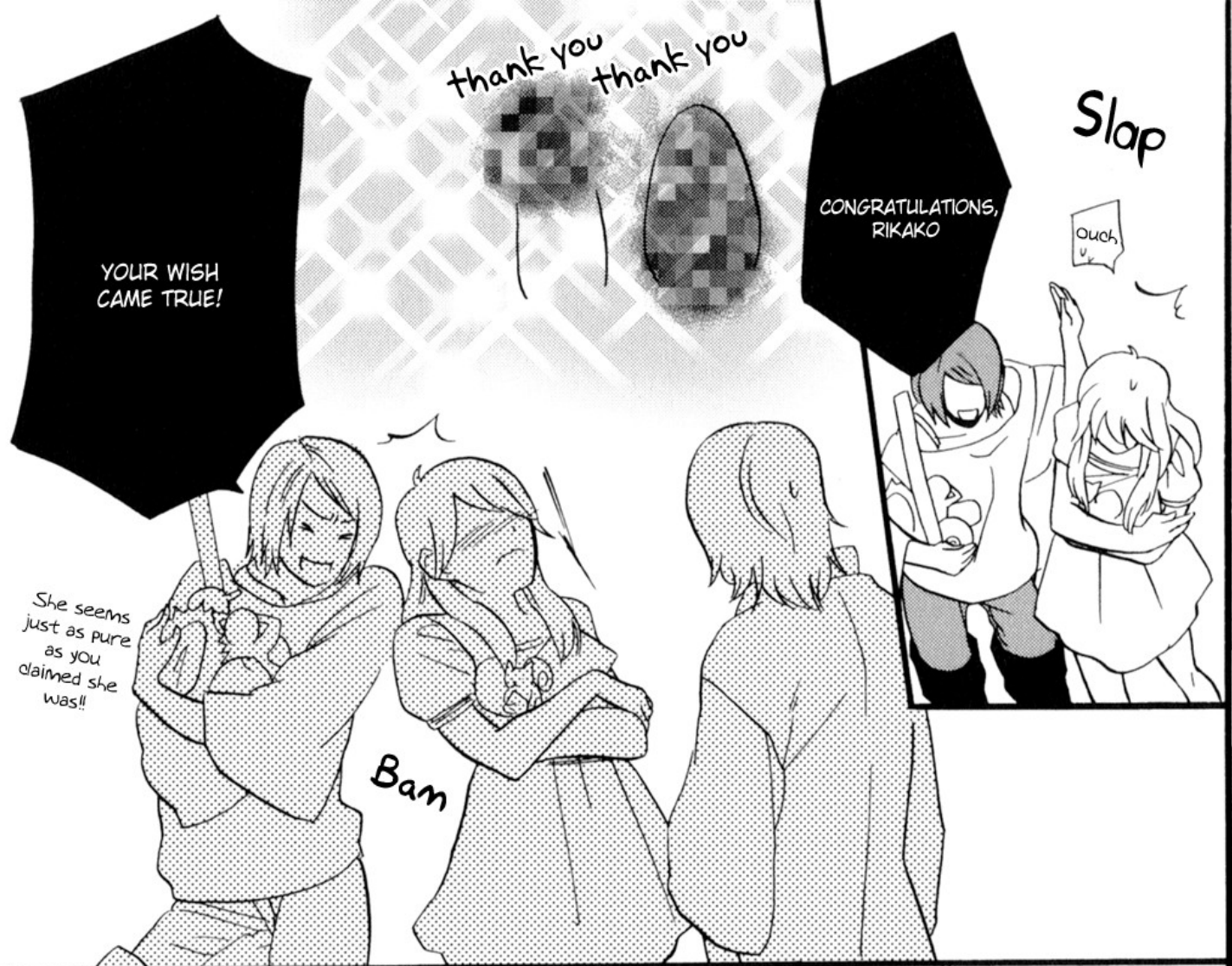

YOUR WISH CAME TRUE!

thank you  
thank you

CONGRATULATIONS,  
RIKAKO

Slap

Ouch

She seems  
just as pure  
as you  
claimed she  
was!!

Bam



I'll take the  
souvenirs  
though!

OKAY.

WELL, I GUESS  
THIS THIRD  
WHEEL SHOULD  
BE GETTING  
HOME...

Wha...?

Stunned

YEP.

...

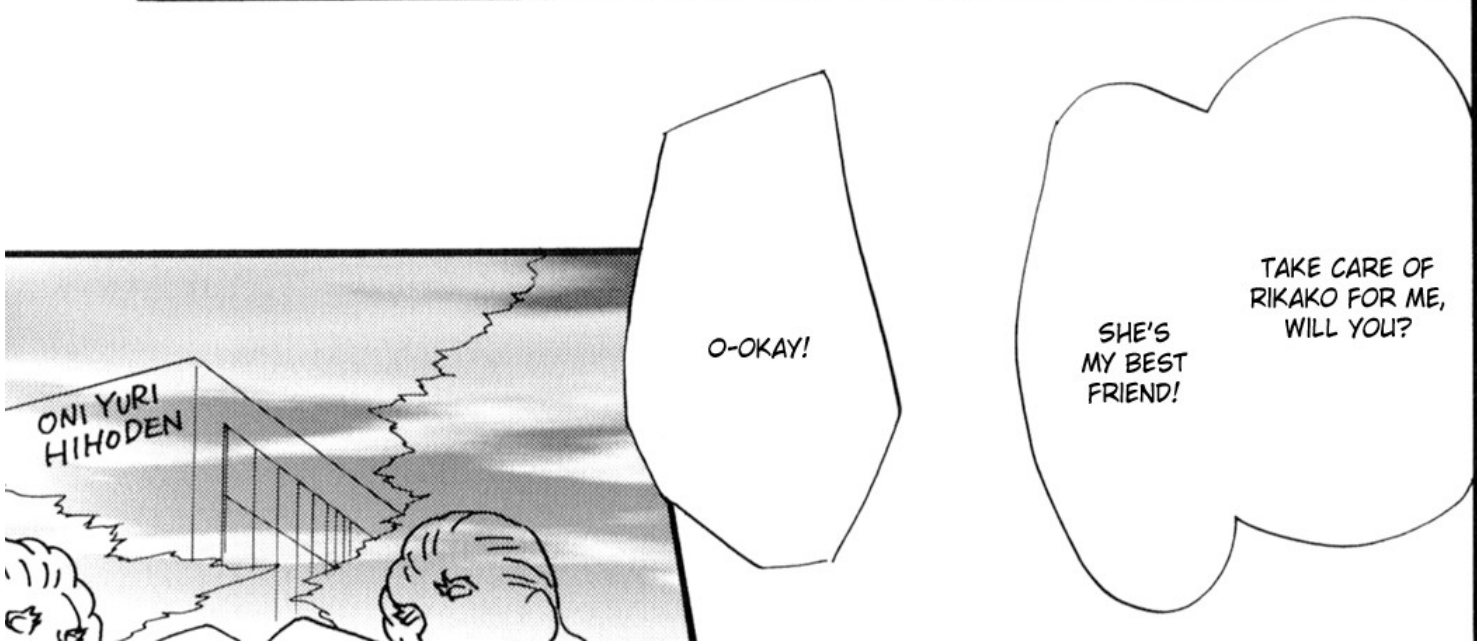

ONI YURI  
HIHODEN

O-O-KAY!

SHE'S  
MY BEST  
FRIEND!

TAKE CARE OF  
RIKAKO FOR ME,  
WILL YOU?



IT'S SO EMBARRASSING.

THIS IS MY FAMILY'S PLACE...

I BET YOU WERE SURPRISED.

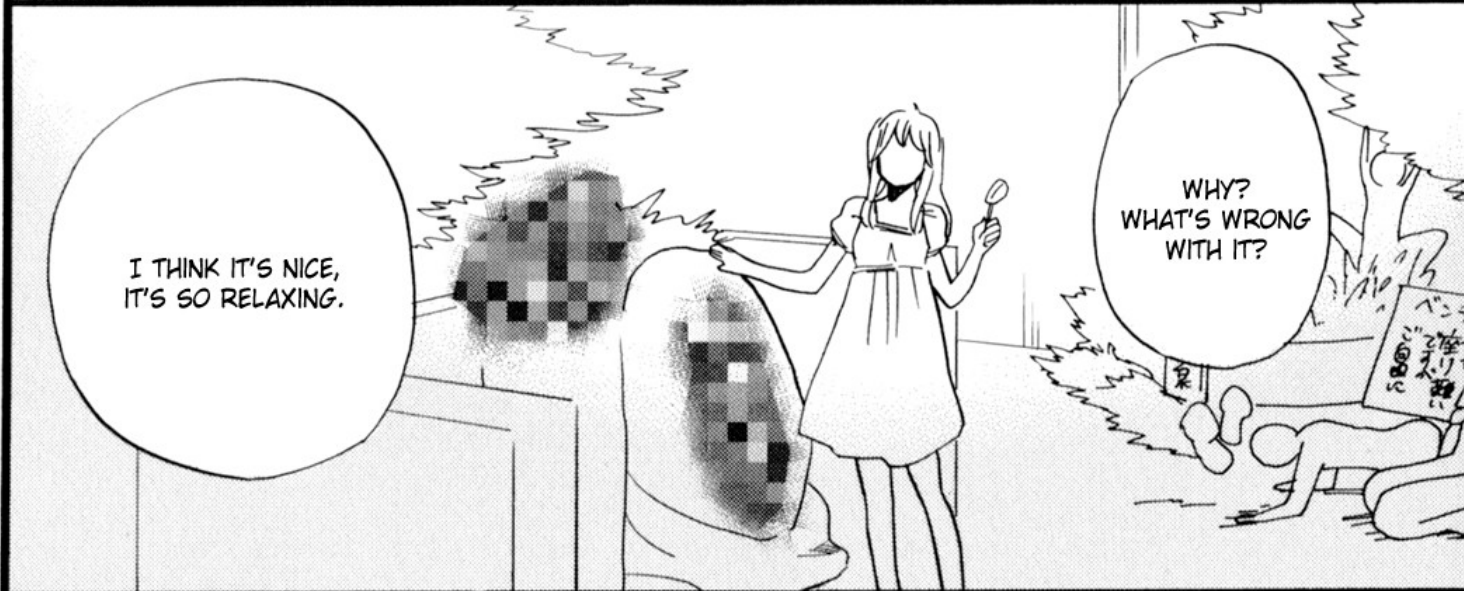

I THINK IT'S NICE, IT'S SO RELAXING.

WHY? WHAT'S WRONG WITH IT?



For the first time in my life...

...THANKS.



I could be proud of my home.



I.. LIKE IT.



HEY,  
I DECIDED TO  
STAY ONE MORE  
NIGHT, SO...

CAN I STAY  
OVER?

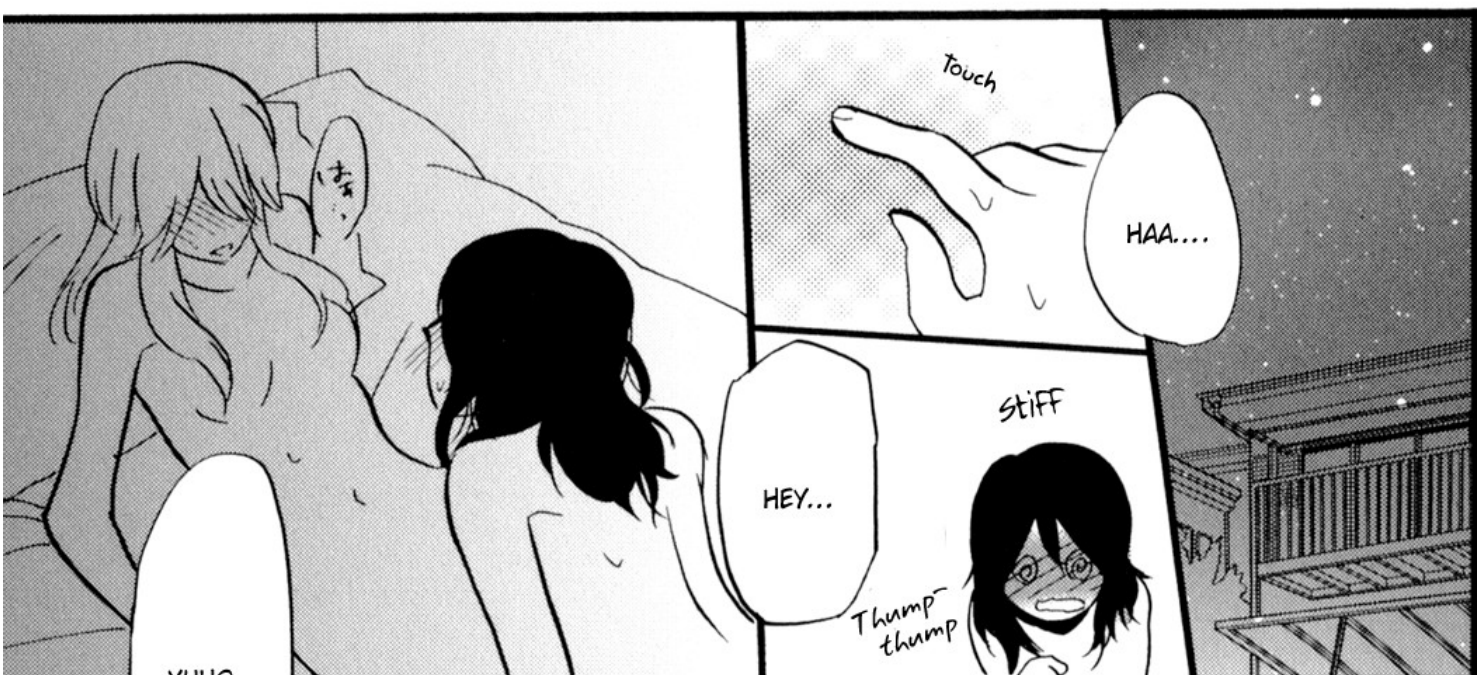

YUHO-  
CHAN...

HEY...

Touch

HAA....

stiff

Thump  
thump



IS THIS YOUR...  
FIRST TIME?

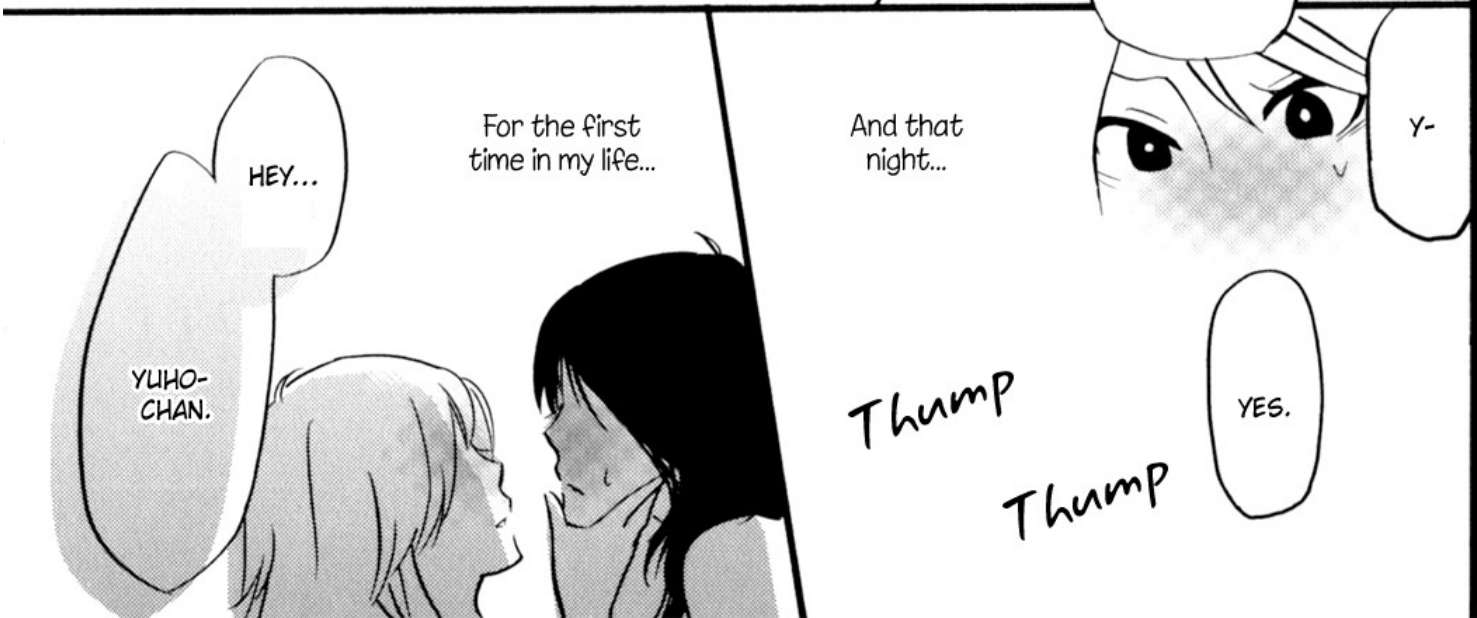

HEY...

YUHO-  
CHAN.

For the first  
time in my life...

And that  
night...

y-

Thump  
Thump

YES.



AHHHH.....



...Raw beauty,

I learned the beauty of the human form.

HA... NGH...

YOU CAN BE A LITTLE ROUGHER WITH ME... YOU KNOW?

NN... AH... AHH...

tremble

SHOCK

tremble



And...



I promised myself that I would turn my house into the greatest sex museum in Japan.



I'll DO MY BEST!!

Yeehaw!

Yuhoo, what's wrong!? Did you hit your head somewhere!?

I'll TAKE OVER THE FAMILY BUSINESS ONCE I GRADUATE!

MOM,



Tranquil Spring and Payapaya Scans present...

Yukemuri Sanctuary - Chapter 04

Raws: Audio Erotica

Translator : Hitsuji-san

Proofreader : Babelglyph

Editor: Kite

Quality Checkers: Evangel, Audio Erotica, Babelglyph

**TWO OLS ON COMPANY VACATION**



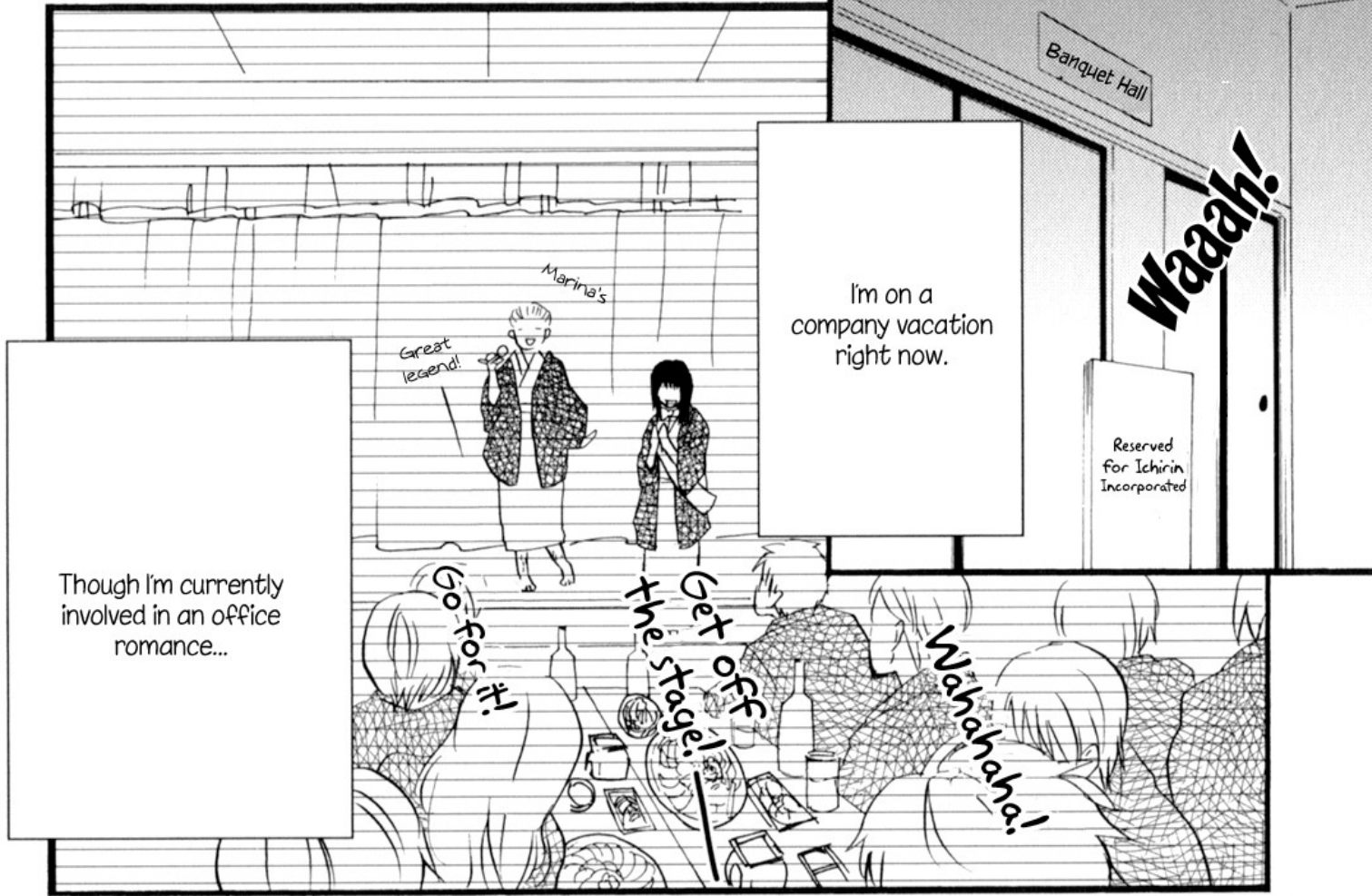

Though I'm currently involved in an office romance...

I'm on a company vacation right now.

Reserved for Ichirin Incorporated

Waaaah!

Great legend!

Marina's

Go for it!

Get off the stage!

Wahahaha!



Young people these days are amazing!

clap  
clap

I, Wakaba, am currently being completely ignored.



So why did you take on the role of Party Hostess?

Sure, it's with the whole company, but we're still on a vacation together.

...that's what I want to ask my girlfriend, Tami.

In the host.

But...

I've been waiting for this!

Next up is our trio of new female employees!

She's a kind person who can't say no when asked a favor.



What's up with that Bowtie?

Honestly, I'm getting bored...

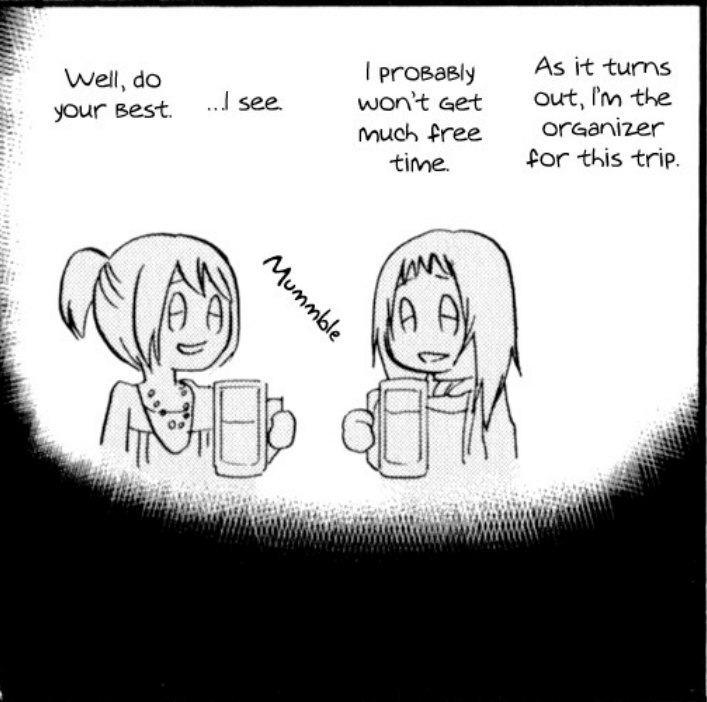
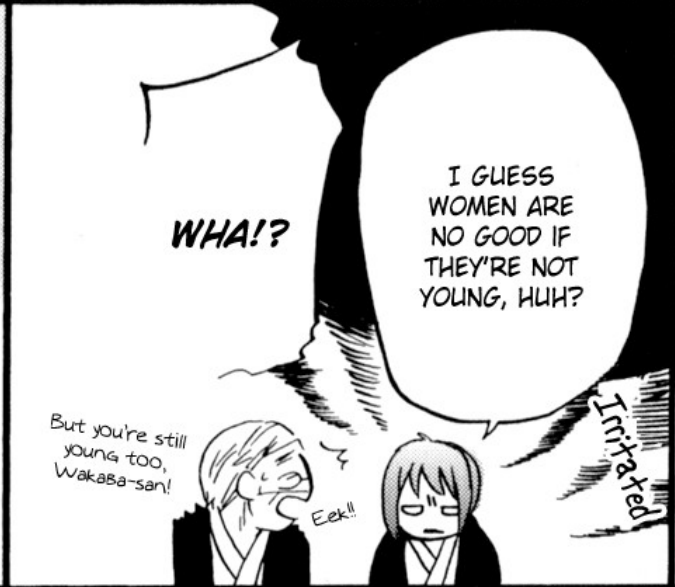
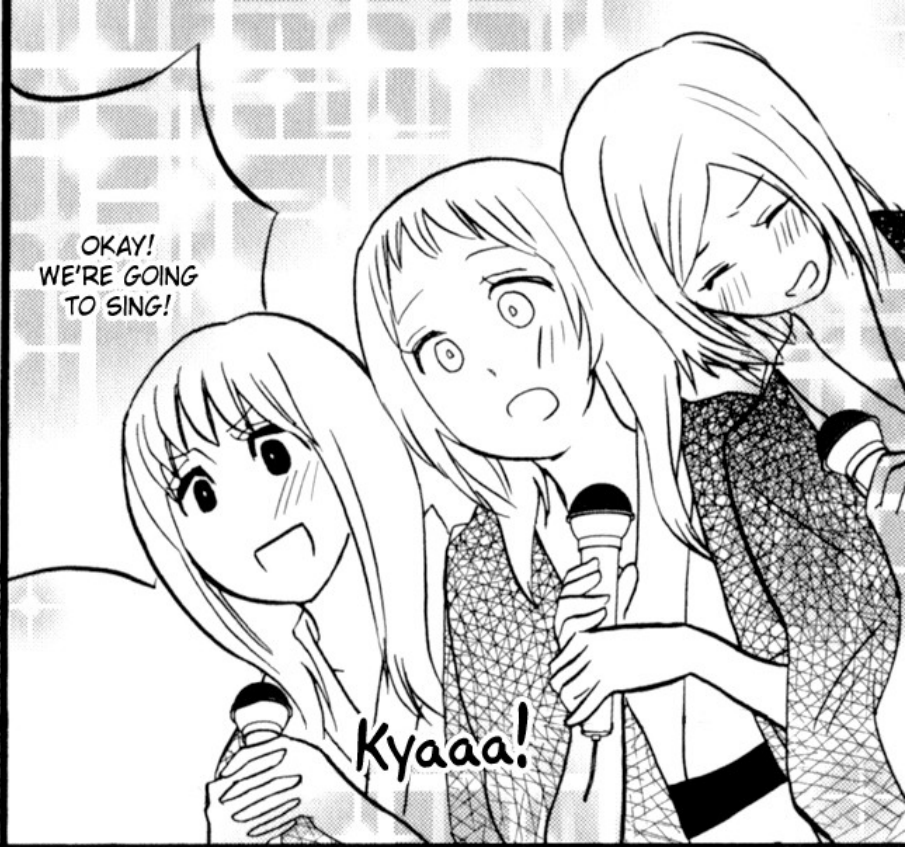

I'M GONNA GO  
GET SOME AIR.

I'M GETTING A  
LITTLE DRUNK.

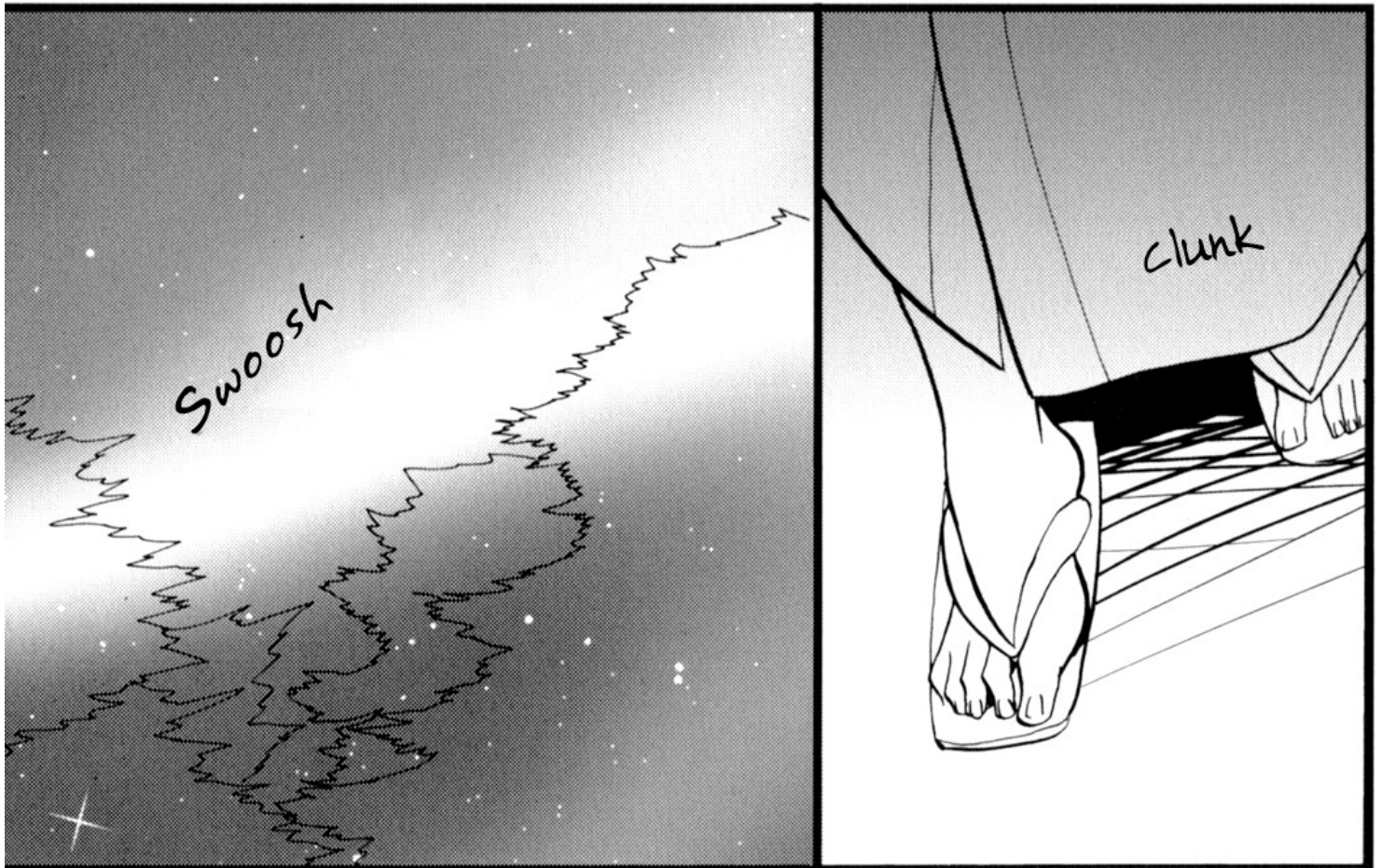



Let's go!  
Shall we go  
somewhere  
after work  
today?

When we first  
started going out,  
we were together  
all the time.



Maybe it's natural  
to have this kind  
of distance after  
three years.



But now, it's like  
we've reverted back  
to being friends.

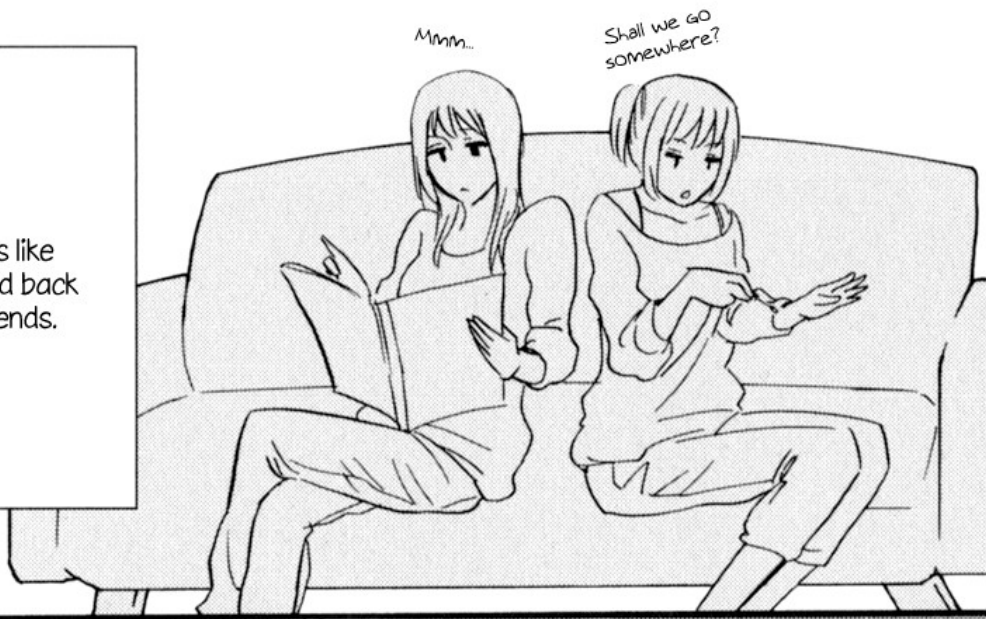

Mmm...

Shall we go  
somewhere?



When was the last  
time we had sex?

When I think  
about it...



Hey Tami, come after me.

Maybe she doesn't see me as a woman anymore.

I guess that's a funny thing to say when we're both girls.



As if that'll happen...



OH, WHAT'S THAT?



I wonder if there's a gift store open...

...THERE AREN'T MANY PLACES TO KILL TIME DURING THE NIGHT...

Wobble wobble



HEY HEY!  
WELCOME,  
WELCOME!

Ten shots  
a play for  
five-hundred  
yen.



Shooting  
Game?

Oniyuri  
Shooting Game



...WELL,  
I GUESS YOU  
CAN SAY THAT.

HOW RUDE!!

WELL, AREN'T  
YOU LOOKIN' A  
LITTLE STALE,  
YOUNG LADY!

AH!

ALTHOUGH  
SHE'S NOT  
A MAN.

DIDYA HAVE A  
FIGHT WITH  
YOUR MAN?



COME ON  
NOW, THIS  
ONE HERE  
IS SUPER-  
EFFECTIVE!

Why!?

Well,  
that's no  
good!  
You'll have  
to play  
then!

Five  
hundred  
yen, please!  
Thanks.

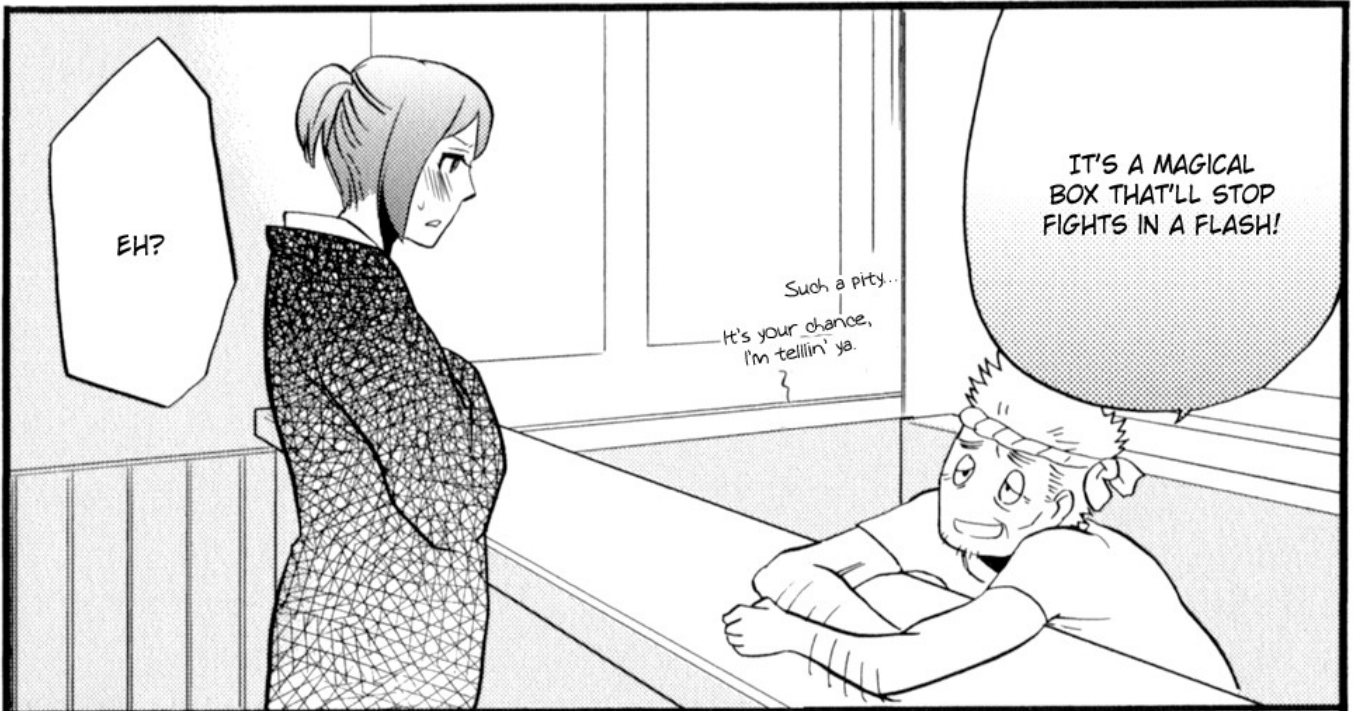

EH?

Such a pity...  
It's your chance,  
I'm tellin' ya.

IT'S A MAGICAL  
BOX THAT'LL STOP  
FIGHTS IN A FLASH!



Magic to  
help us  
make up...

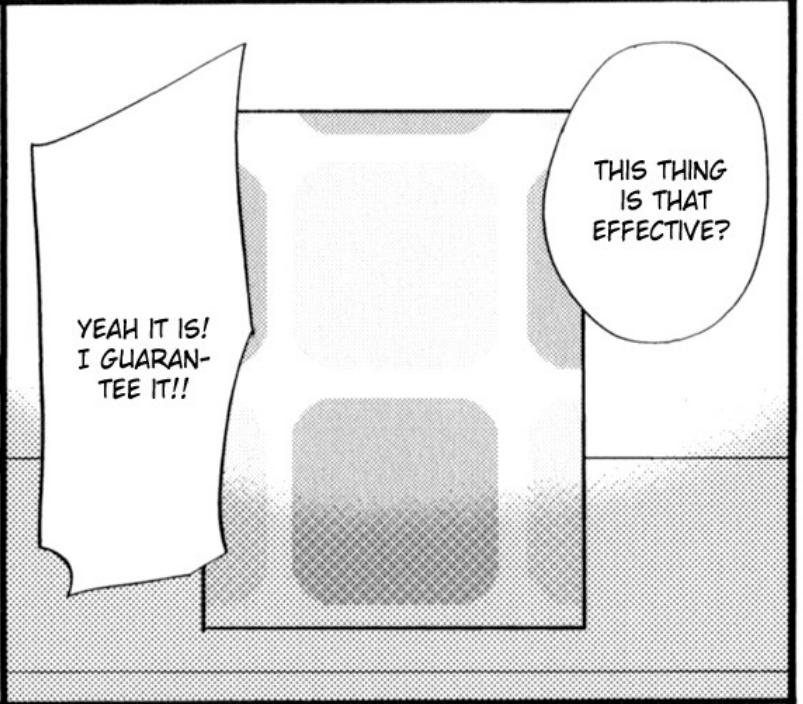

YEAH IT IS!  
I GUARAN-  
TEE IT!!

THIS THING  
IS THAT  
EFFECTIVE?

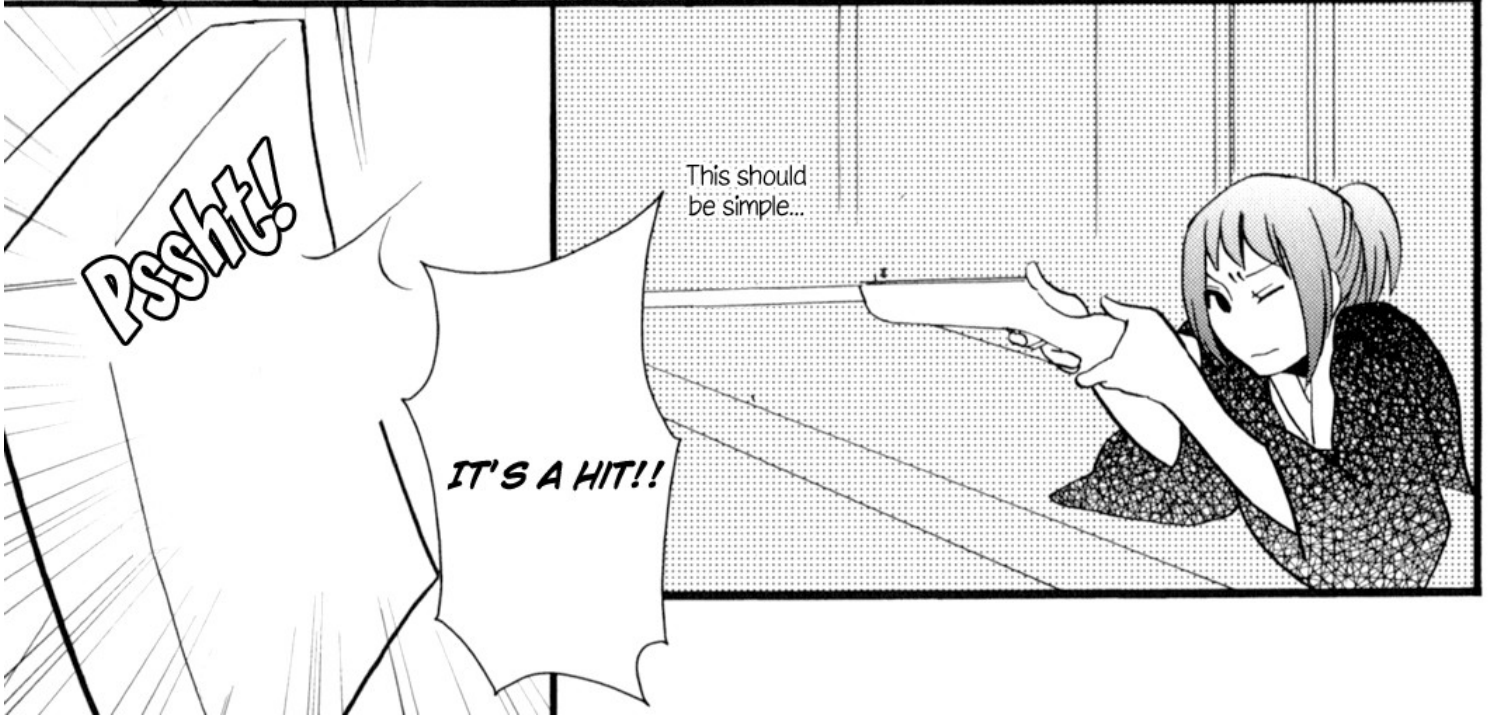

Pssh!!

IT'S A HIT!!

This should  
be simple...

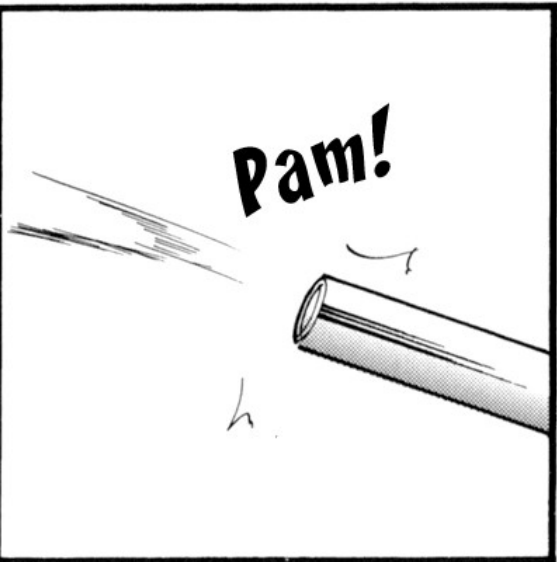
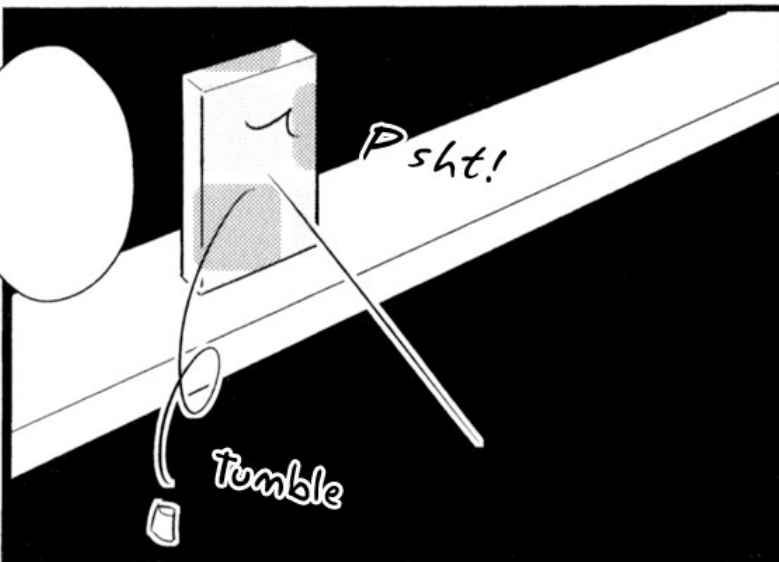
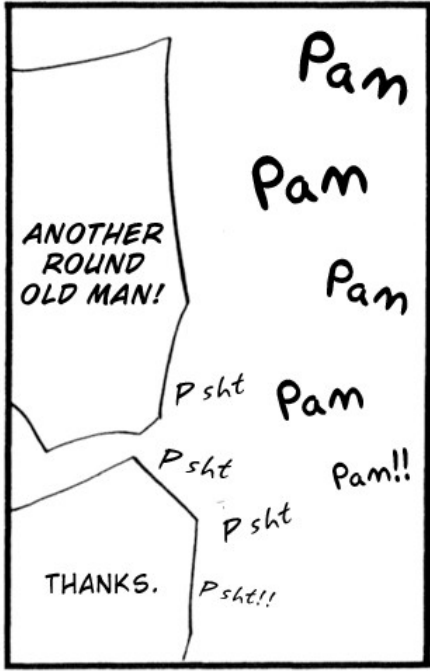
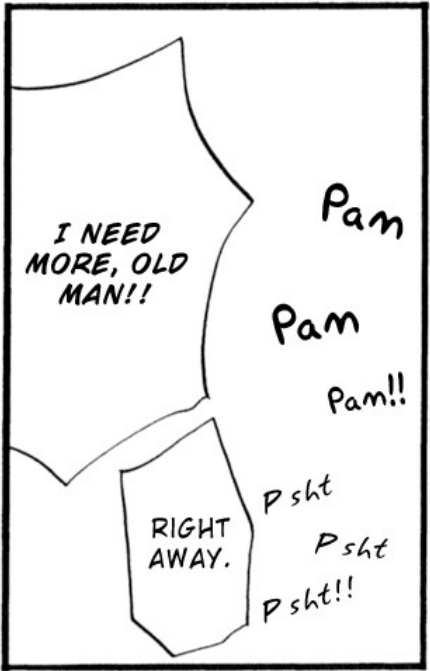
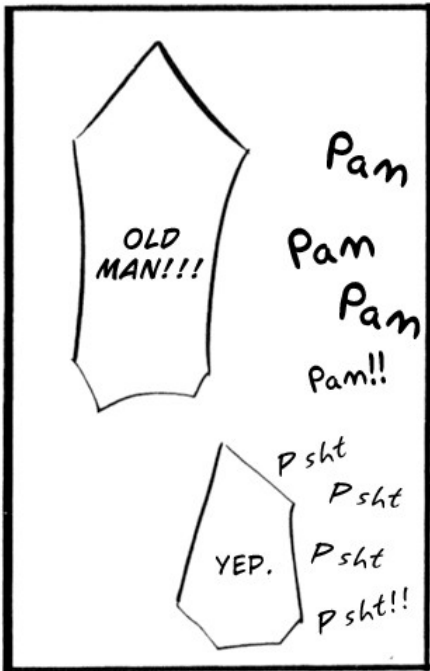
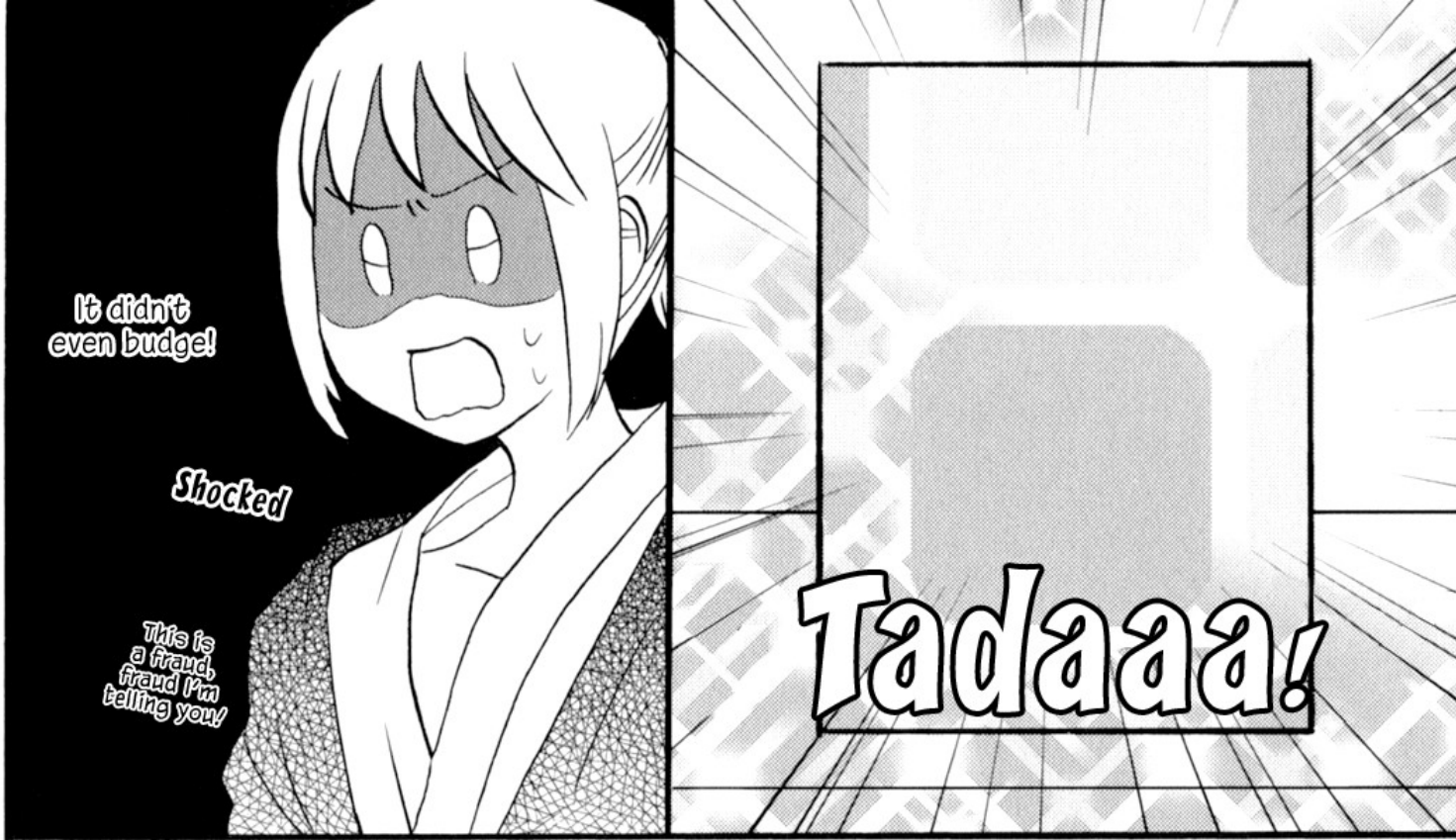



Whyyyy!?

IRRITATED



Screw it, I'm getting on this thing!

What is this?

Is it telling me we can't make up!?

Slide



Lift



THANKS.

place

EXCUSE ME, ONE ROUND PLEASE.



!!!



**Pa-clank!**



**Thump**

...Tami!?



IT'S JUST  
LUCK.

WHOA, YOU'RE  
GOOD, MISS!

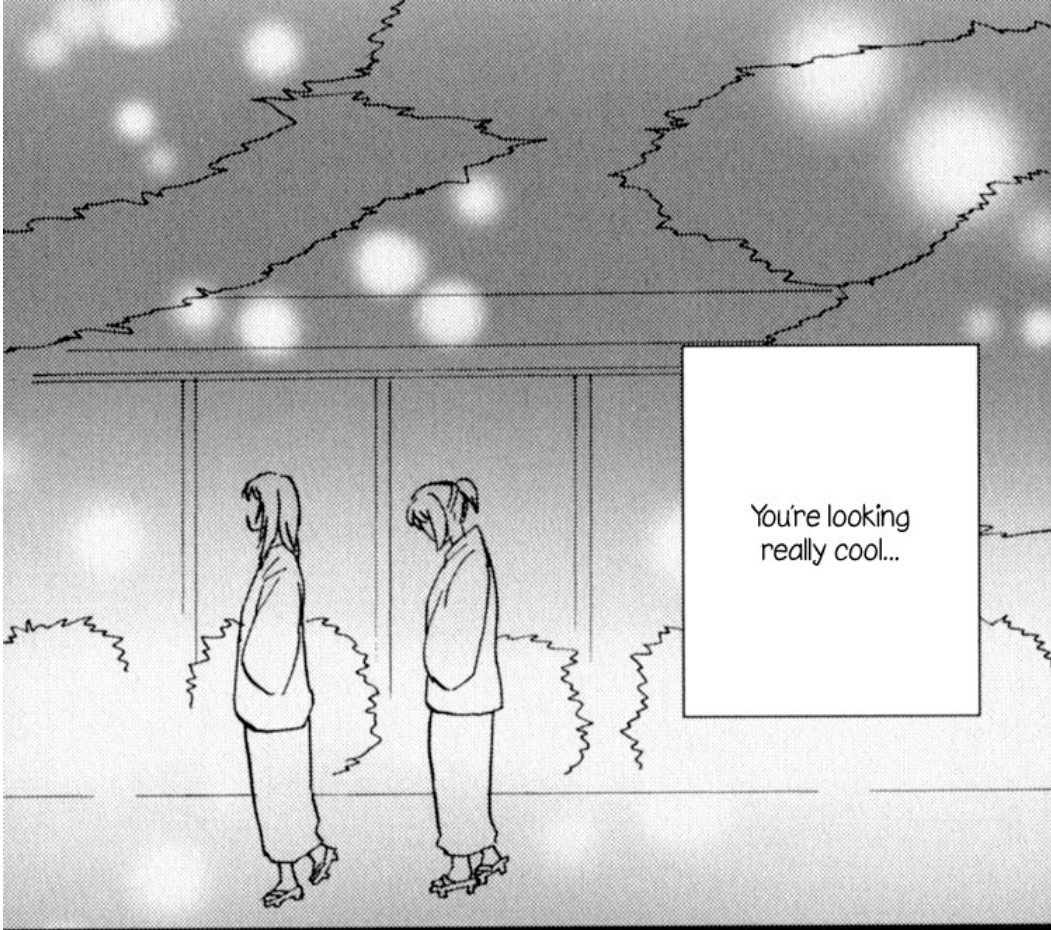

You're looking  
really cool...

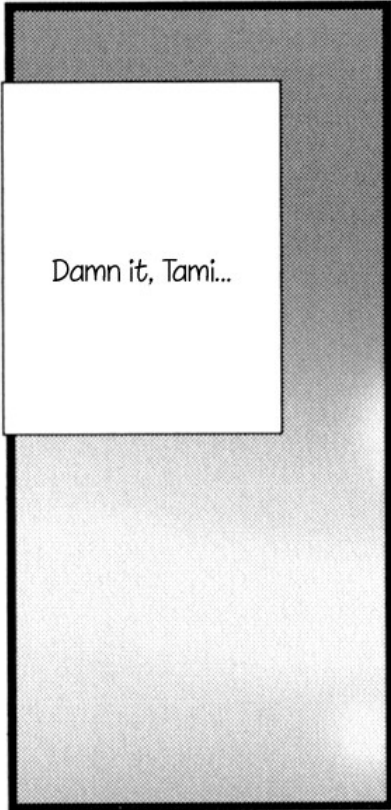

Damn it, Tami...



WHAT?

Grip



WAKABA...



HUH?

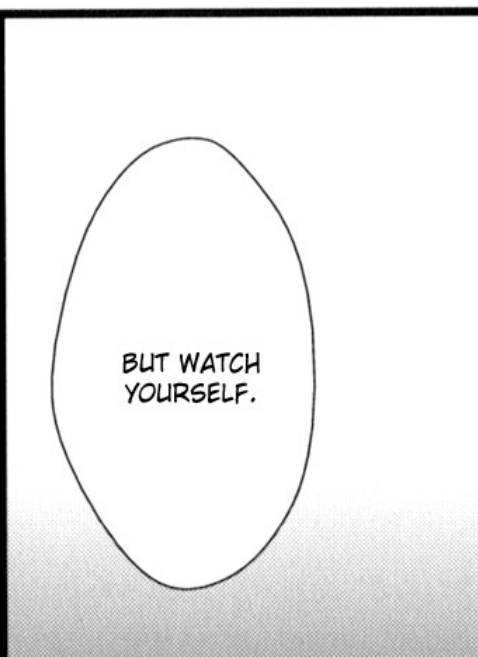

BUT WATCH  
YOURSELF.



I UNDERSTAND  
THAT YOU  
WERE HAVING  
FUN OVER  
THERE...



SORRY, I'LL BE MORE CAREFUL.

TO BE HONEST, I DON'T WANT ANYONE ELSE TO SEE...

OKAY...

What are you smiling for? I'm mad at you, you know!

YOU WEARING A YUKATA, WAKABA.

YEAH.

IT'S BEEN A WHILE SINCE WE'VE HELD HANDS.

LOOK, WAKABA.

OH, HEY.



Looking at this beautiful moon...

Ahh... You know...



HEY, TAMI...

I feel like I can be honest.



...AH...



HM?



IDIOT!

WHAT'S THIS YOU'RE WEARING? WERE YOU EXPECTING THIS?



WELL, IT'S THE FIRST TIME WE'VE DONE IT IN YUKATA.

Please excuse me.

Tug



WHY DID YOU STOP ALL OF THE SUDDEN?

WHAT?

Half naked...



BLUSH

Where are you talking to!?



Churp

H-HEY... AH...M... I SAID...

AHN... I SAID NO...



Lift

I CAN'T?



...HM ...?



NO... YOU...

CAN...!

Squeeze

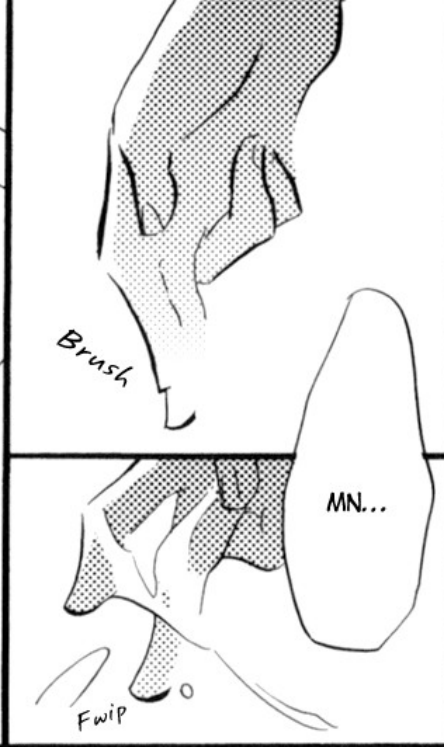

Brush

MN...

Fwip

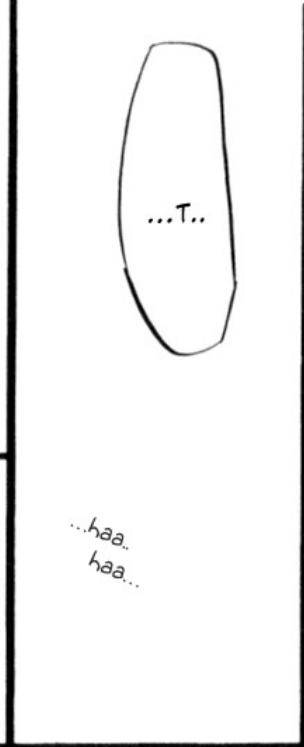

...T...

...haa... haa...

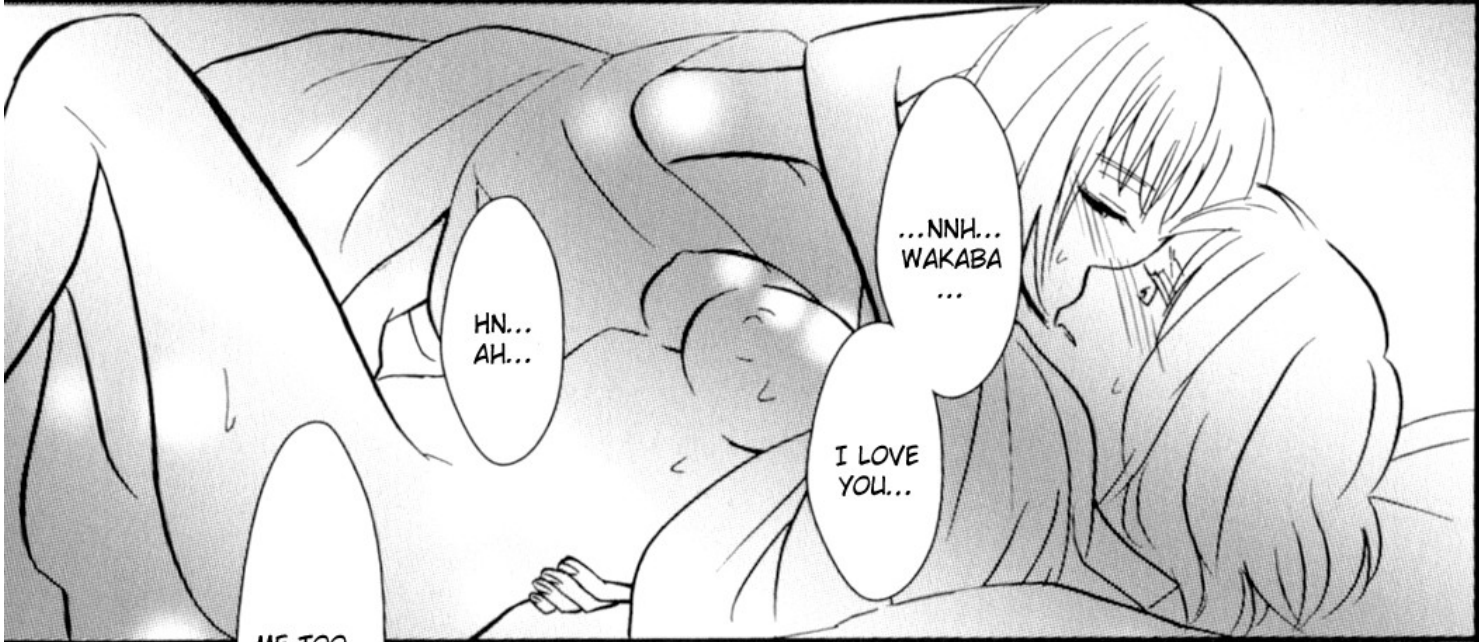

HN... AH...

ME TOO...

...NNH... WAKABA ...

I LOVE YOU...



The prize from the game.

EH? I HAVE NO IDEA.

WHAT'S IN THIS THING?



CAN I TRY OPENING IT?



BY THE WAY...

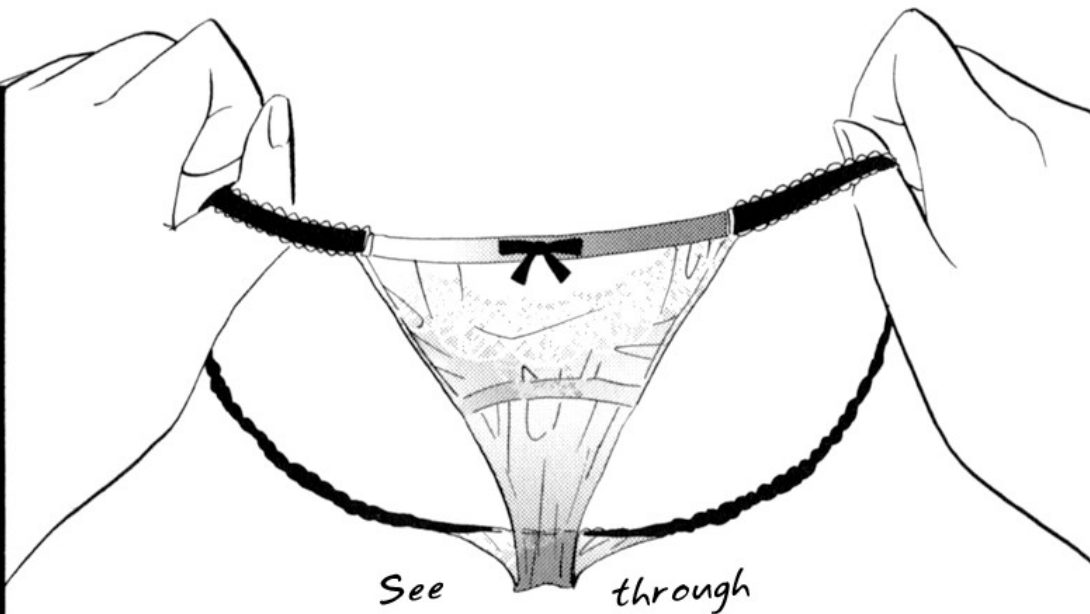

Flip ♡



Tranquil Spring and Payapaya Scans present...



Yukemuri Sanctuary - Chapter 05

Raws: Audio Erotica

Translator : Hitsuji-san

Proofreader : Babelglyph

Editor: Kite

Quality Checkers: Audio Erotica

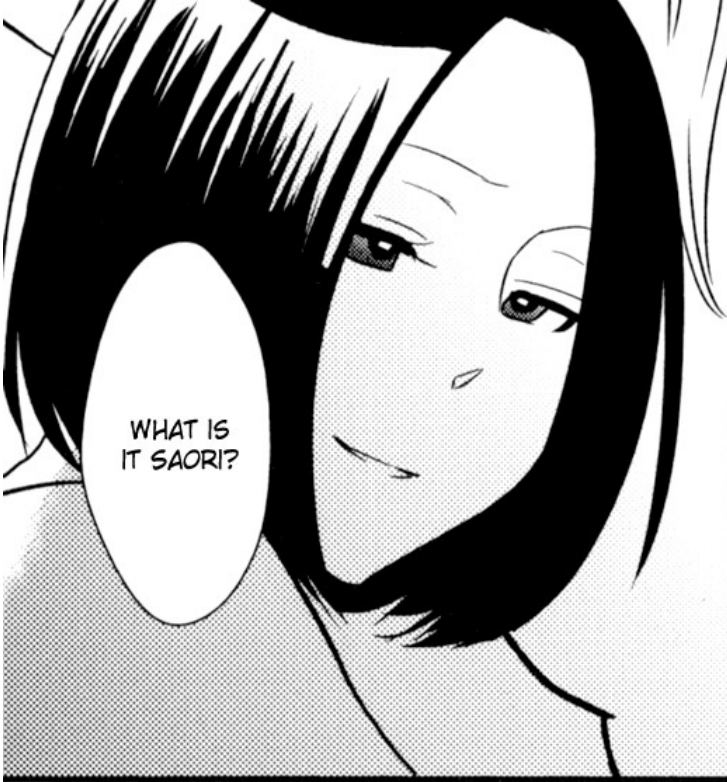

WHAT IS IT SAORI?

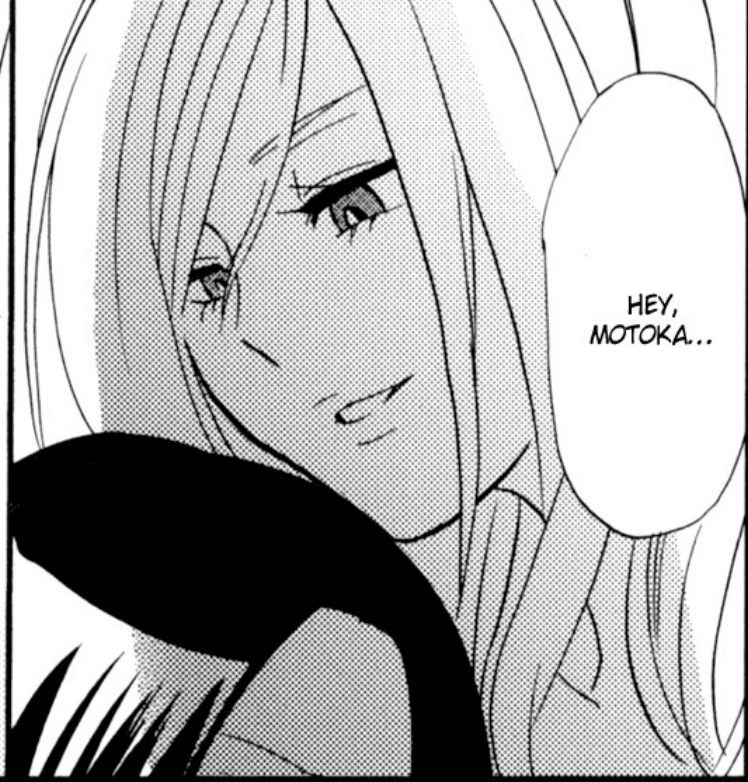

HEY, MOTOKA...

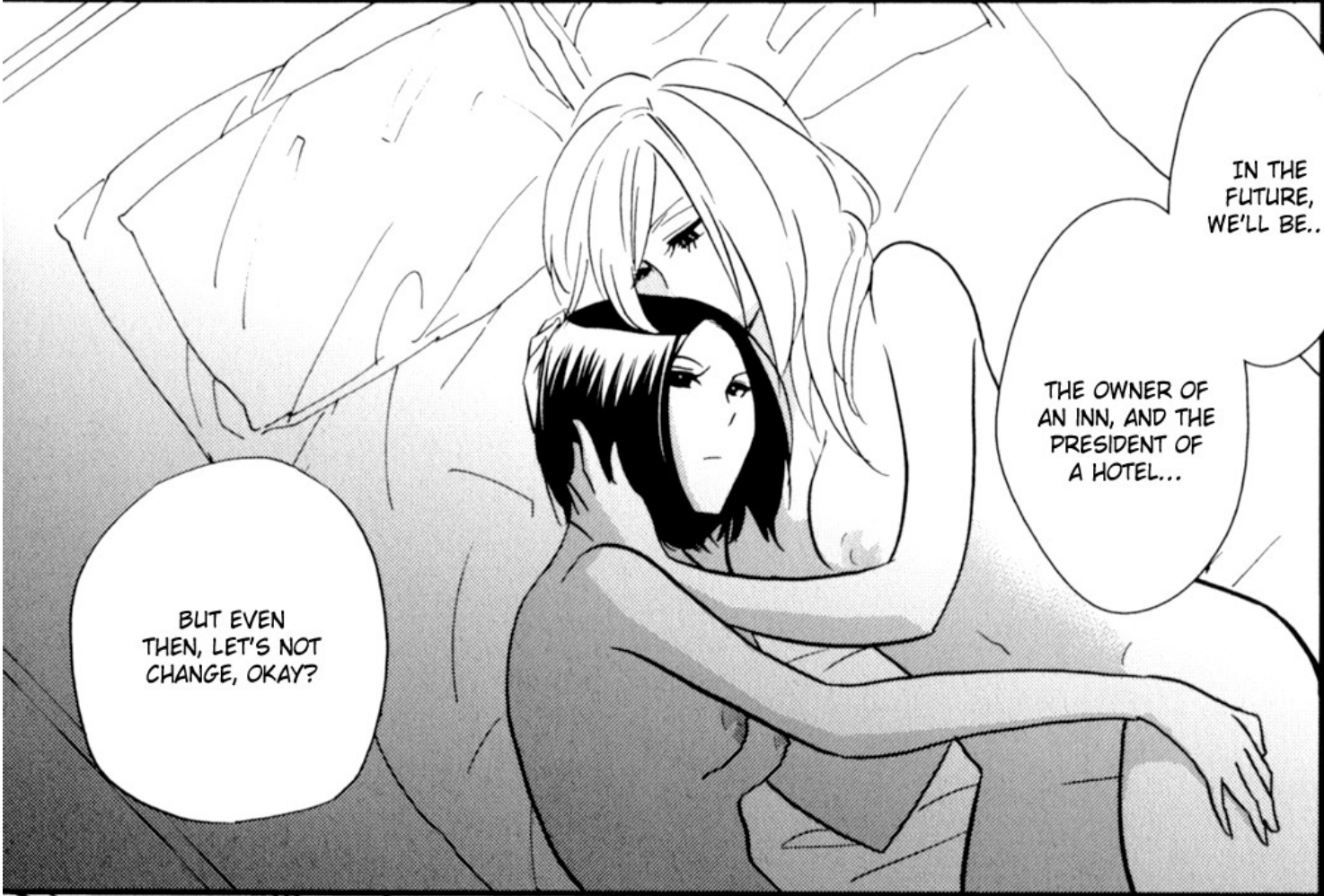

IN THE FUTURE, WE'LL BE...

THE OWNER OF AN INN, AND THE PRESIDENT OF A HOTEL...

BUT EVEN THEN, LET'S NOT CHANGE, OKAY?

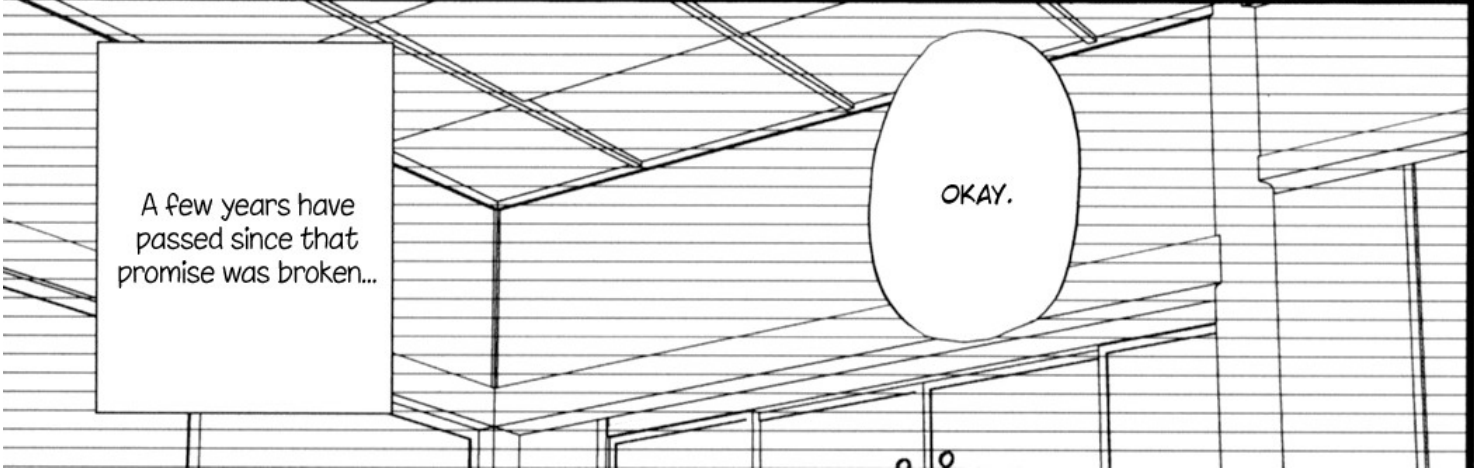

A few years have passed since that promise was broken...

OKAY.

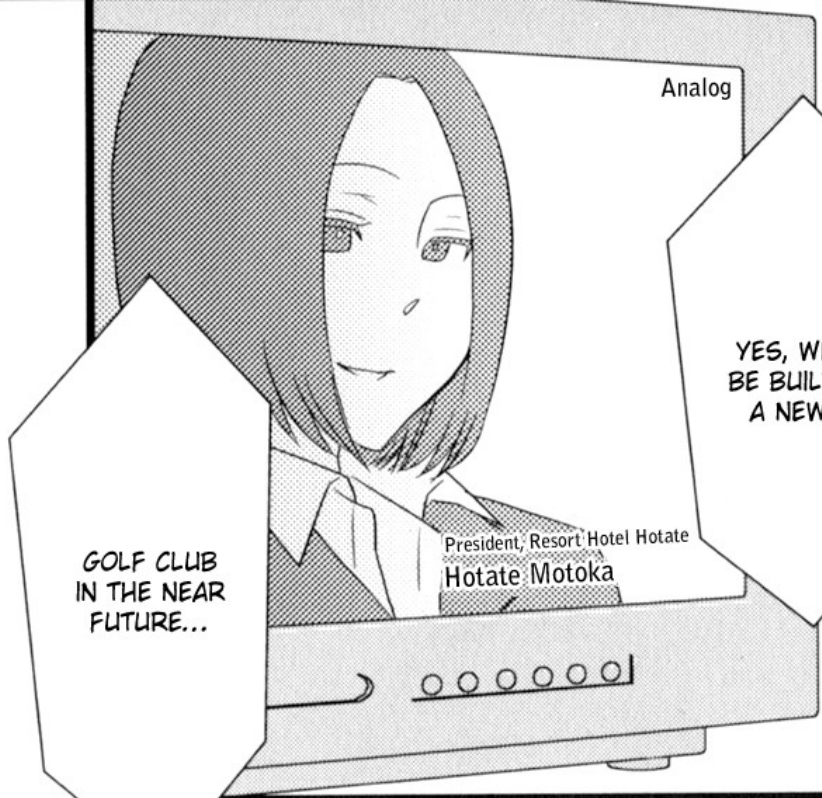

YES, WE'LL BE BUILDING A NEW...

GOLF CLUB IN THE NEAR FUTURE...

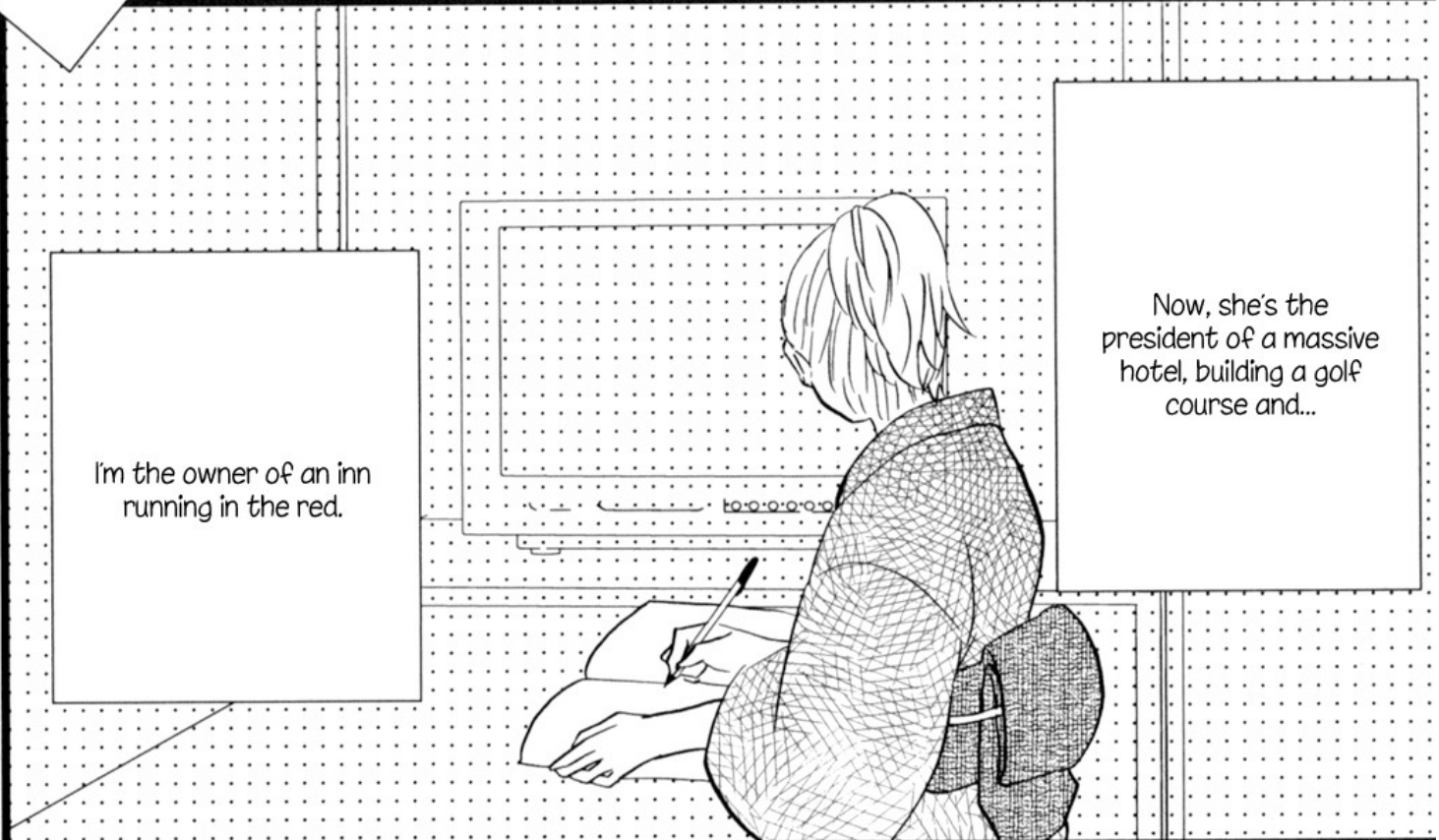

I'm the owner of an inn running in the red.

Now, she's the president of a massive hotel, building a golf course and...



I NEED TO WORK HARDER!

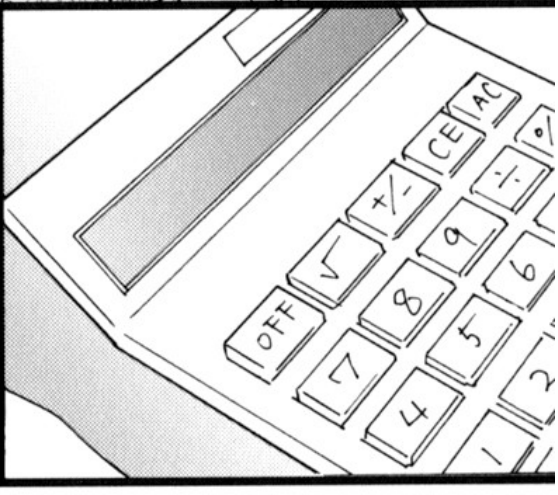



☪ Sixth Night ☪

Young Inn Owner Travels Through Her First Love Part 1



YAAAY!!!

Banquet Hall

IT'S ALMOST TIME FOR THE ANNUAL ONIYURI FESTIVAL!

Yeaah!

THIS YEAR, WE'LL START ON JUNE 9TH!

Oniyuri Festival Planning Committee Conference Room

**BAM!**

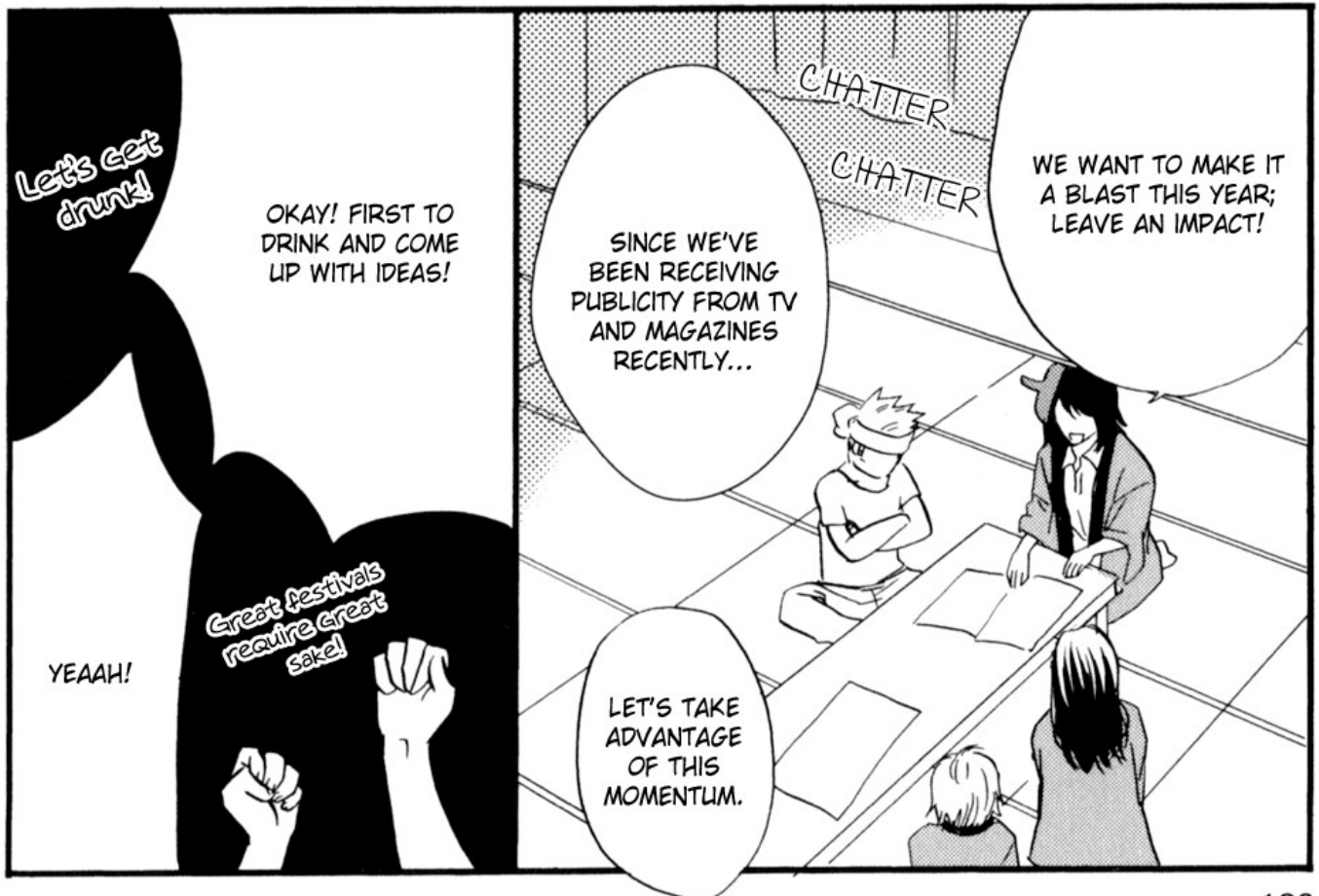

Let's get drunk!

OKAY! FIRST TO DRINK AND COME UP WITH IDEAS!

SINCE WE'VE BEEN RECEIVING PUBLICITY FROM TV AND MAGAZINES RECENTLY...

WE WANT TO MAKE IT A BLAST THIS YEAR; LEAVE AN IMPACT!

CHATTER CHATTER

YEAHH!

Great festivals require great sake!

LET'S TAKE ADVANTAGE OF THIS MOMENTUM.



OH, THESE PEOPLE...

Don't grow up to be like them, lochan. ♡

I won't...



Dead drunk

...YEAH...

- Oniyuri Festival Event Plans
- Nudist Onsen
  - Beautiful Breast Contest (Beautiful Butt too?)
  - Penis Performance Review
  - Boob Water Balloon Fishing
  - My Secret Spring Bragging Contest
  - Speed Stripping Competition
  - Wakame Sake Dancing
  - Old and young, male and nyotaimori

ANYWAY, THESE PLANS... ALL SOUND LIKE SOMETHING THAT'LL END UP INVOLVING THE POLICE.

I think we should consider this their positive trait.



GETTING DRUNK AT SUCH AN EARLY HOUR, HOW NICE.



THUMP



Slide

...SEEMS EVERYONE IS ENJOYING THEMSELVES.

\*Wakamezake - Literally seaweed sake. An act in which a woman sits folding their legs underneath their thighs and leans back, creating a "cup" between their thighs and lower stomach where sake is poured into and drunk from.

\*Nyotaimori- Literally female body presentation. Act in which woman's body is stacked with food such as Sashimi and Sushi to be eaten from. In this case it's male and female body presentation.



Motoka...

BA-DUM

OH, ISN'T THAT THE PRESIDENT OF HOTEL HOTATE?

I SAW HER ON TV FEW DAYS AGO.

HUH...

I heard their spa's really nice, let's go someday.

Mmm.

CHATTER

IT'LL BE A BIG HELP IF HOTEL HOTATE IS WILLING TO.

MAYBE SHE'S GOING TO HELP OUT WITH OUR FESTIVAL?

I WONDER WHAT SHE WANTS?

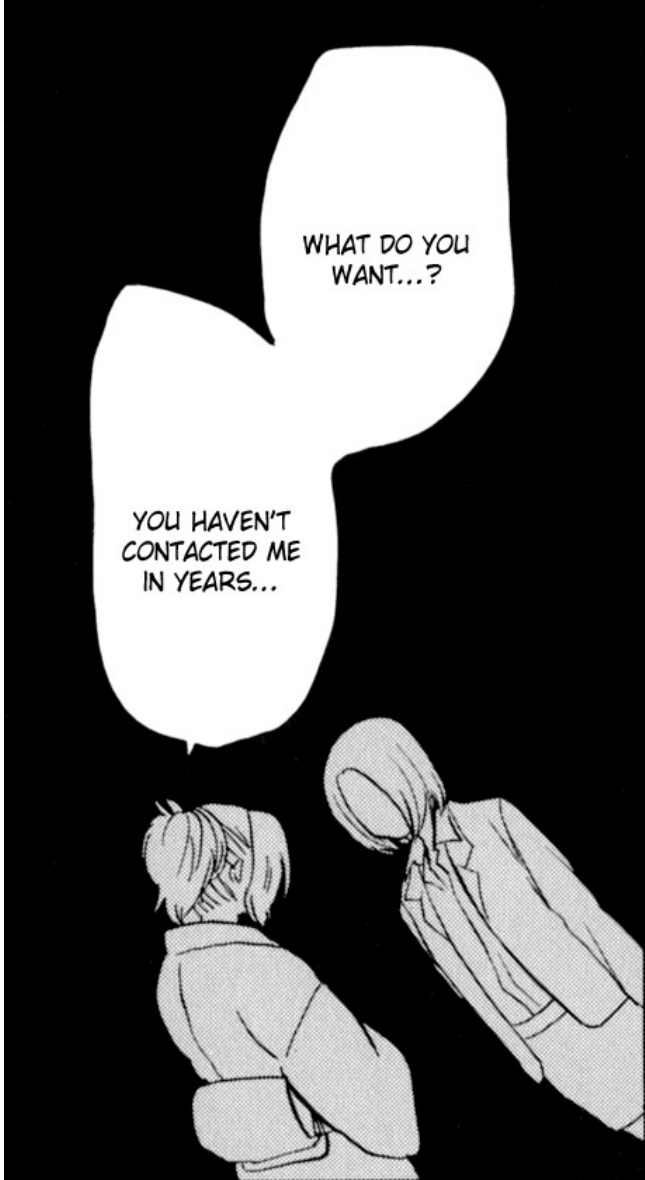

WHAT DO YOU WANT...?

YOU HAVEN'T CONTACTED ME IN YEARS...

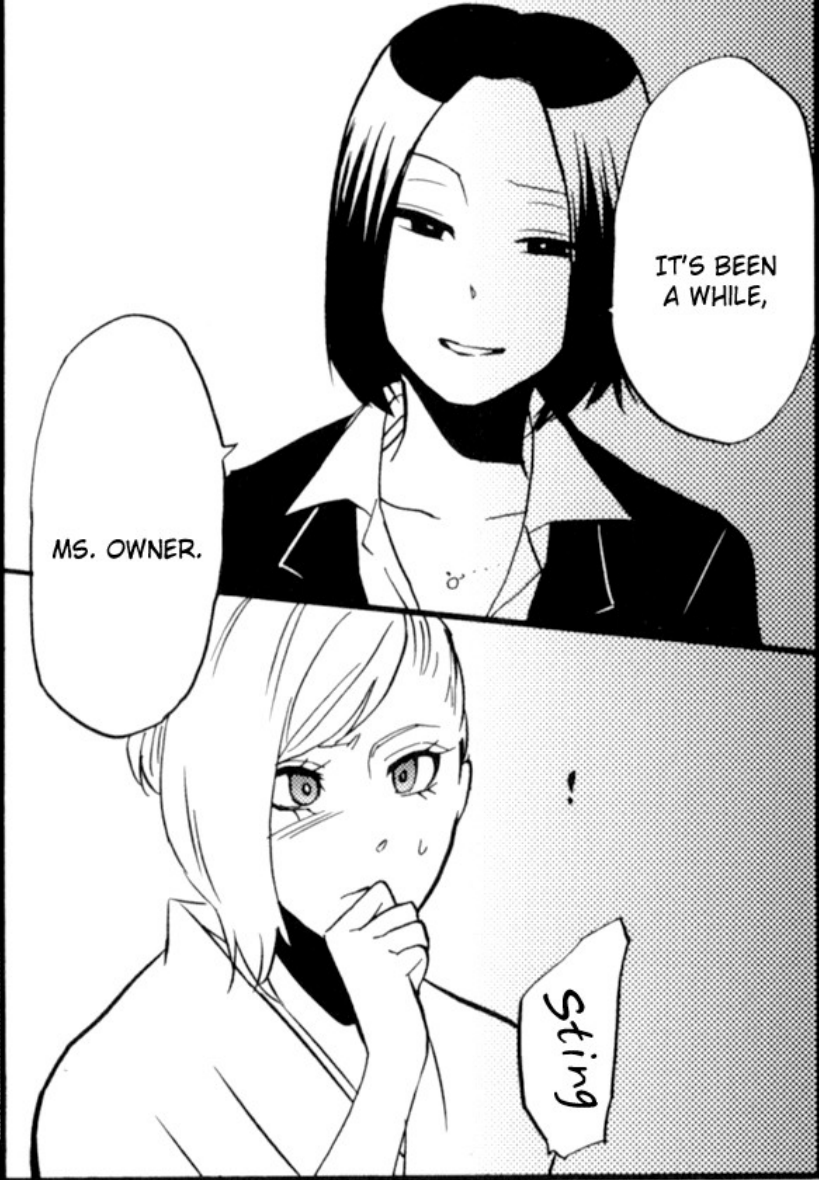

IT'S BEEN A WHILE,

MS. OWNER.

Sting



Heh



I HAVE AN ANNOUNCEMENT FOR EVERYONE.

Us?

Drowsy o

hmm?



TODAY,

WHAT!?

WH-

AND MAKING IT INTO  
A GOLF COURSE.

OUR COMPANY  
WILL BE BUYING  
THIS WHOLE HOT  
SPRINGS AREA,

!?

Thump

The plan she  
was talking  
about on  
TV... so this  
is what she  
meant...

Thump

I'LL LEAVE FOR TODAY.

Well, have fun.

HOW UN-SIGHTLY. THIS CONVERSATION IS GOING NOWHERE.

YER OUT OF YER MIND YA BASSSTARD! GO SSHOVE A @#%\*~!

Nyowaaa!

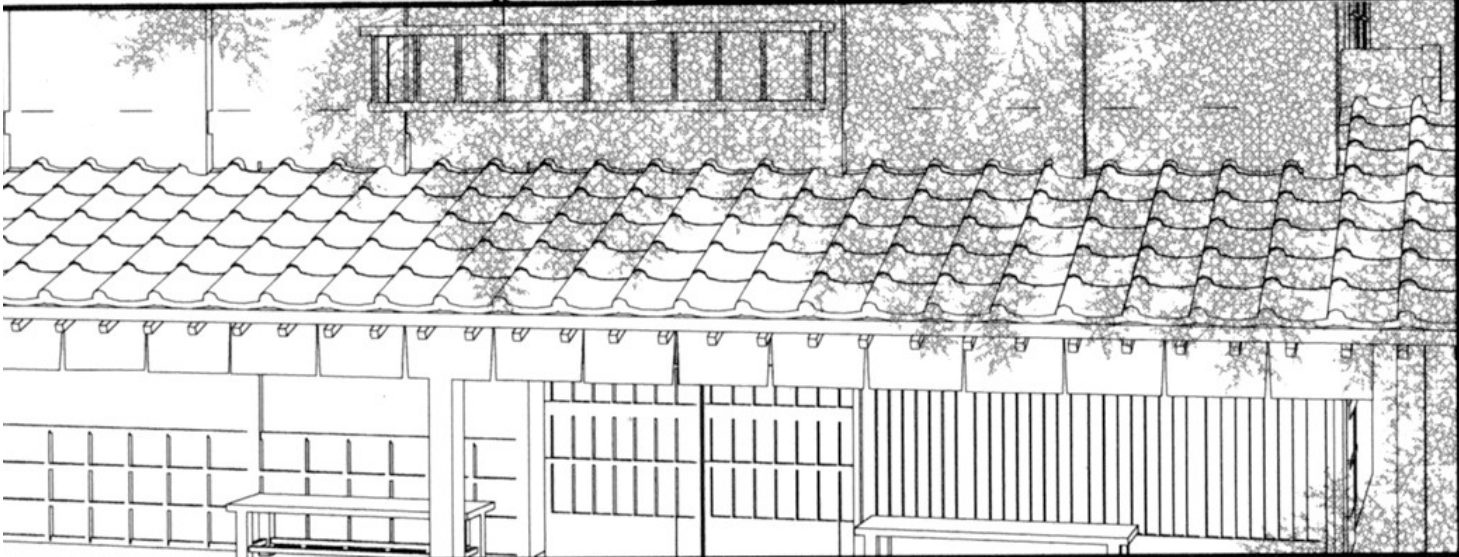

THERE'S SOMETHING I WOULD LIKE TO DISCUSS ONLY WITH YOU, MS. OWNER.

OH, ONE MORE THING.

YOU'VE CHANGED, MOTOKA...

IT'S ONLY NATURAL THAT THINGS CHANGE.

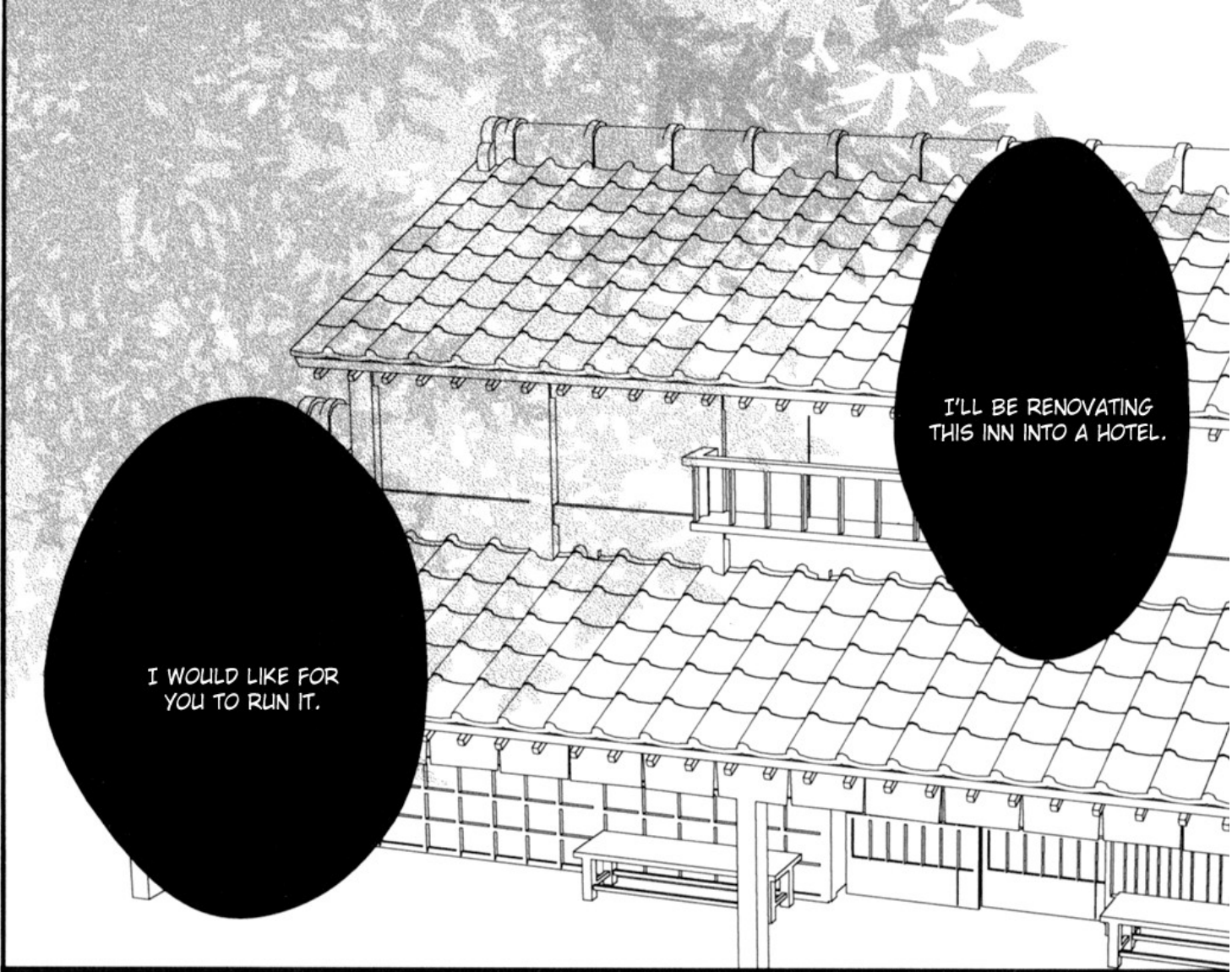

I WOULD LIKE FOR YOU TO RUN IT.

I'LL BE RENOVATING THIS INN INTO A HOTEL.

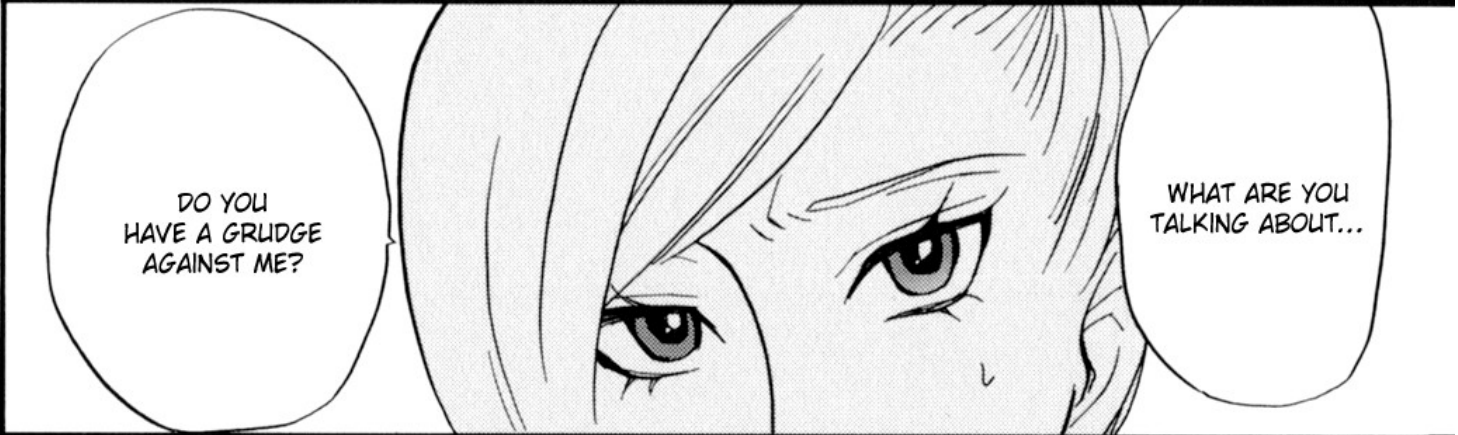

DO YOU HAVE A GRUDGE AGAINST ME?

WHAT ARE YOU TALKING ABOUT...

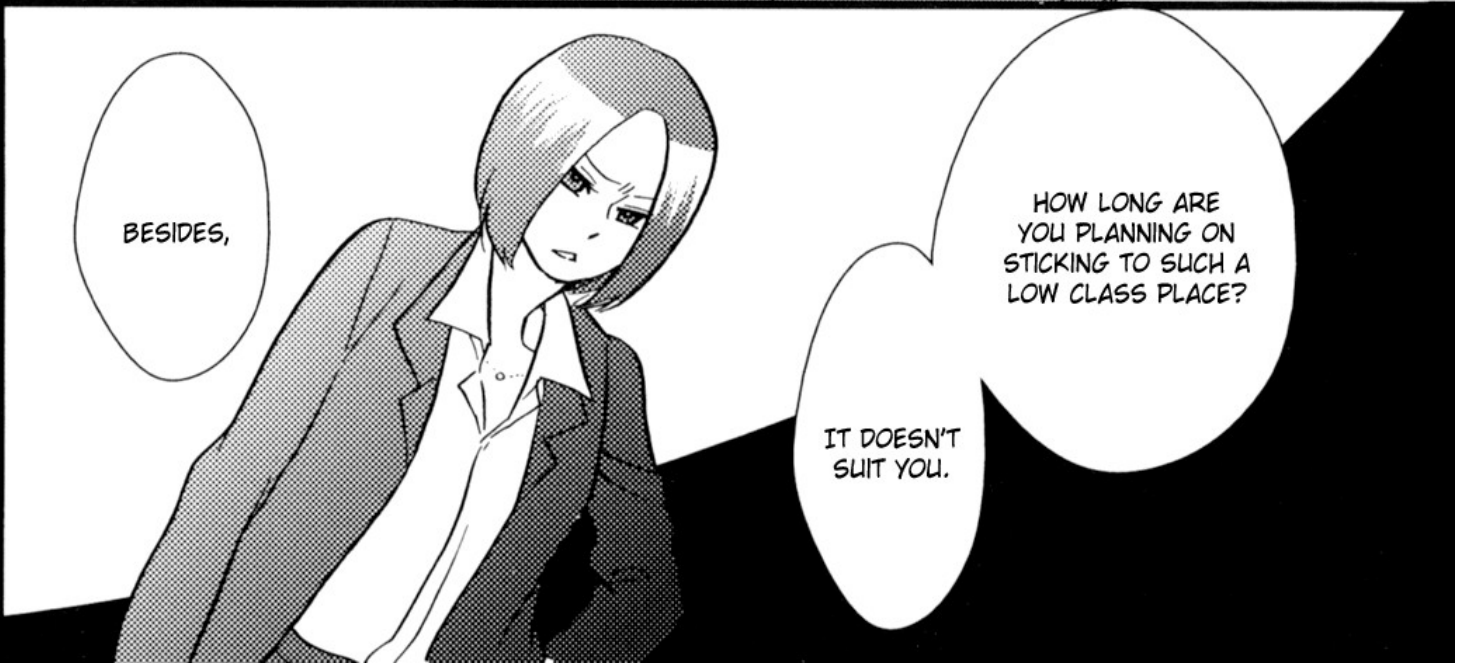

BESIDES,

IT DOESN'T SUIT YOU.

HOW LONG ARE YOU PLANNING ON STICKING TO SUCH A LOW CLASS PLACE?

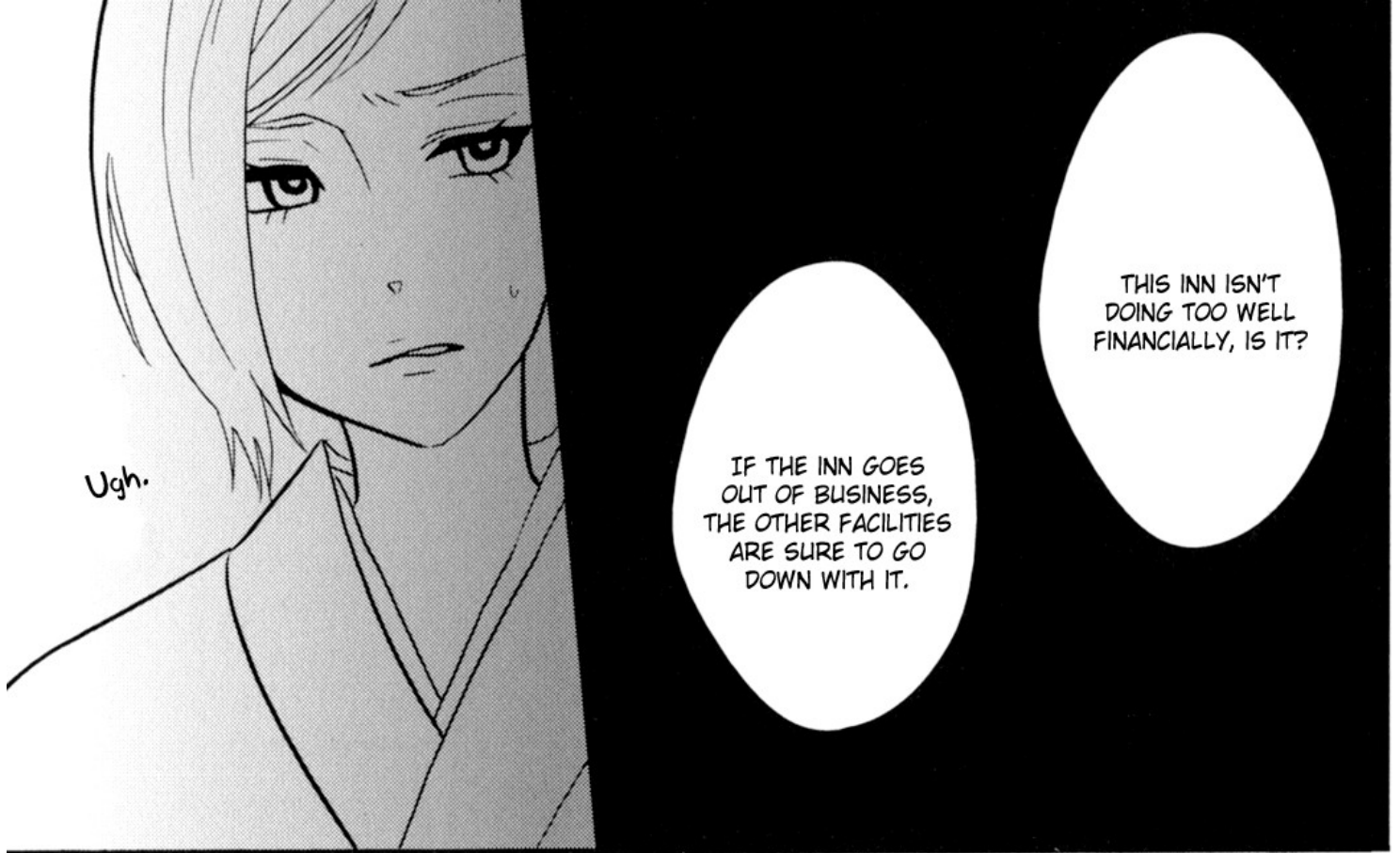

Ugh.

IF THE INN GOES  
OUT OF BUSINESS,  
THE OTHER FACILITIES  
ARE SURE TO GO  
DOWN WITH IT.

THIS INN ISN'T  
DOING TOO WELL  
FINANCIALLY, IS IT?

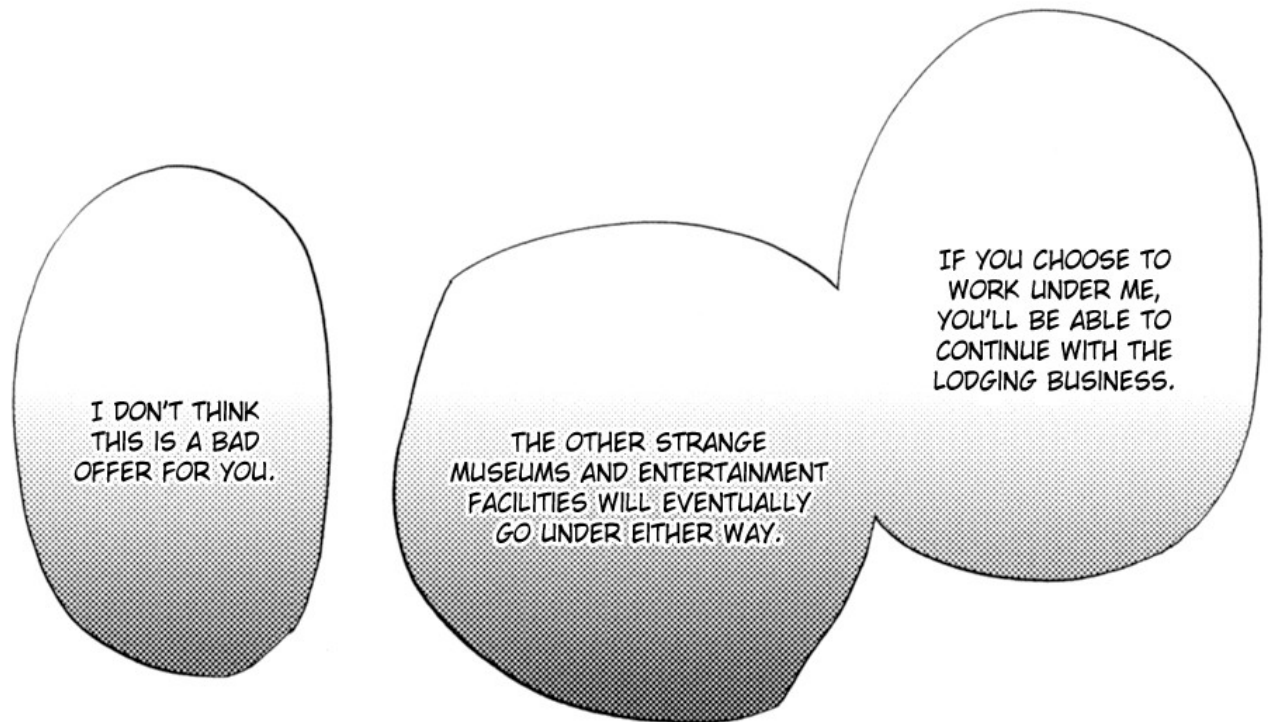

I DON'T THINK  
THIS IS A BAD  
OFFER FOR YOU.

THE OTHER STRANGE  
MUSEUMS AND ENTERTAINMENT  
FACILITIES WILL EVENTUALLY  
GO UNDER EITHER WAY.

IF YOU CHOOSE TO  
WORK UNDER ME,  
YOU'LL BE ABLE TO  
CONTINUE WITH THE  
LODGING BUSINESS.



I'LL BE GOING  
NOW AS I'M  
INCREDIBLY  
BUSY.

WELL  
THEN,

Please give me a  
reply by June 9th.

If I can, I would like to  
start the construction  
immediately, but...

I'll be expecting  
a positive answer  
from you.

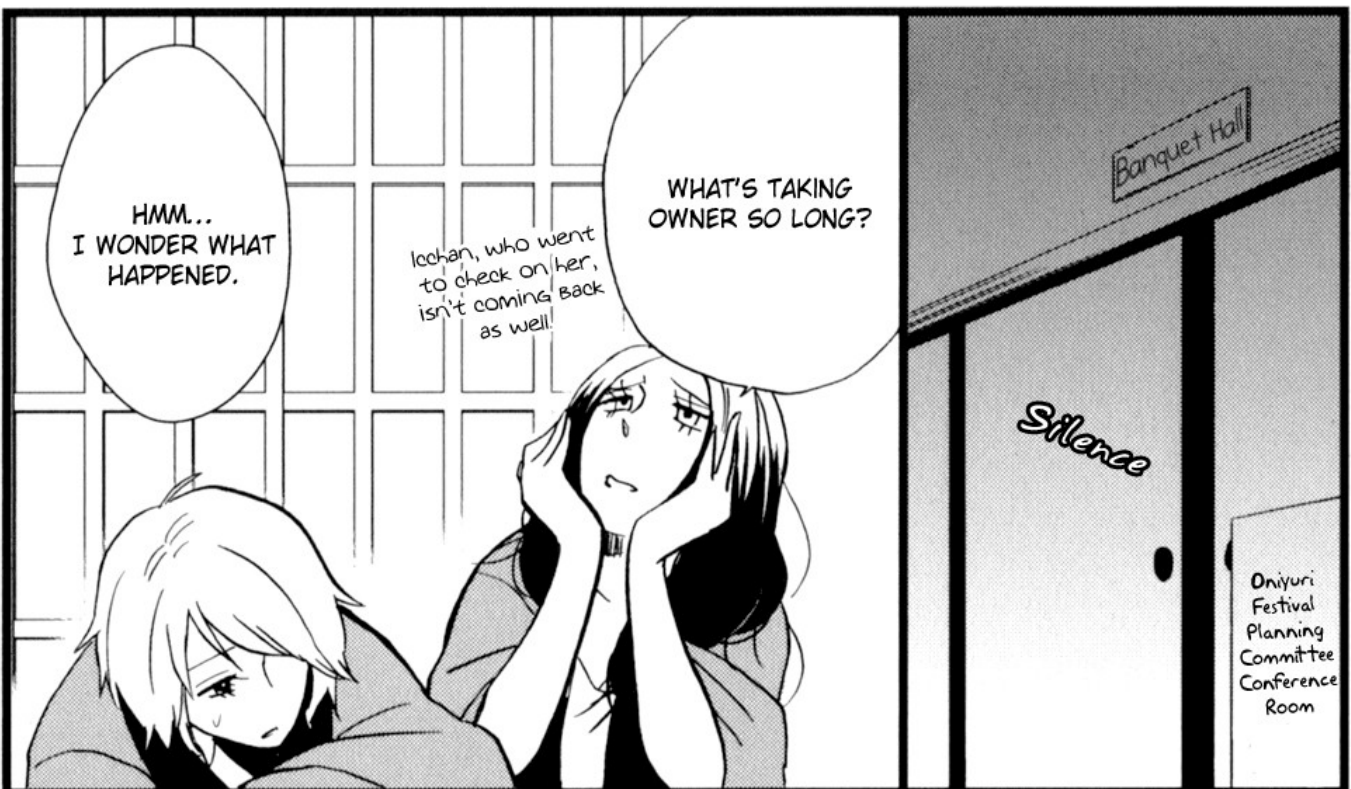
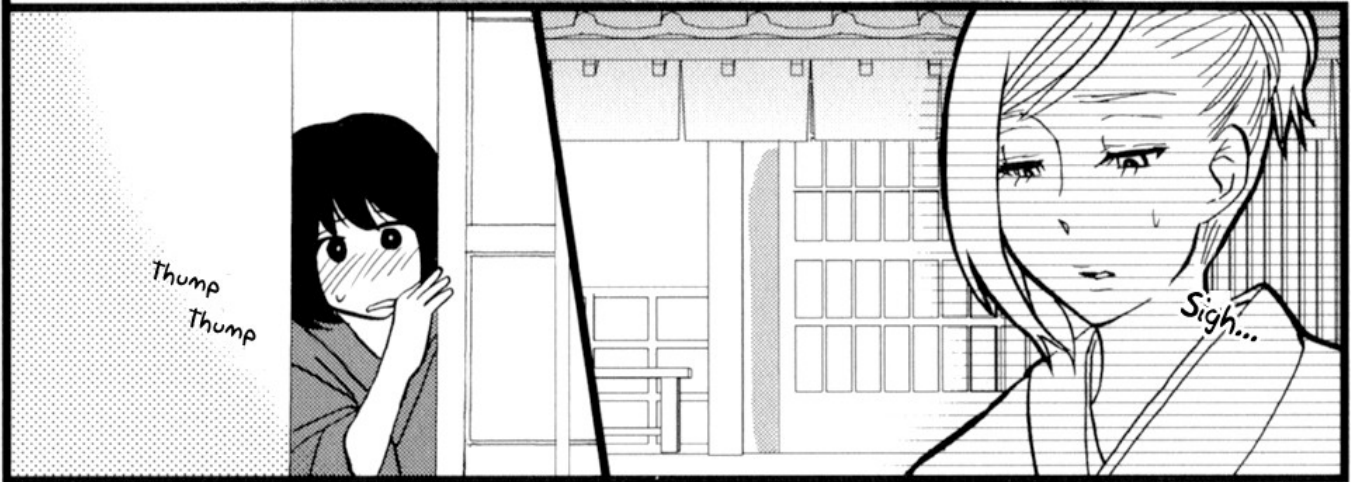



EHH, NO WAY.

SO WHAT IF THEY'RE CONSPIRING TOGETHER?

OWNER AND PRESIDENT SEEMED TO KNOW EACH OTHER...

WHAT IS?

IT'S A LITTLE WORRYING.

Good idea. ♡

Let's split Oniyuri between us!

Imagination



EHH!?

**SHOCK**

They used to have strangely erotic air to 'em.

I THINK THE TWO OF 'EM WERE A COUPLE IN THE PAST...

WELL, YA NEVER KNOW.

That's no good then!

Fwoa ♡



**BAM!**

STOP IT!



THEN THE TWO OF THEM REALLY ARE TEAMING UP,

TO TAKE OVER ONIYURI?

**CHATTER**



Oh no, she's crying!



WHAT'S GOTTEN INTO ALL OF YOU?



S-SO TRUE, SO TRUE.

Ahaha, we were ahead of ourselves. It's just our imagination.

You're terrible!

THE OWNER WOULD NEVER DO SUCH THING!



YEAHH!

They weren't doing it!

Oh, by the way, kochan. How were those were-two? They weren't doing it?

I'll make some goods!

I'll start a blog!

Each of us need to do what we can!

RIGHT NOW, WE NEED TO FOCUS ON MAKING THE FESTIVAL A SUCCESS!

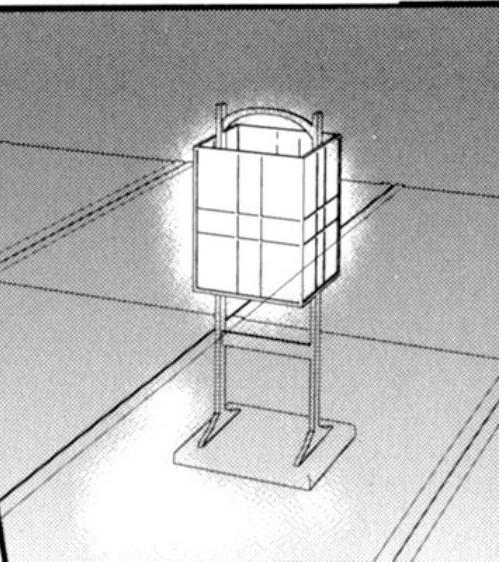
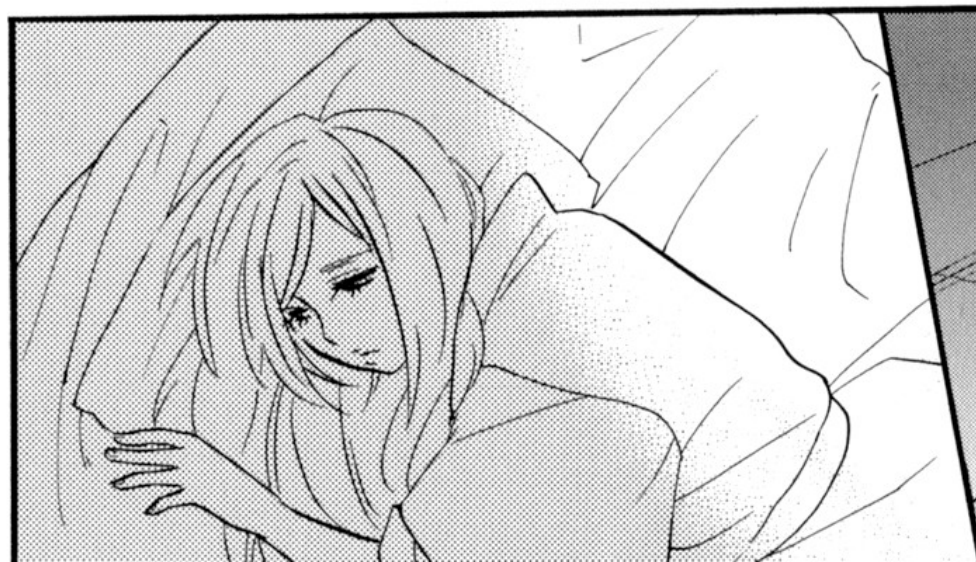



Motoka...  
what's with  
you?

We meet for the  
first time in like,  
forever and all you  
do is act strange.

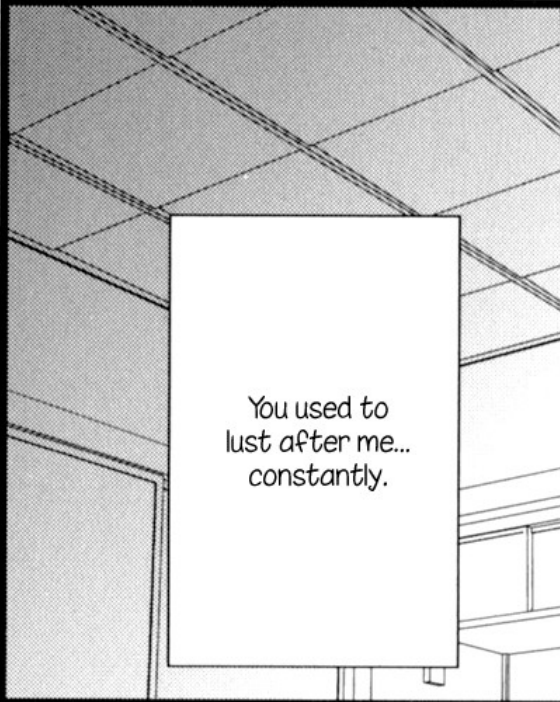

You used to  
lust after me...  
constantly.



Even when we  
parted, you just  
suddenly left  
without saying  
anything.



Yes, in this  
room, we always  
used to...

Your usual  
calm demeanor  
would burn away  
like fire with a  
single touch.

...HAH...



HAA...

AH...

Pant

Pant

Gasp

...NGH...  
HN...

MOTO...KA...

Pant

Saori...

Slide

Slick

Chrrp

AH...

Drip

HAA...

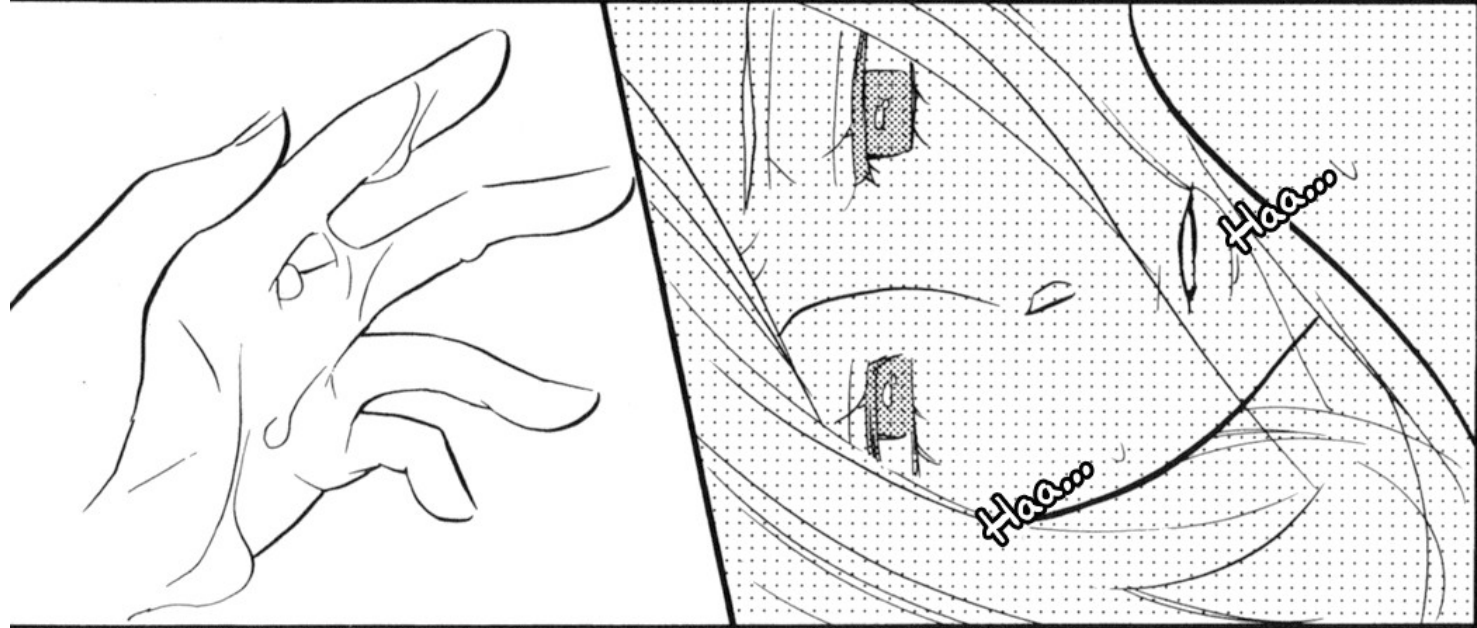
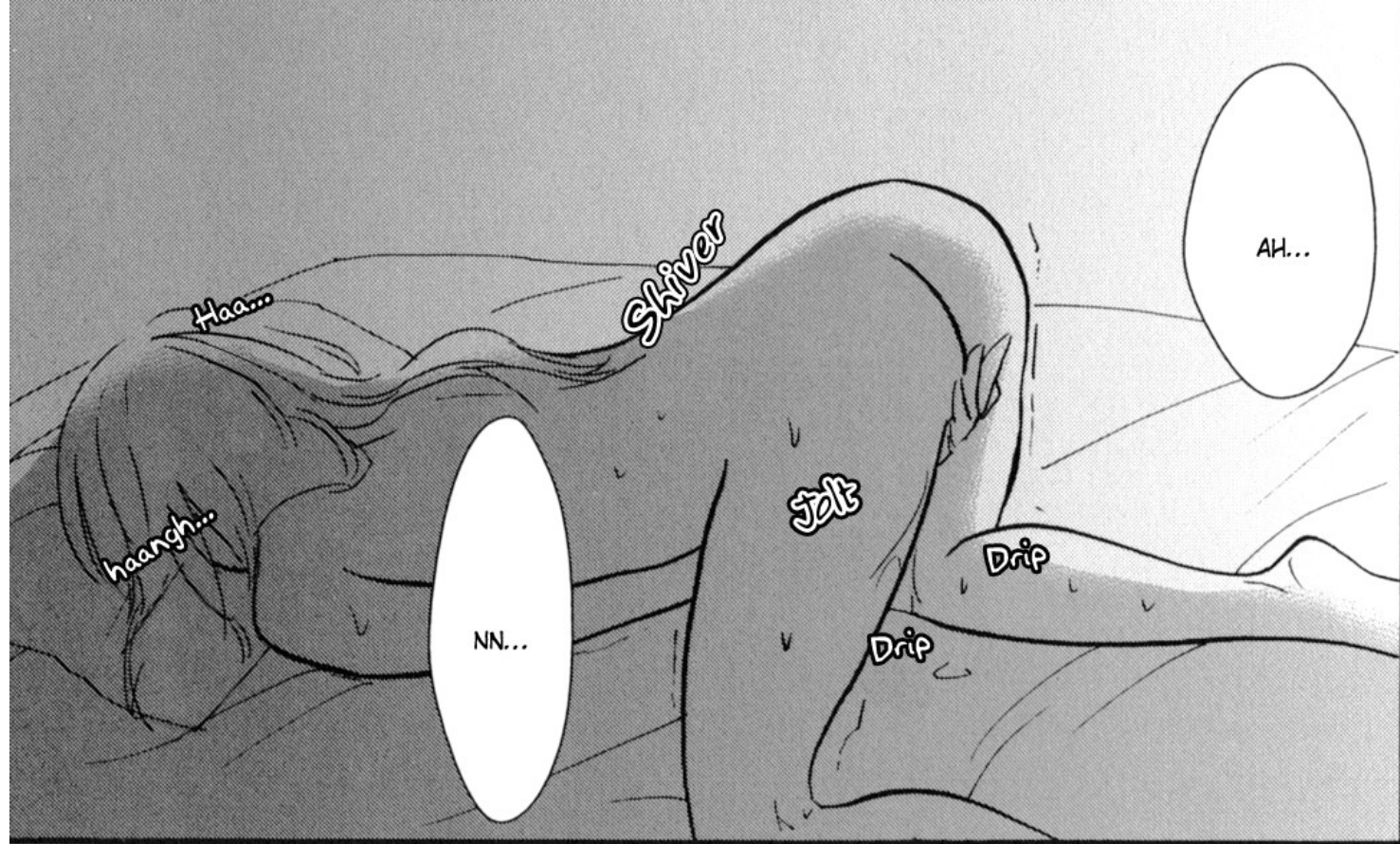

Motoka... I... still...

Motoka...



LET'S ALL DO OUR BEST TO MAKE IT A SUCCESS!

Yeaahh!!

THE FESTIVAL FINALLY BEGINS TODAY!

And then on June 9th.

Oniyuri Festival Starts Today

UM... WELL...

Ba-dump!

WHERE'S THE OWNER?

OH?

...HUH?

Head-quarters

Rustle

THE OWNER...

TROUBLE!!

HE-HEY! EVERYONE!!

DASH

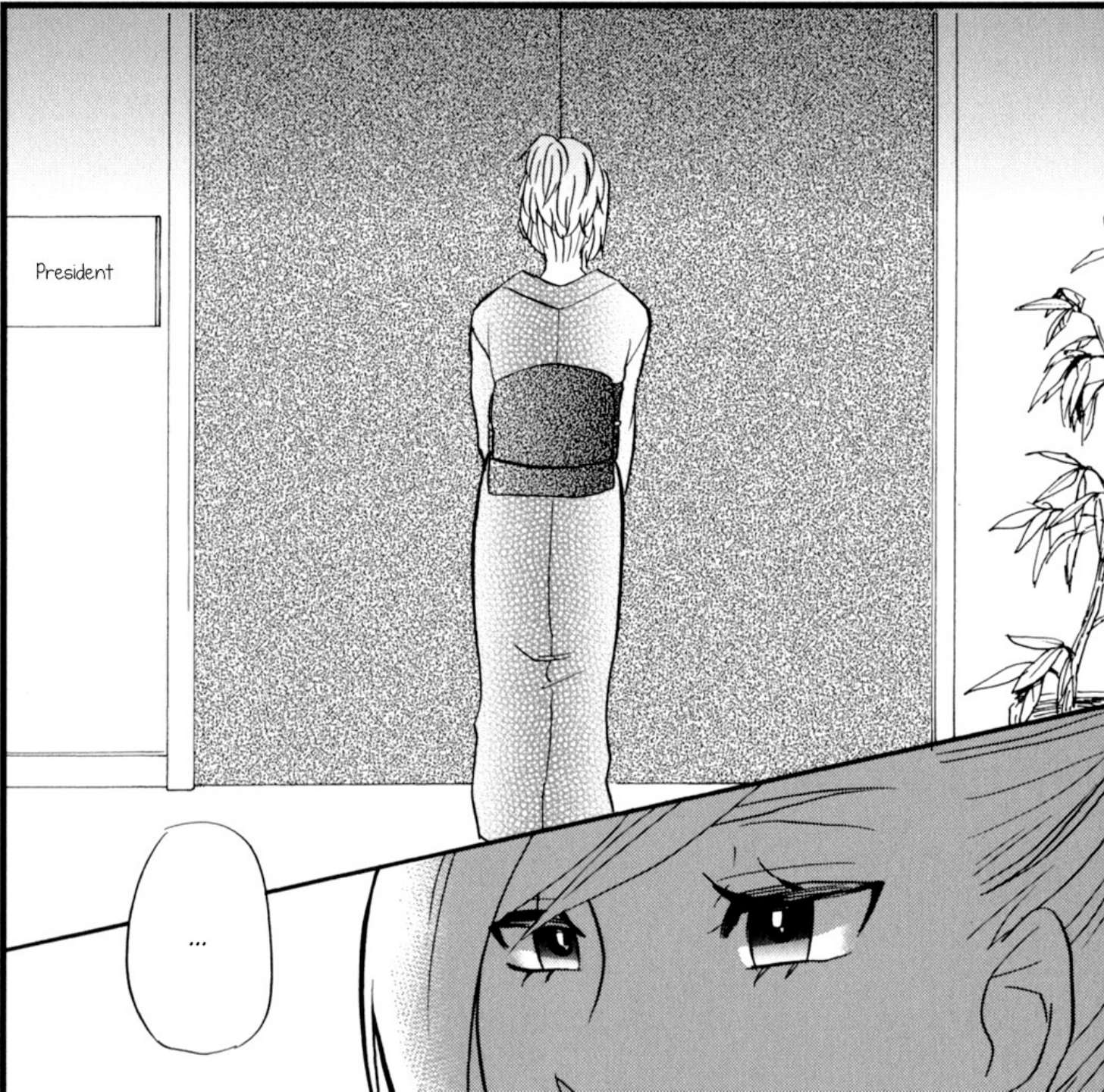
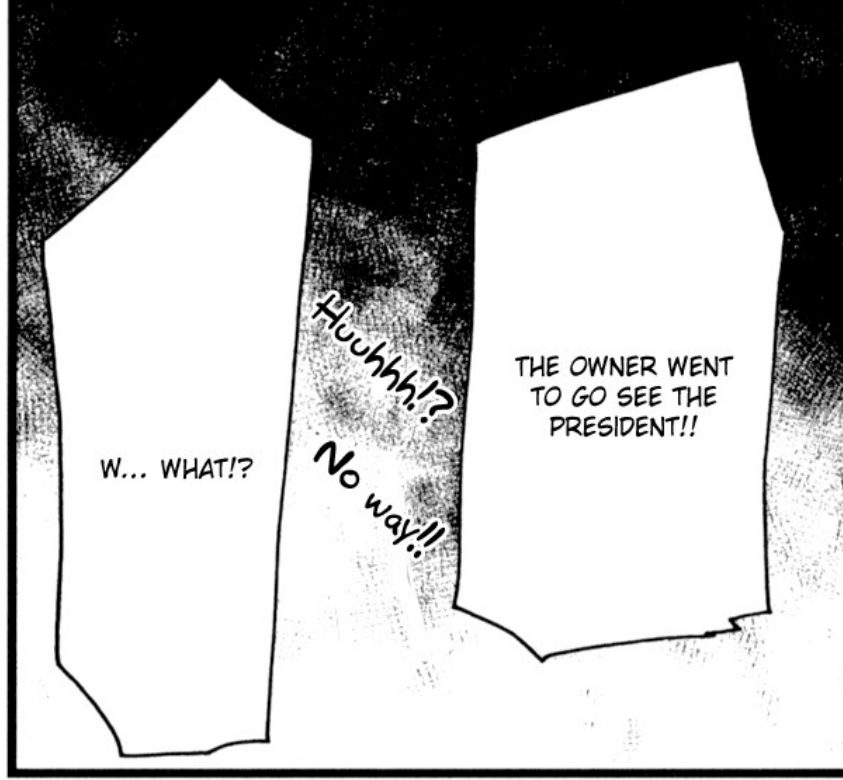
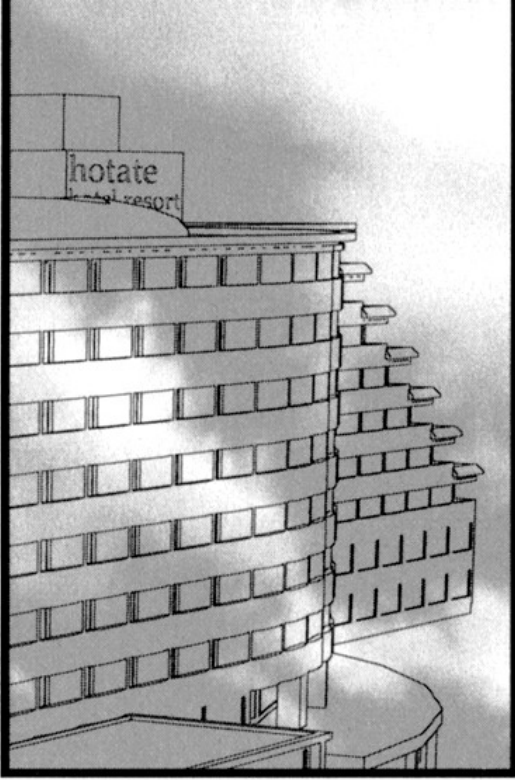



Tranquil Spring and Payapaya Scans present...

Yukemuri Sanctuary - Chapter 06

Raws : Audio Erotica  
Translator : Hitsuji-san  
Proofreader : Audio Erotica  
Editor: Kite  
Quality Checkers : Matsuri

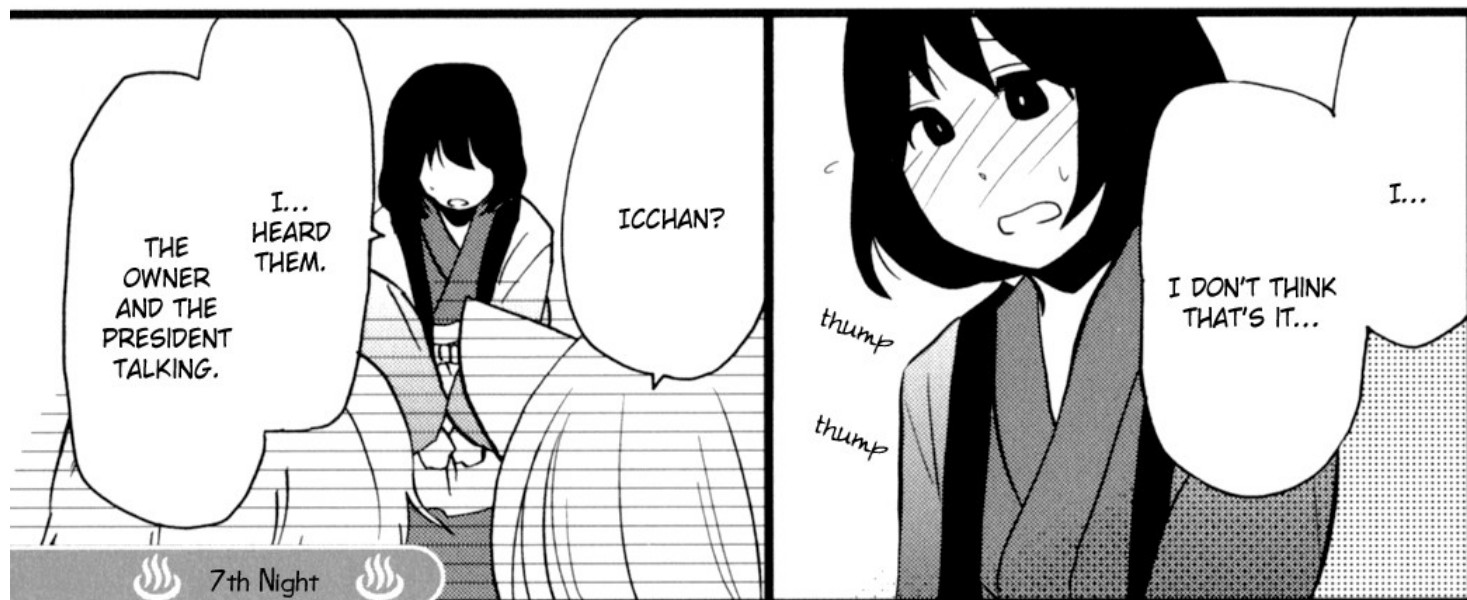
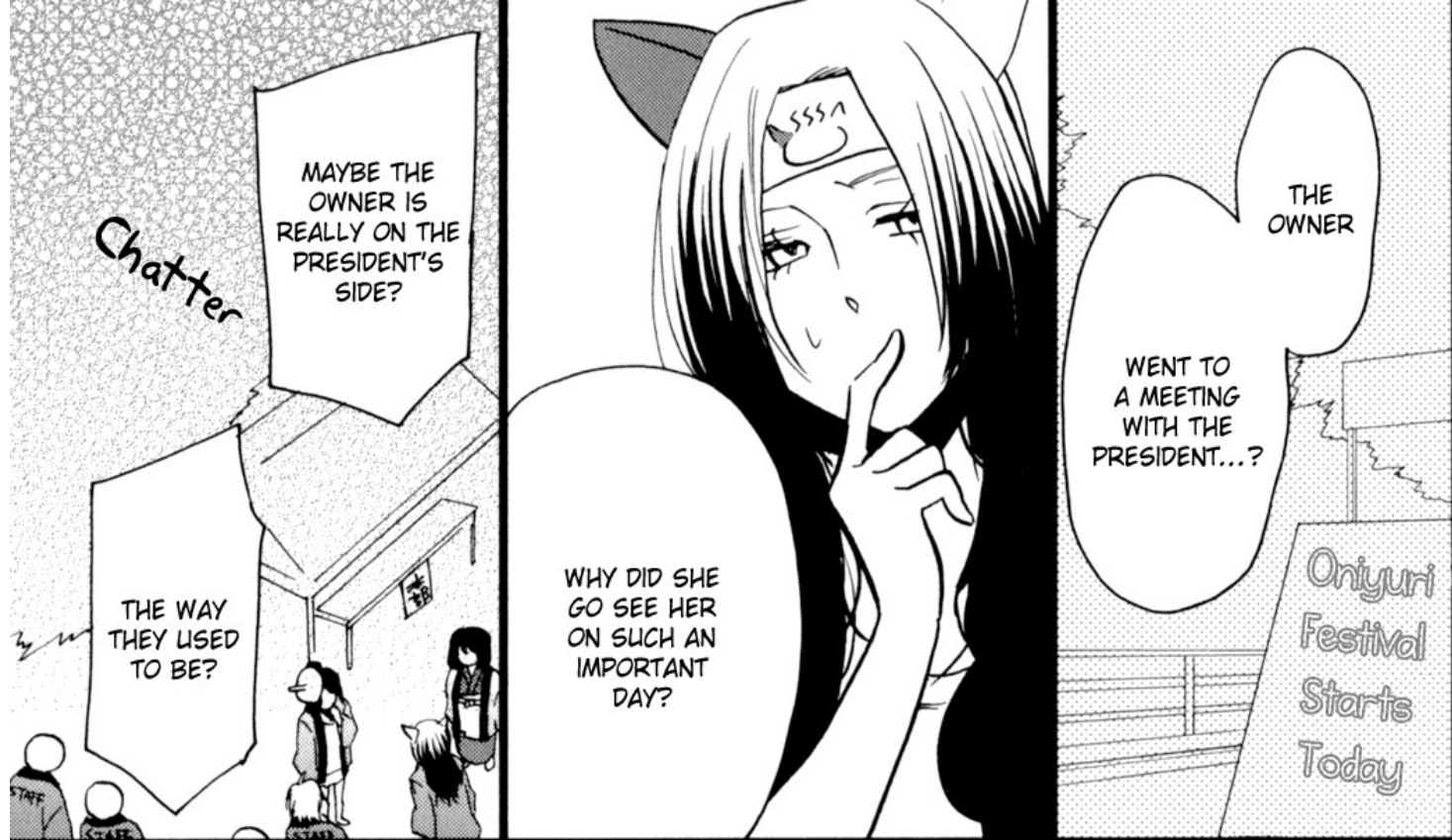

7th Night

Young Inn Owner Travels Through Her First Love Part II

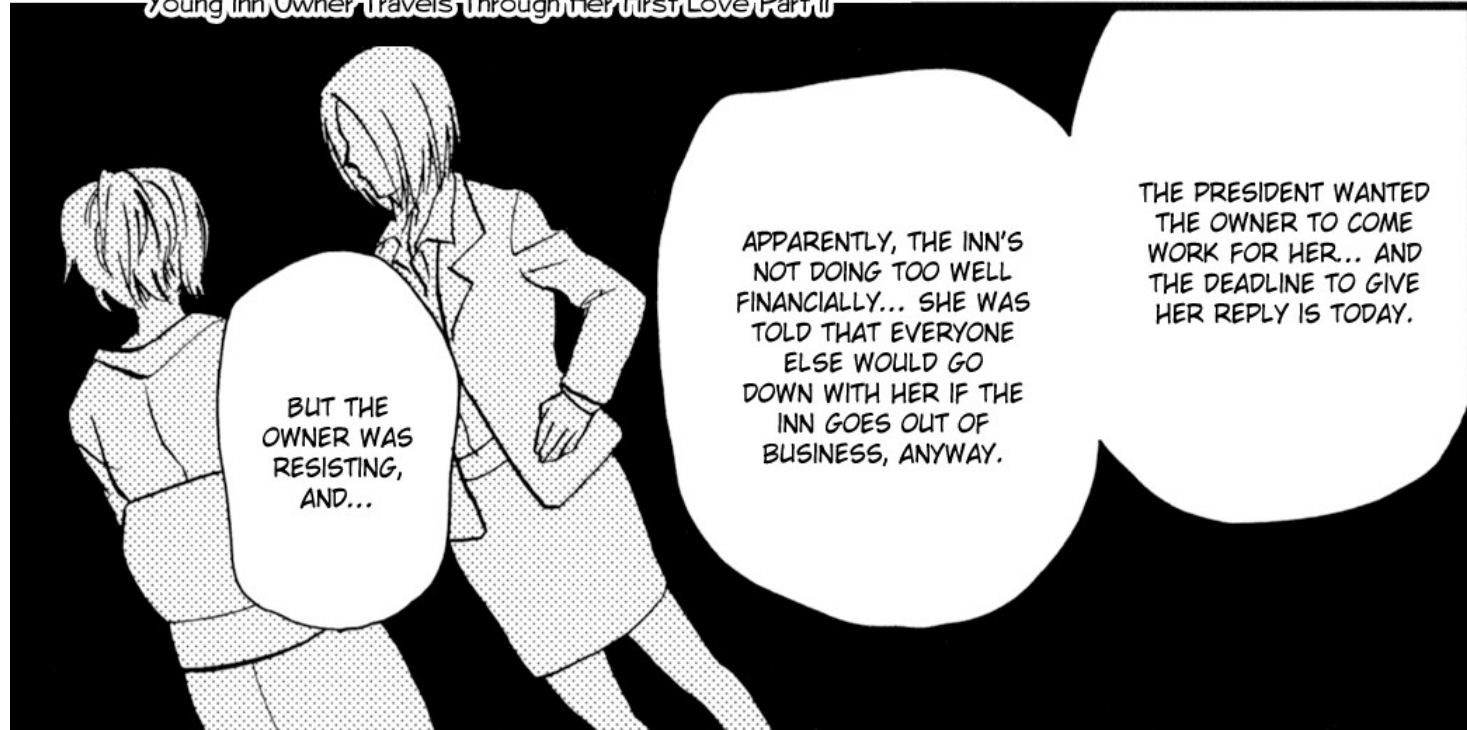



ATTA GIRL,  
ICCHAN!  
WELL SAID!

SO  
TRUE!



THE OWNER  
MUST HAVE  
GONE TO FIGHT  
THE PRESIDENT!

I BELIEVE IN HER!



THE  
CUSTOMERS  
ARE  
ARRIVING.

NOW NOW, WE  
DON'T HAVE TIME  
FOR TALKING.



YEAH...

Even if  
we don't  
get bought  
out...

Chatter

BUT ISN'T  
ONIYURI IN  
TROUBLE?



YEAH!

LET'S DO  
OUR BEST TO  
SHOW OUR  
THANKS TO THE  
HOT SPRING!

WHO CARES IF THIS  
IS THE LAST ONIYURI  
FESTIVAL? WE'VE  
BEEN HAVING FUN  
ALL THESE YEARS!

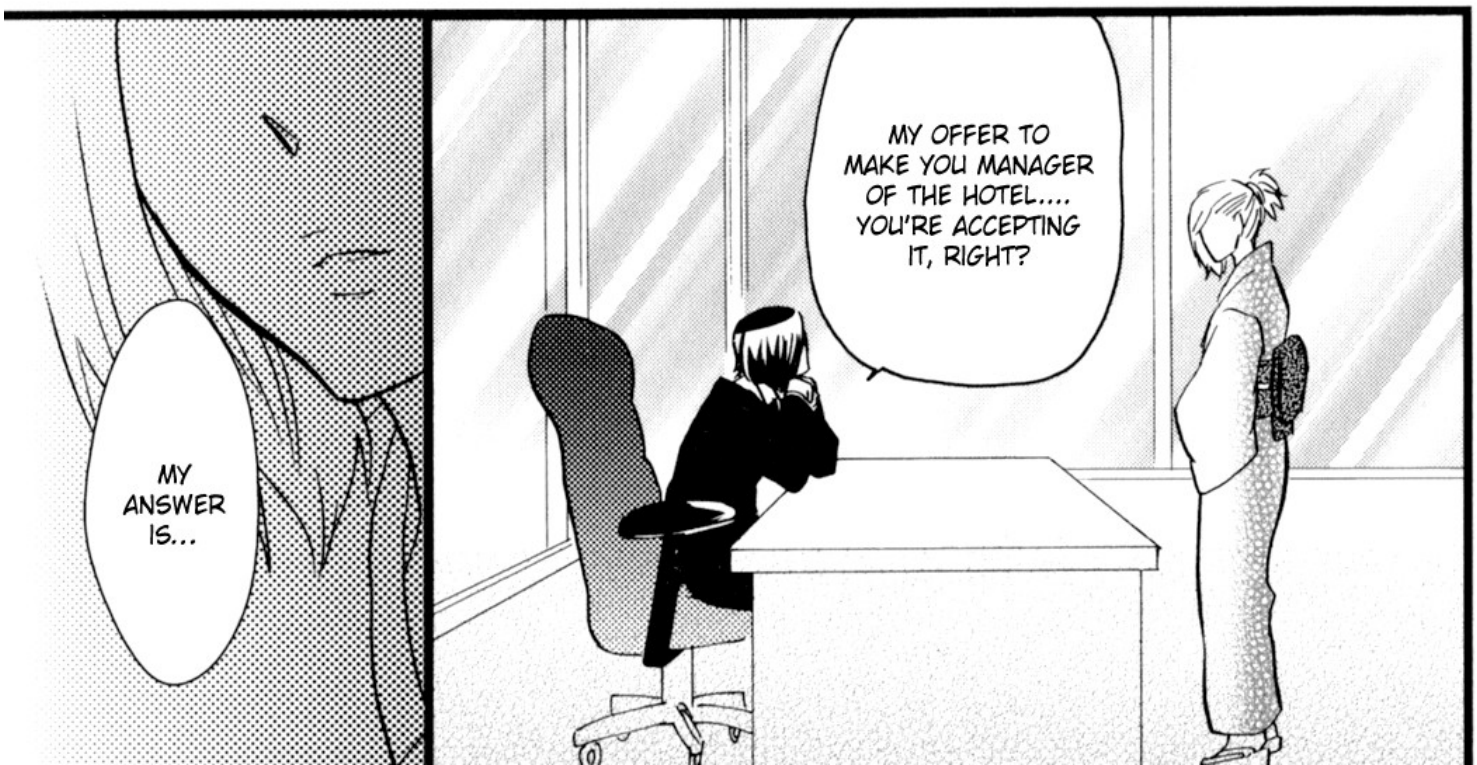
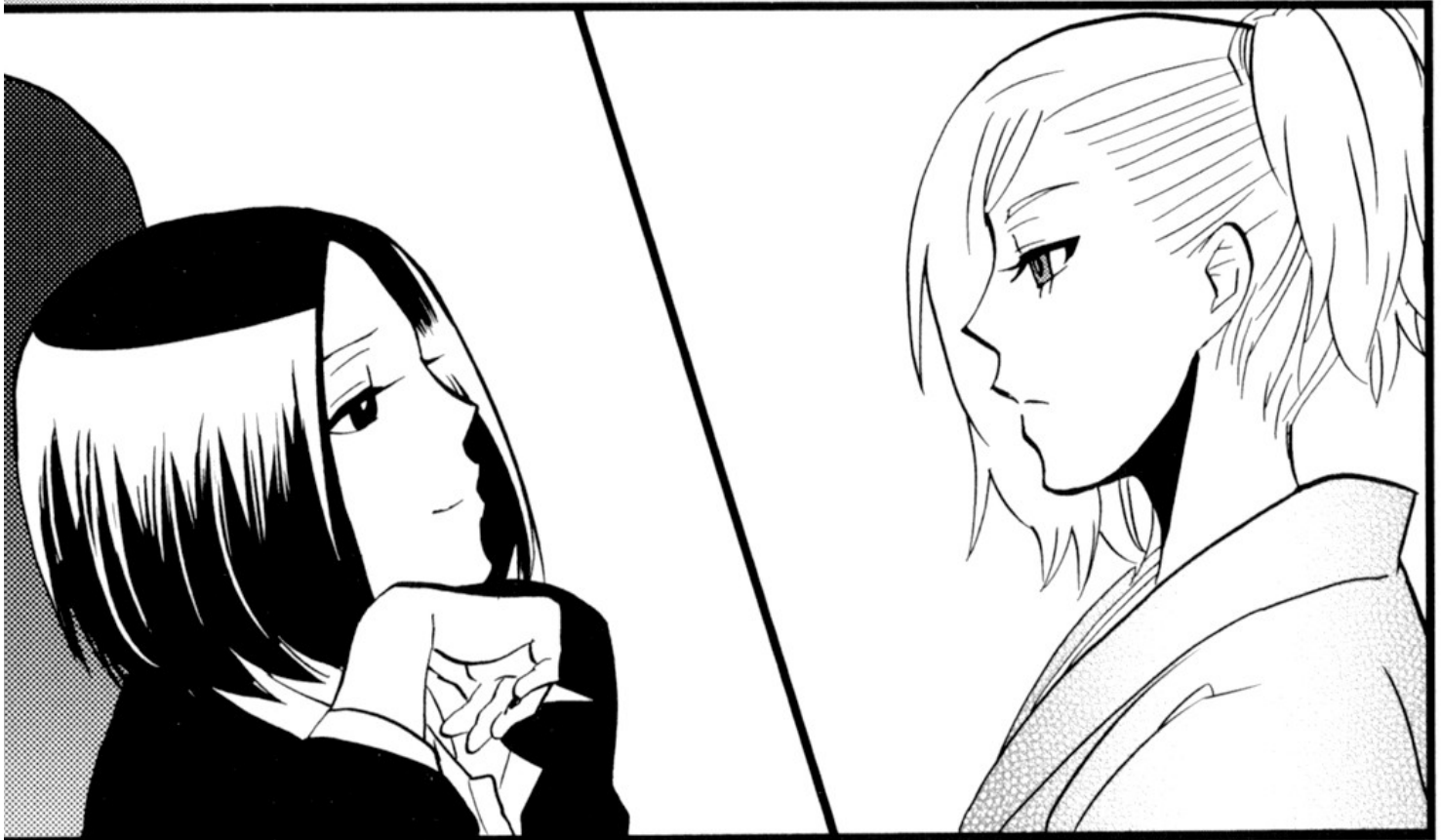
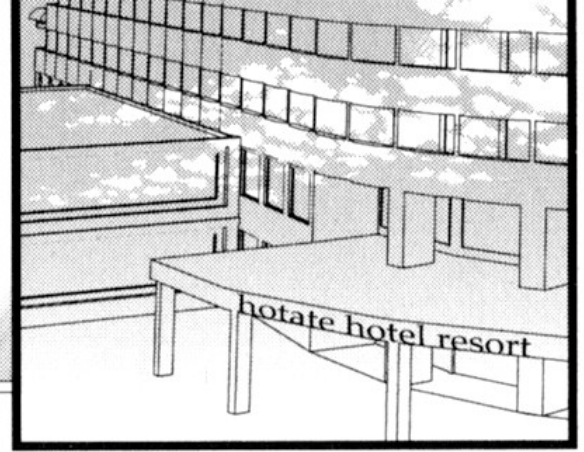



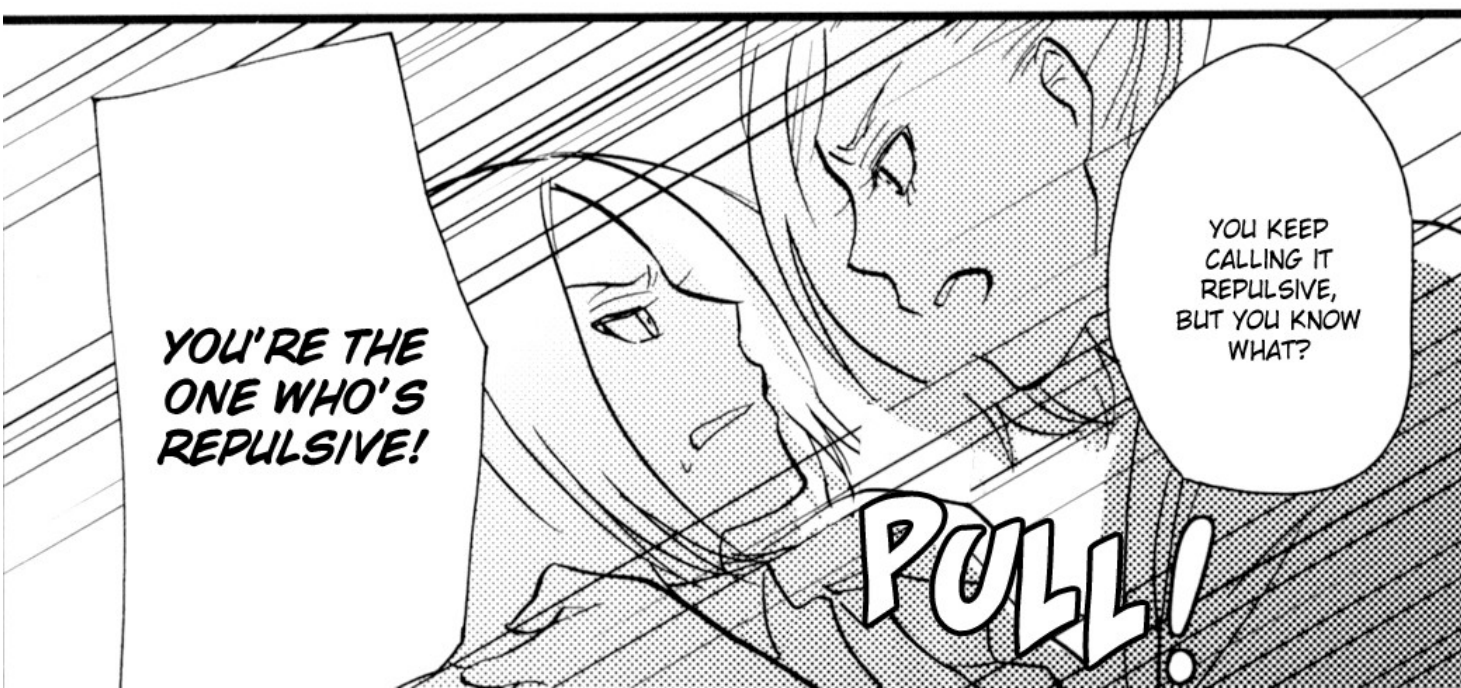
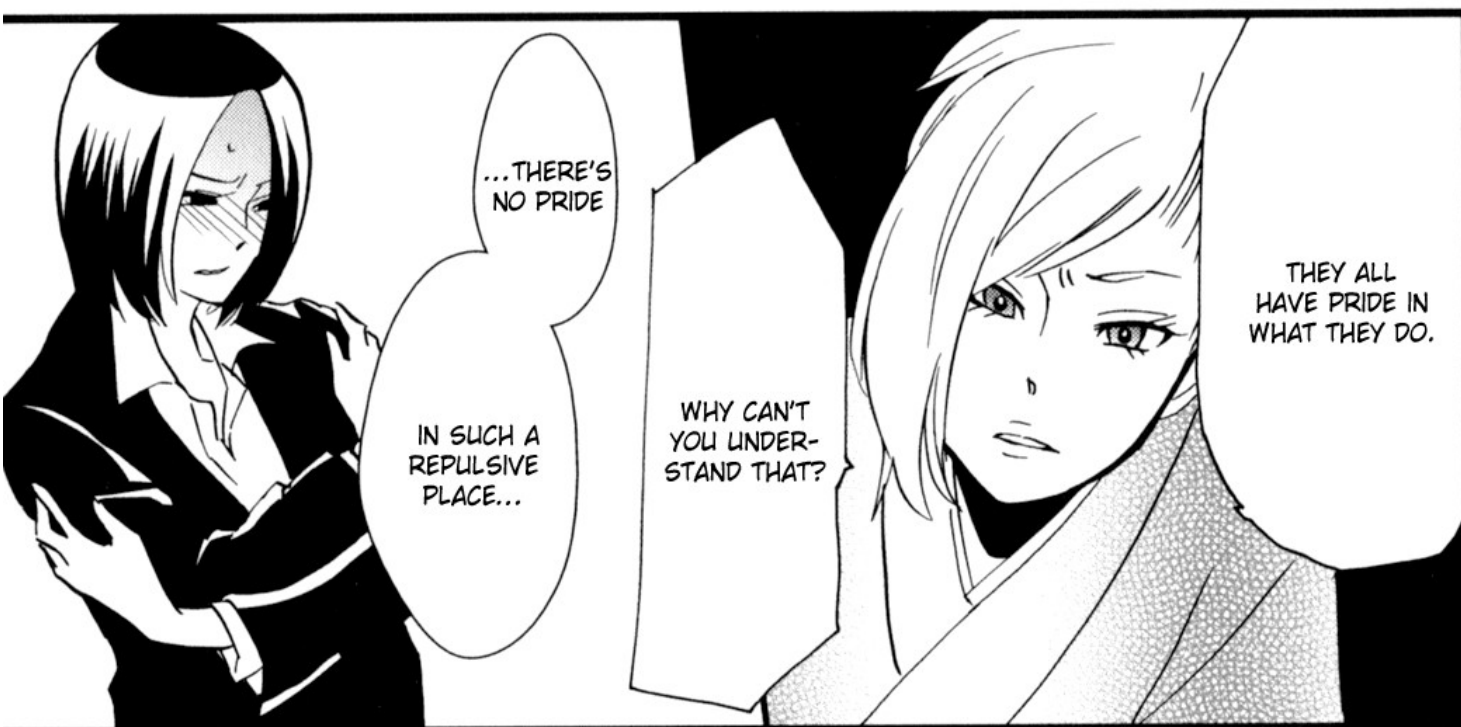

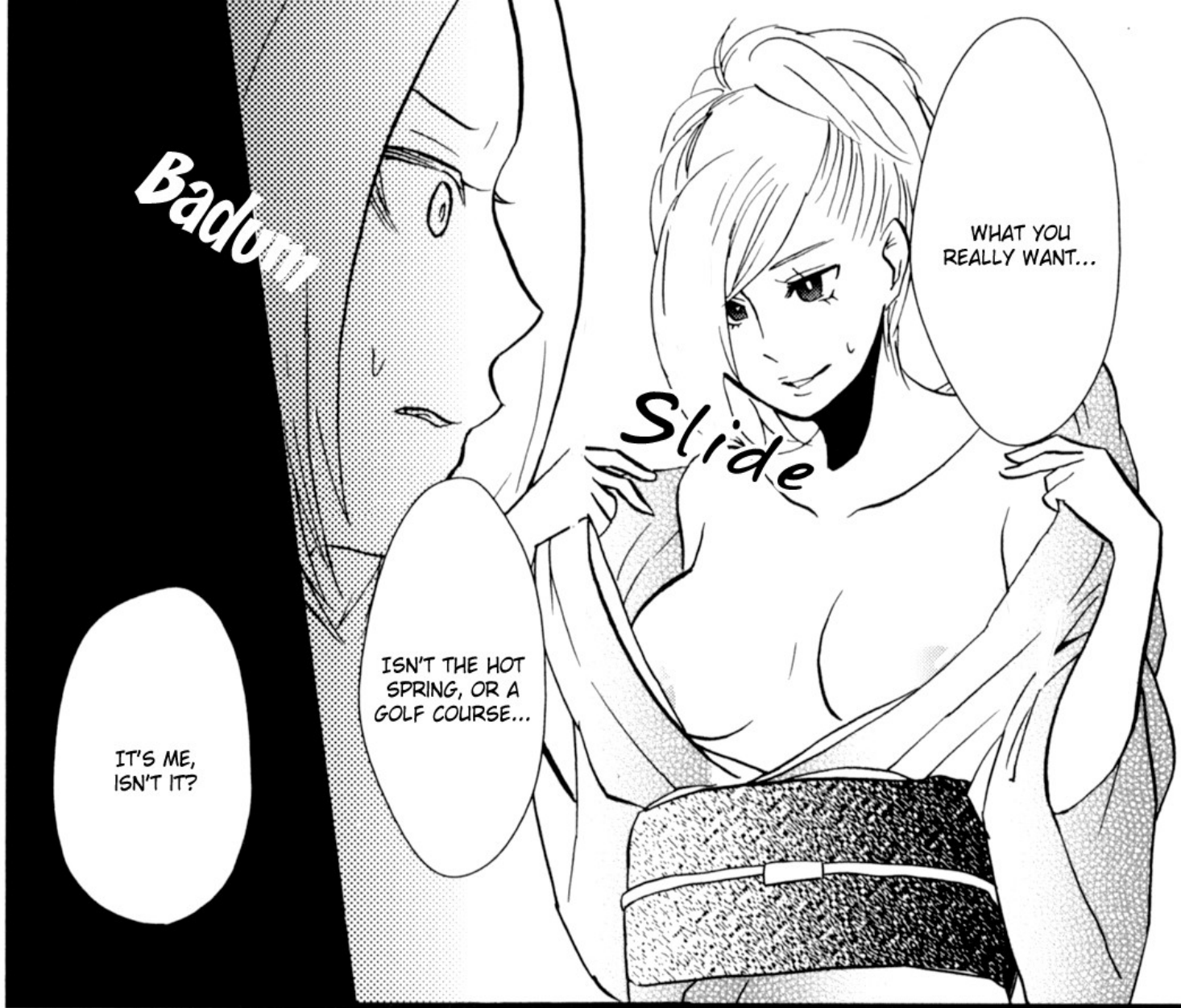

*Badum*

WHAT YOU REALLY WANT...

*Slide*

ISN'T THE HOT SPRING, OR A GOLF COURSE...

IT'S ME, ISN'T IT?

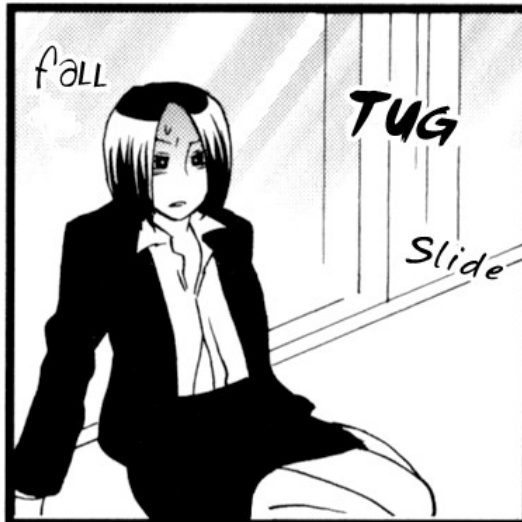

*fall*

*TUG*

*Slide*



**FWOSH**

ARE YOU FUCKING KIDDING ME!?

TRYING TO DEAL WITH IT UNDERHANDEDLY BY USING THE POWER OF YOUR MONEY...



SO WHAT ABOUT IT!?

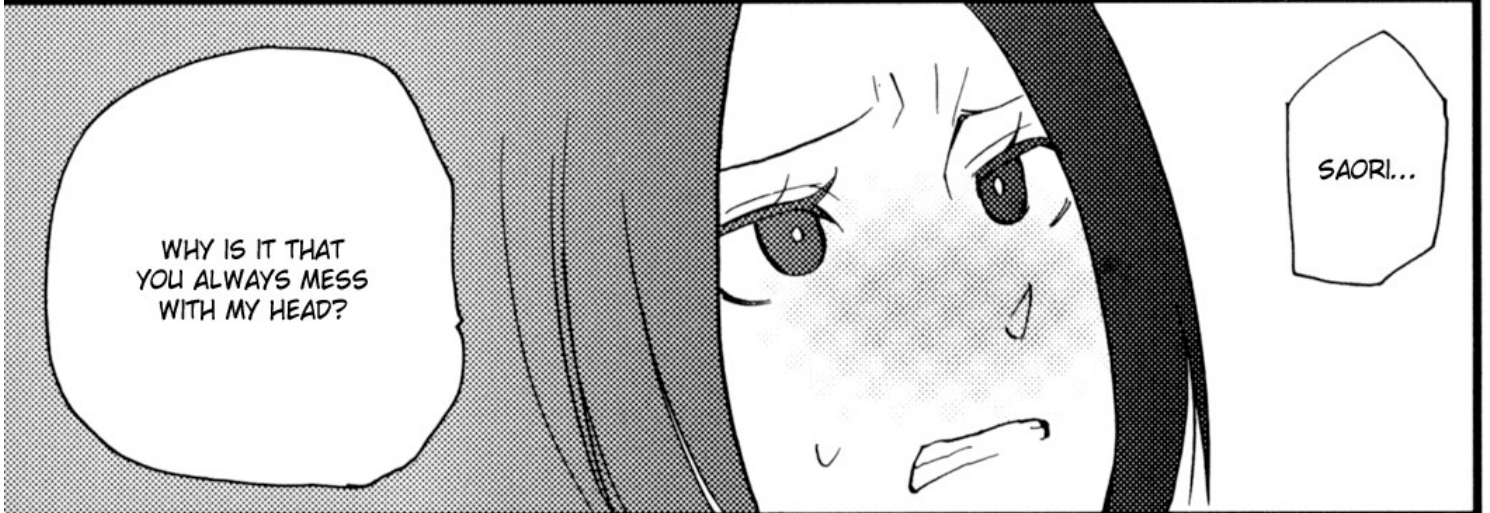

WHY IS IT THAT YOU ALWAYS MESS WITH MY HEAD?

SAORI...

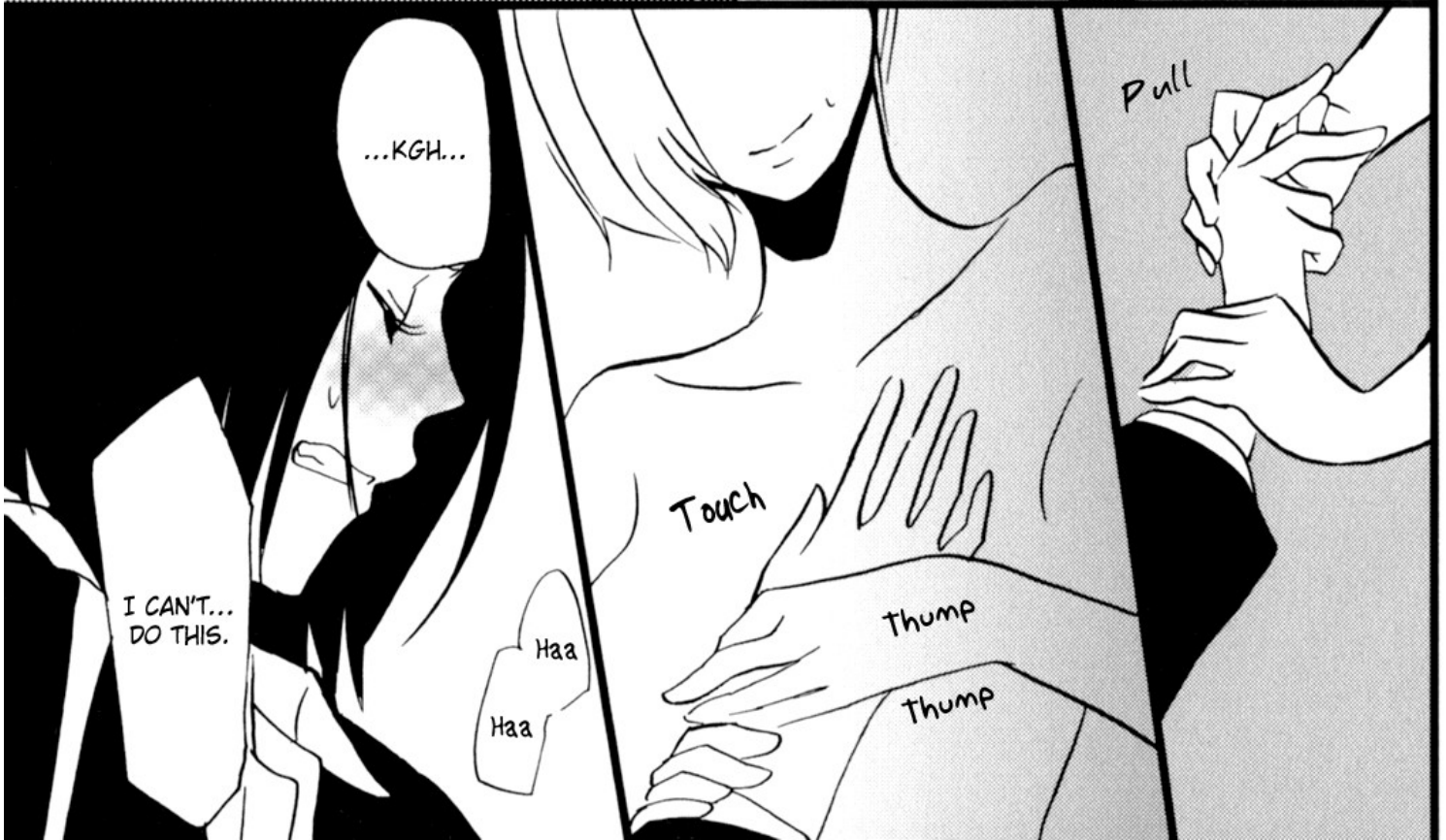

...KGH...

Pull

Touch

Thump

Thump

Haa

Haa

I CAN'T... DO THIS.



WHEN WE'RE  
TOGETHER, I CAN'T  
STOP MYSELF FROM  
LUSTING AFTER YOU.

I WANTED  
TO CHERISH  
YOU, BUT



EVEN NOW...  
AFTER I THOUGHT I WAS  
FINALLY IN CONTROL OF  
MY FEELINGS BY KEEPING  
MY DISTANCE...

I CAN'T FOCUS ON  
ANYTHING ELSE.



THAT'S  
RIGHT...

...YOU LEFT  
ME BECAUSE  
OF THIS?

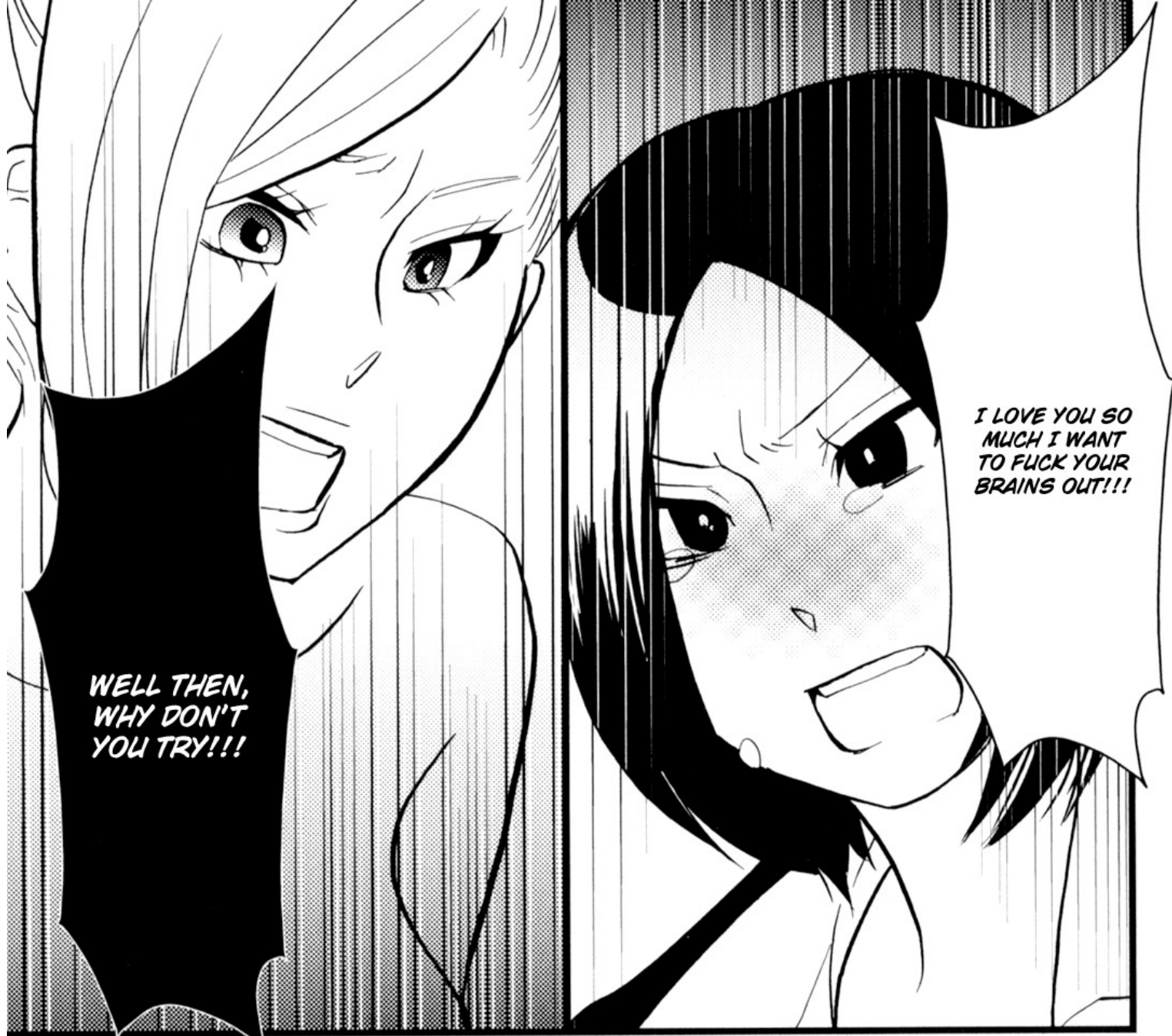

WELL THEN,  
WHY DON'T  
YOU TRY!!!

I LOVE YOU SO  
MUCH I WANT  
TO FUCK YOUR  
BRAINS OUT!!!

I'M NOT SO  
FRAGILE THAT YOU  
HAVE TO WORRY  
ABOUT ME LIKE THIS.

IDIOT...

WHA...

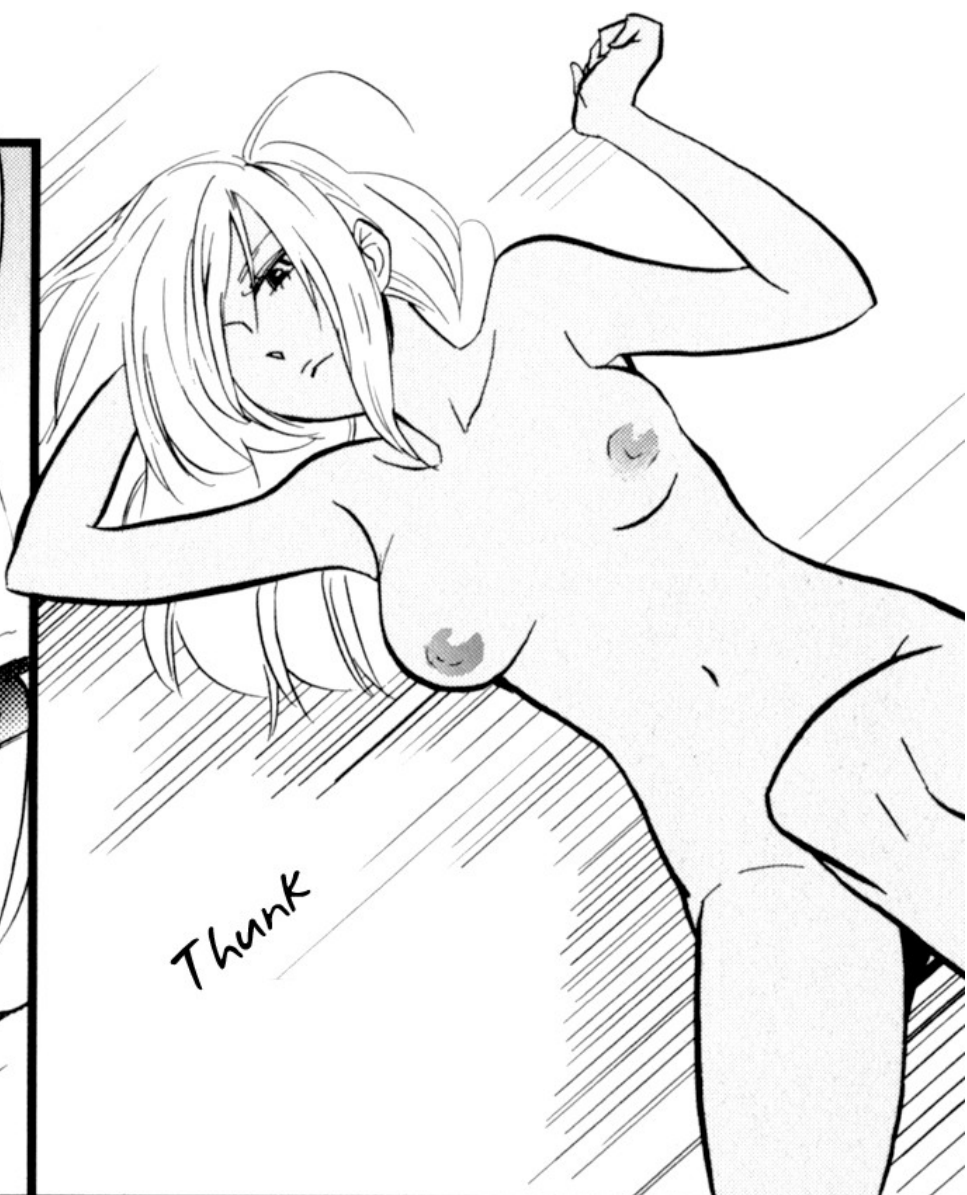

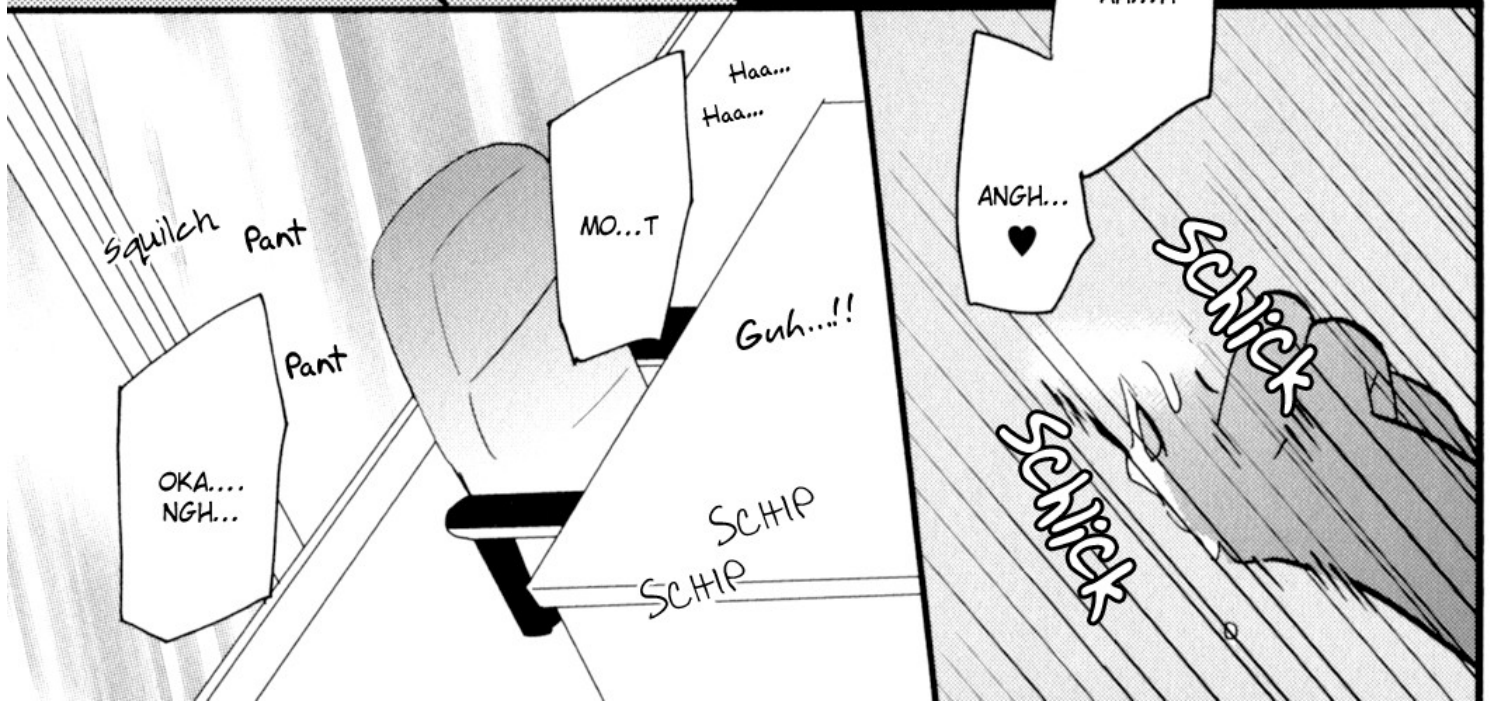
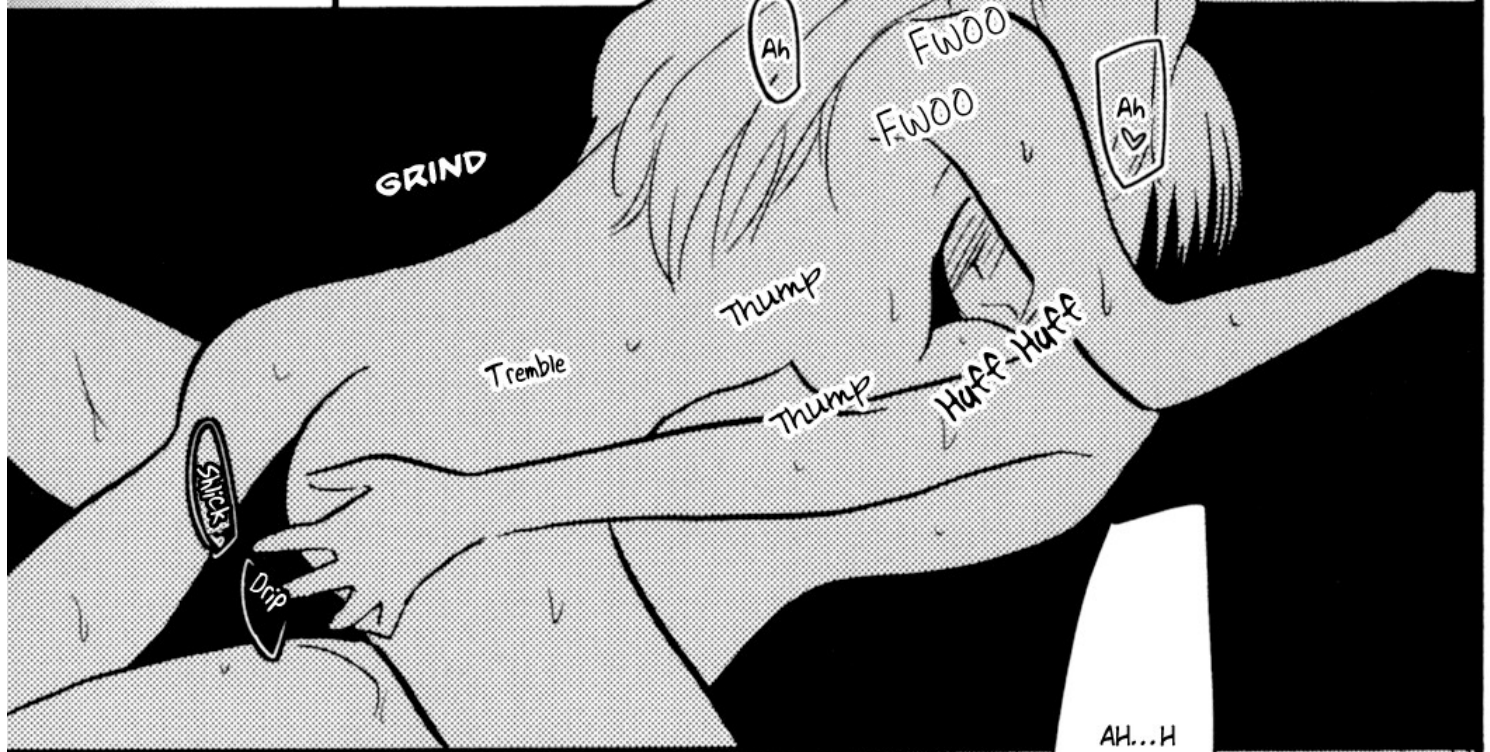
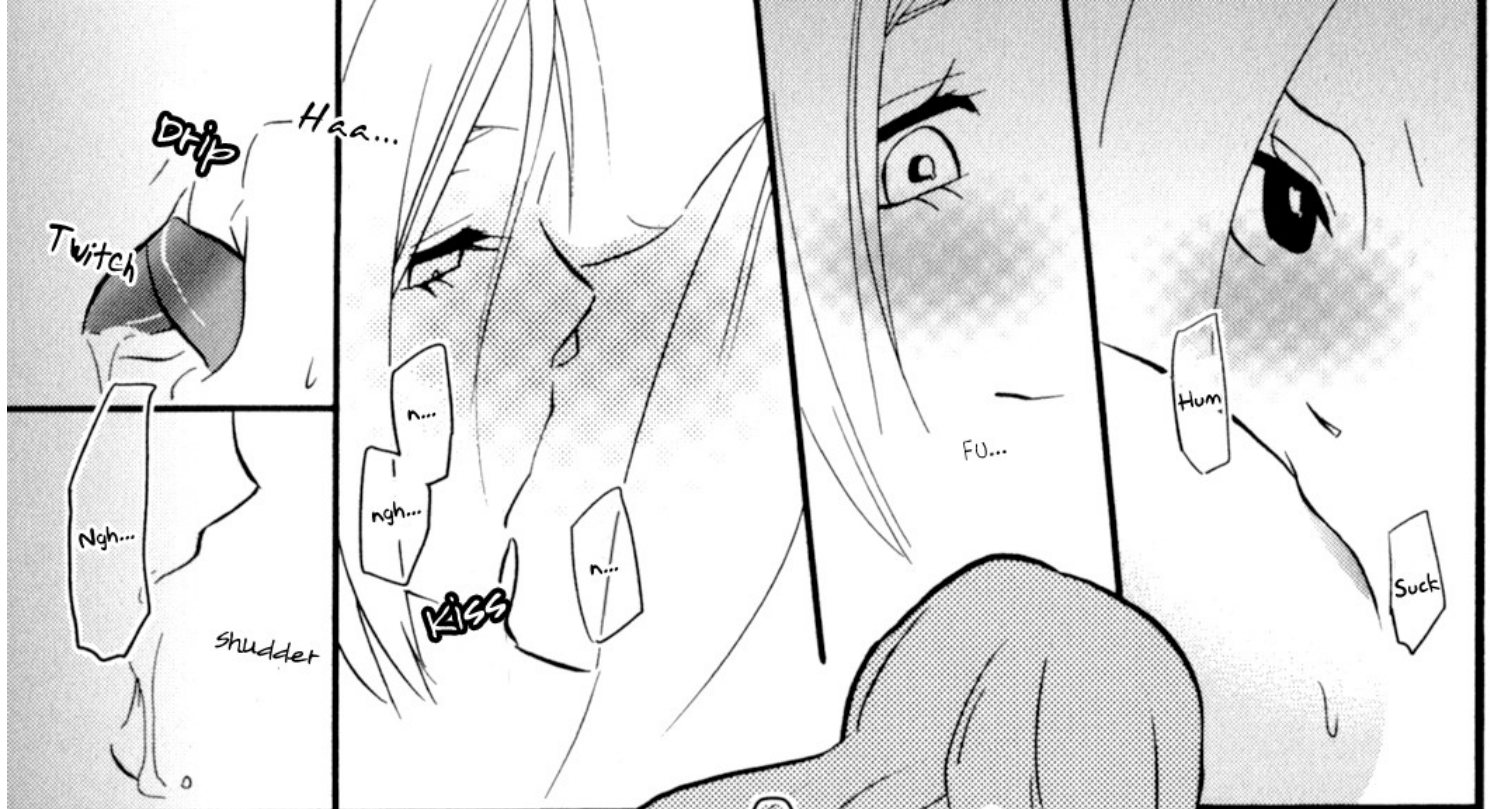

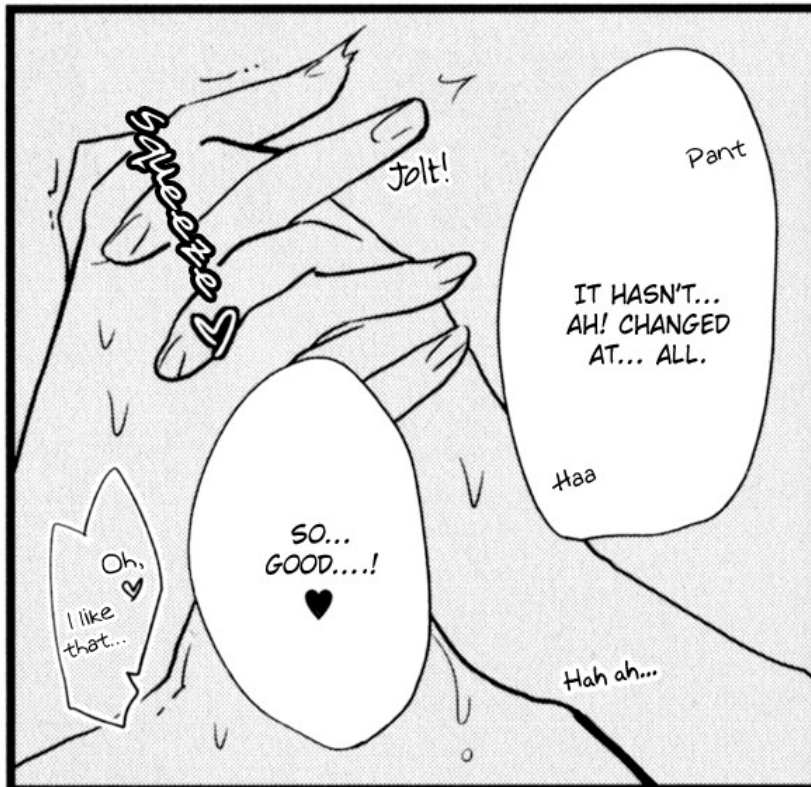
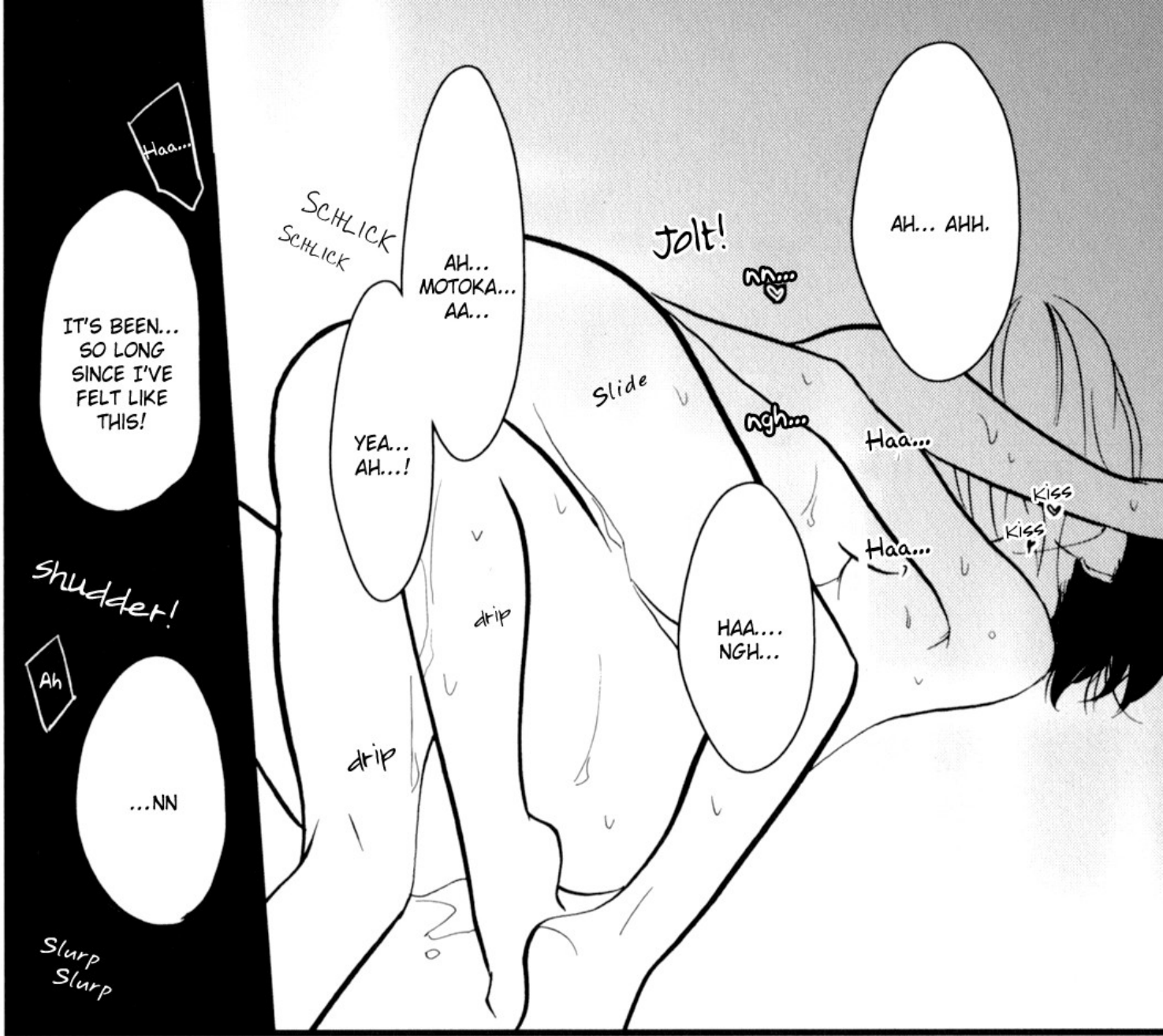

...WE'RE JUST GETTING STARTED...  
♥

WHAT'S THAT, MOTOKA...?



AH... SAORI... IF...Y...SO... TIGHTLY... THEN...  
I... ALREADY... MY HEAD... SO... BLANK...  
Haa... Haa...



AAHH...

...FWAH...

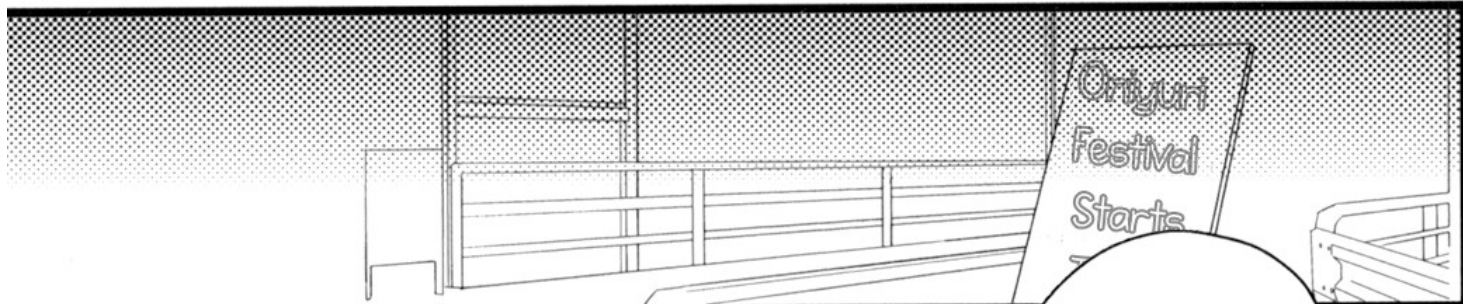

The sun's setting already

AARRGHH! WHAT IS THE OWNER DOING?!

Obvious parody of Yuri Hime

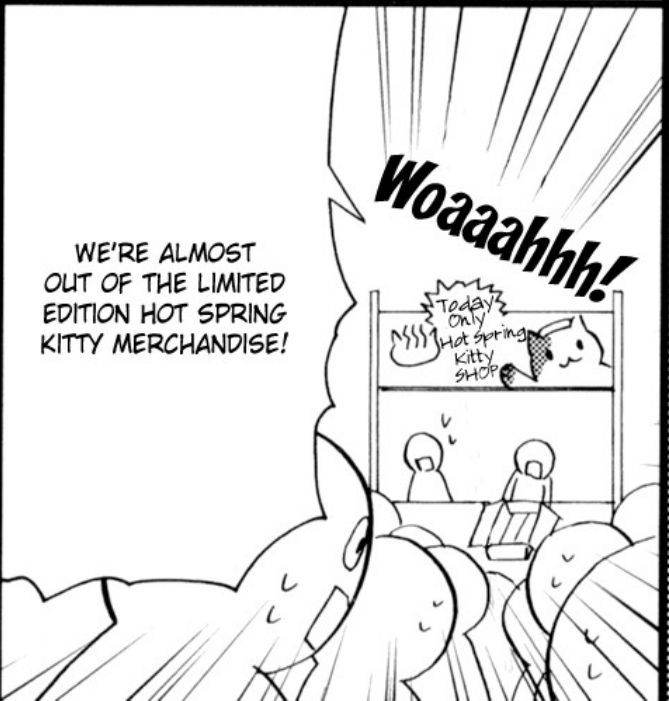
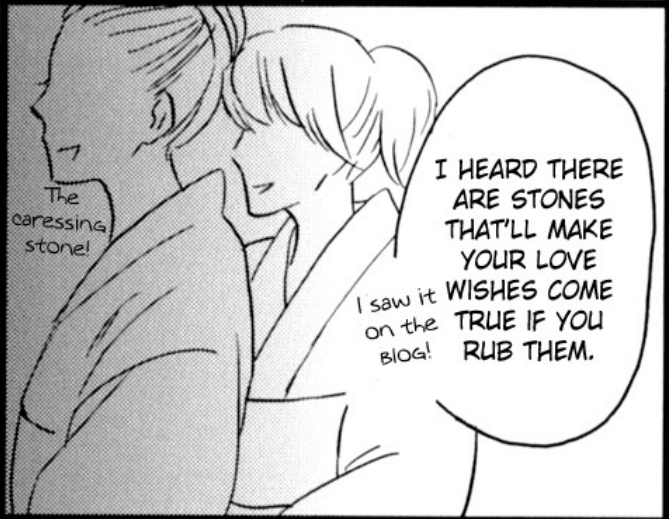
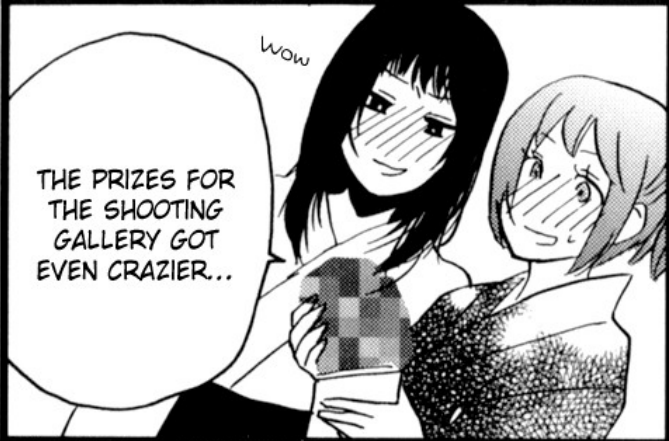

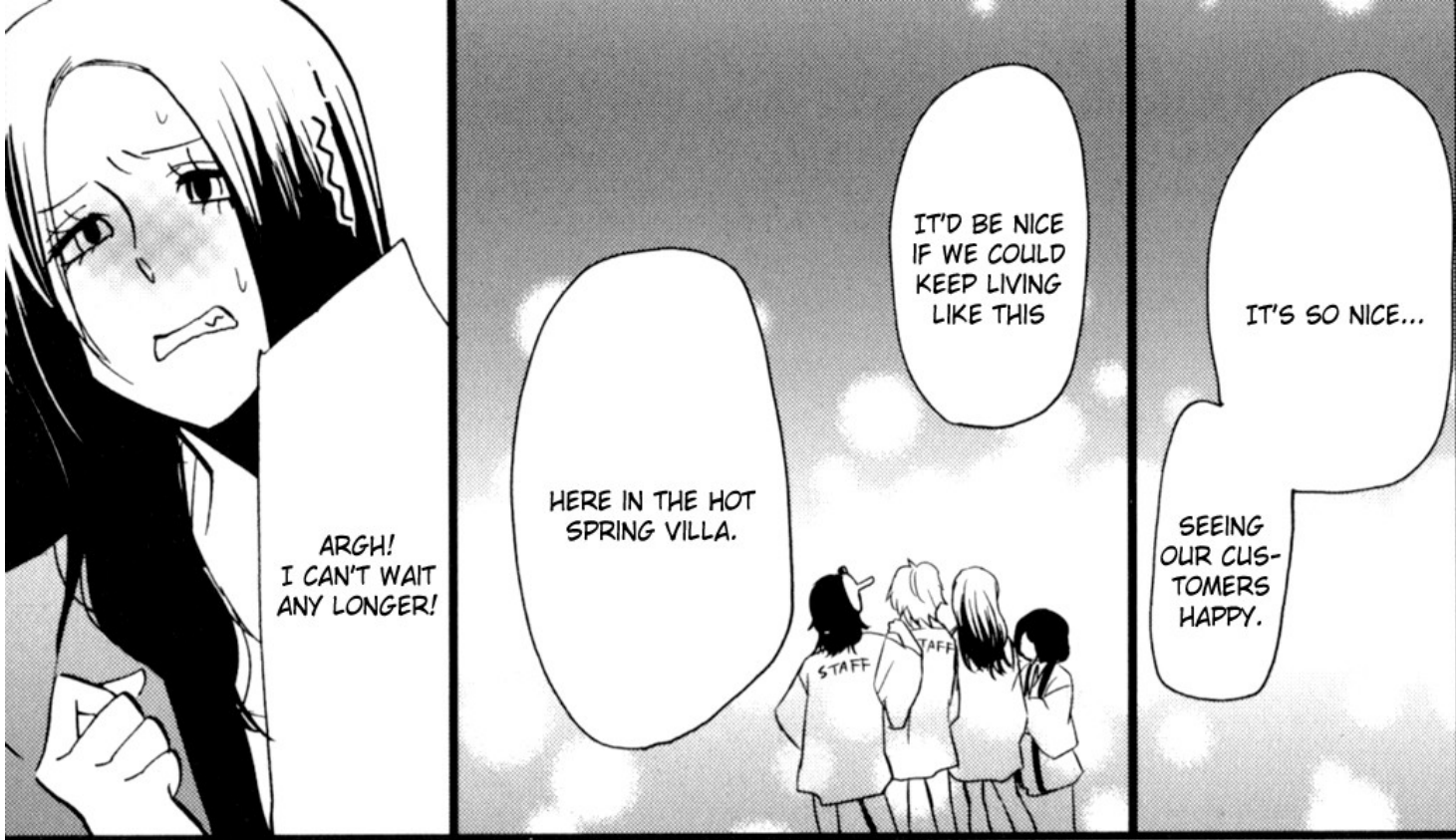

ARGH!  
I CAN'T WAIT  
ANY LONGER!

HERE IN THE HOT  
SPRING VILLA.

IT'D BE NICE  
IF WE COULD  
KEEP LIVING  
LIKE THIS

IT'S SO NICE...

SEEING  
OUR CUS-  
TOMERS  
HAPPY.

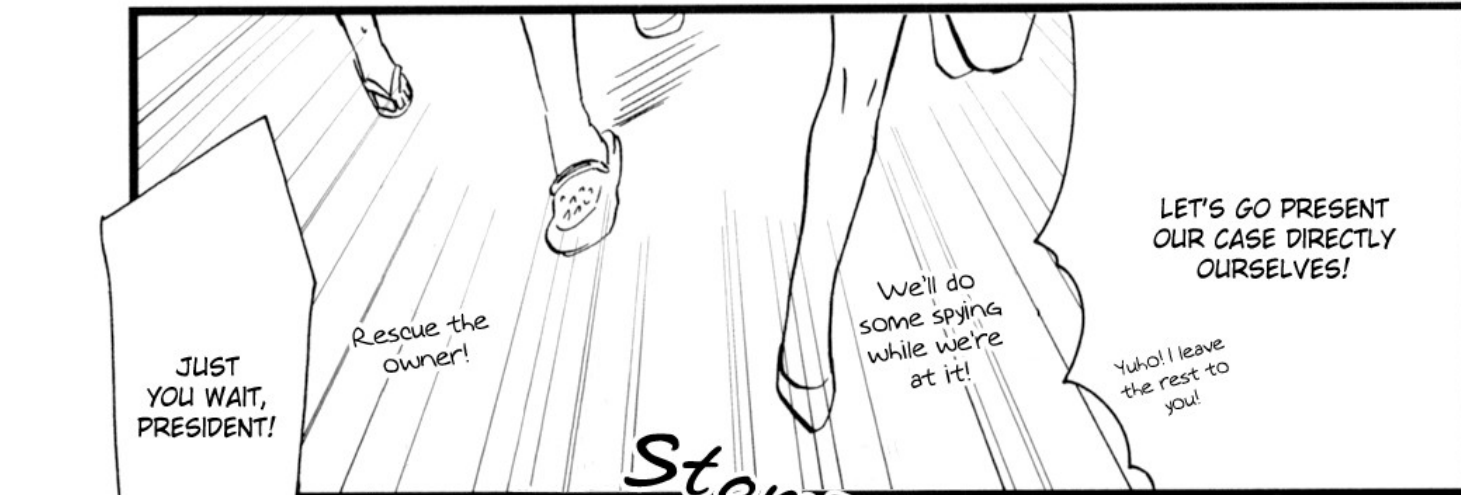

JUST  
YOU WAIT,  
PRESIDENT!

Rescue the  
owner!

We'll do  
some spying  
while we're  
at it!

Yuhoh! I leave  
the rest to  
you!

LET'S GO PRESENT  
OUR CASE DIRECTLY  
OURSELVES!

Stomp

Stomp



AH!

Impossible

We should  
make a  
resort  
Bath too.

NOW...  
WHERE DID  
THEY GET  
TO?

Resort  
Outdoor Bath

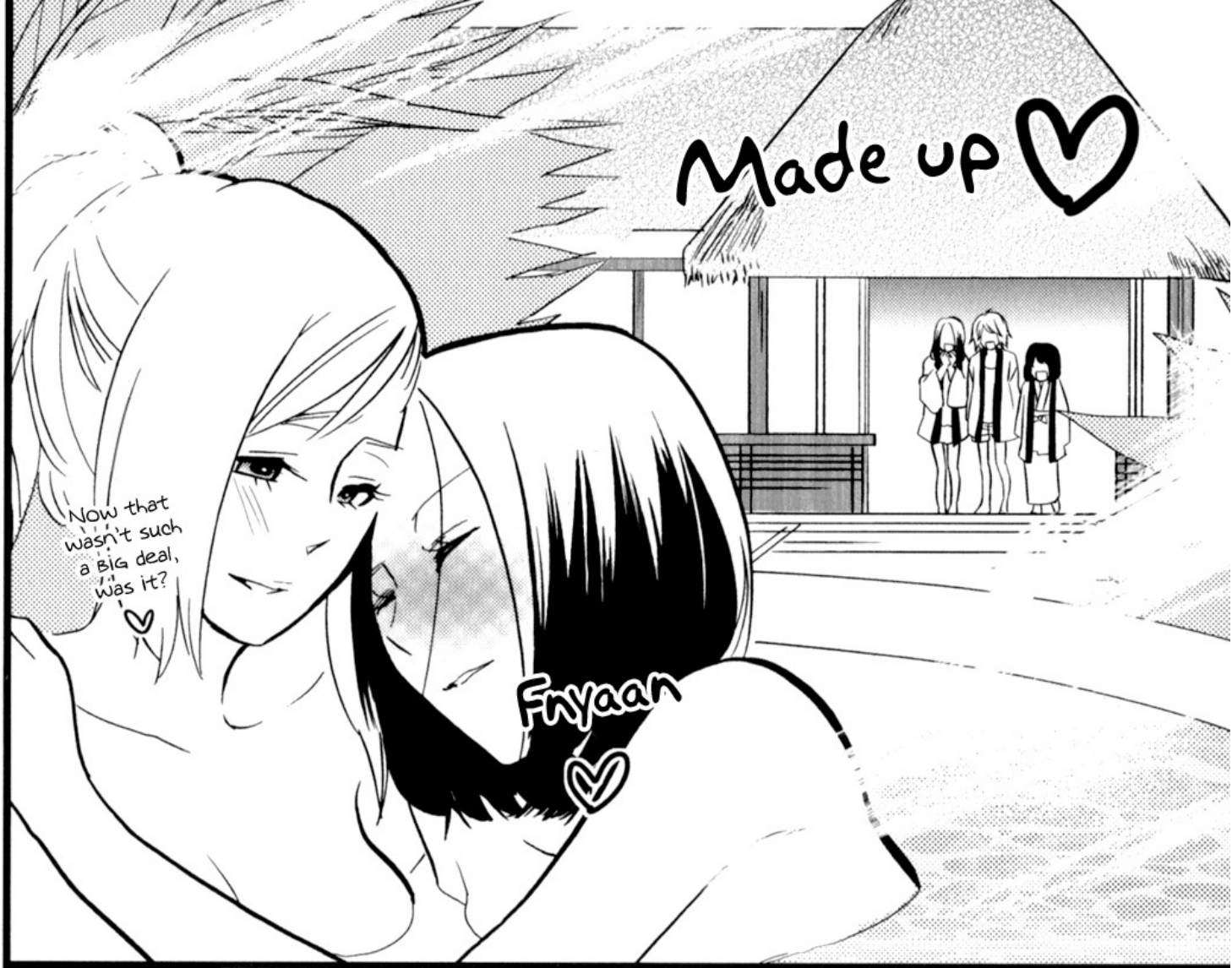

Made up ♡

Now that wasn't such a BIG deal, was it? ♡

Fryaan ♡



Huh?

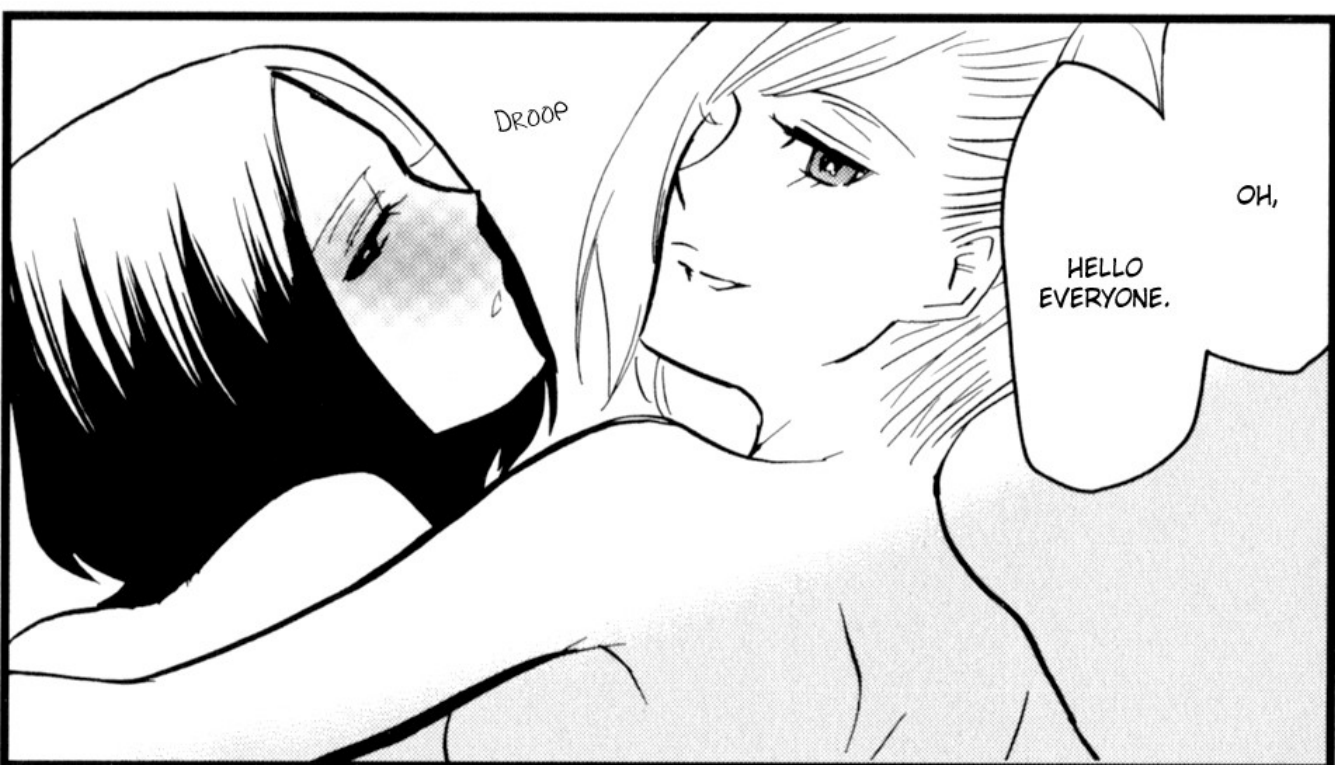

DROOP

OH,  
HELLO EVERYONE.

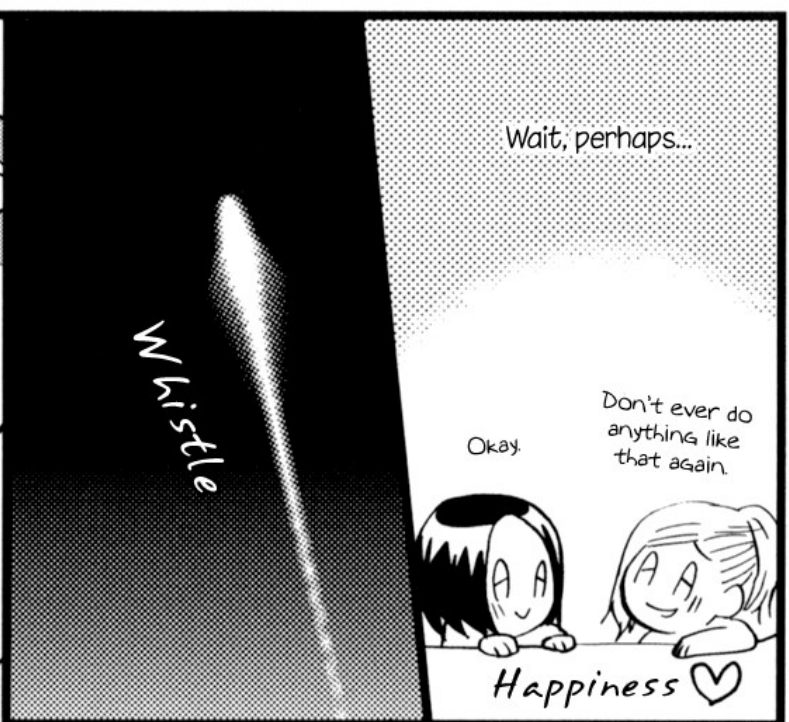
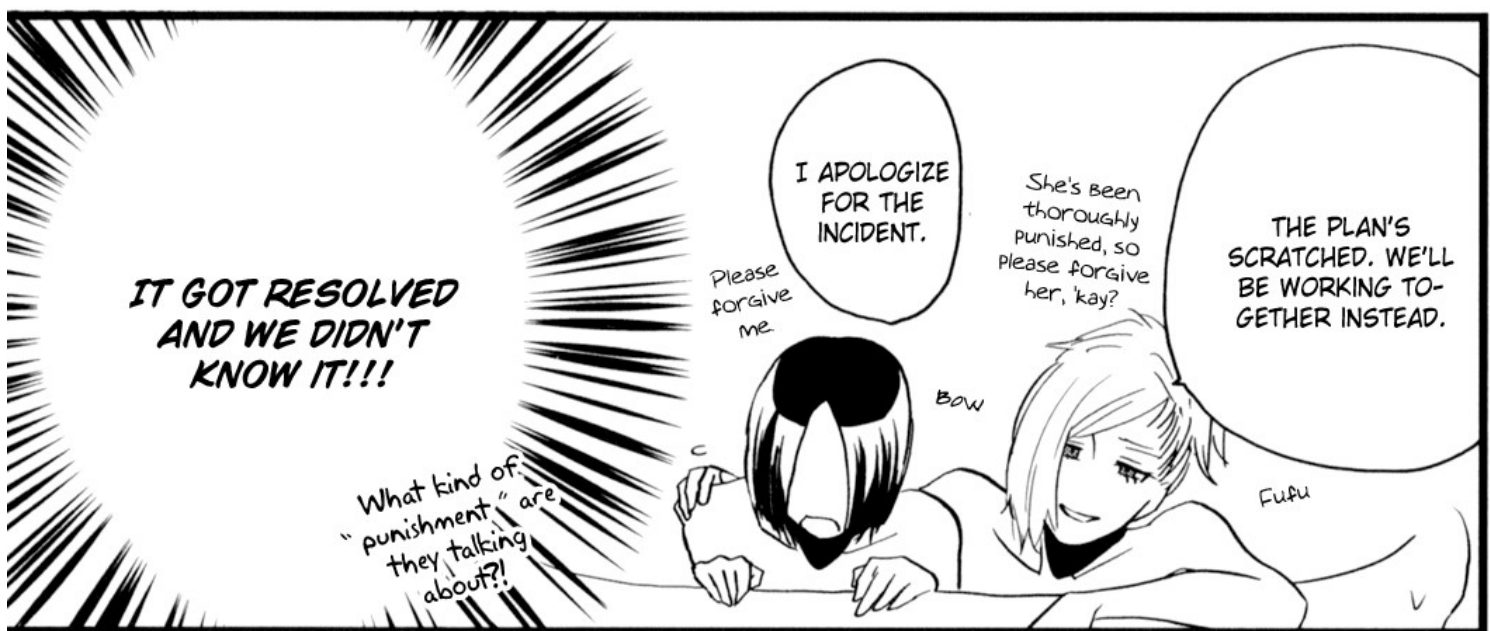
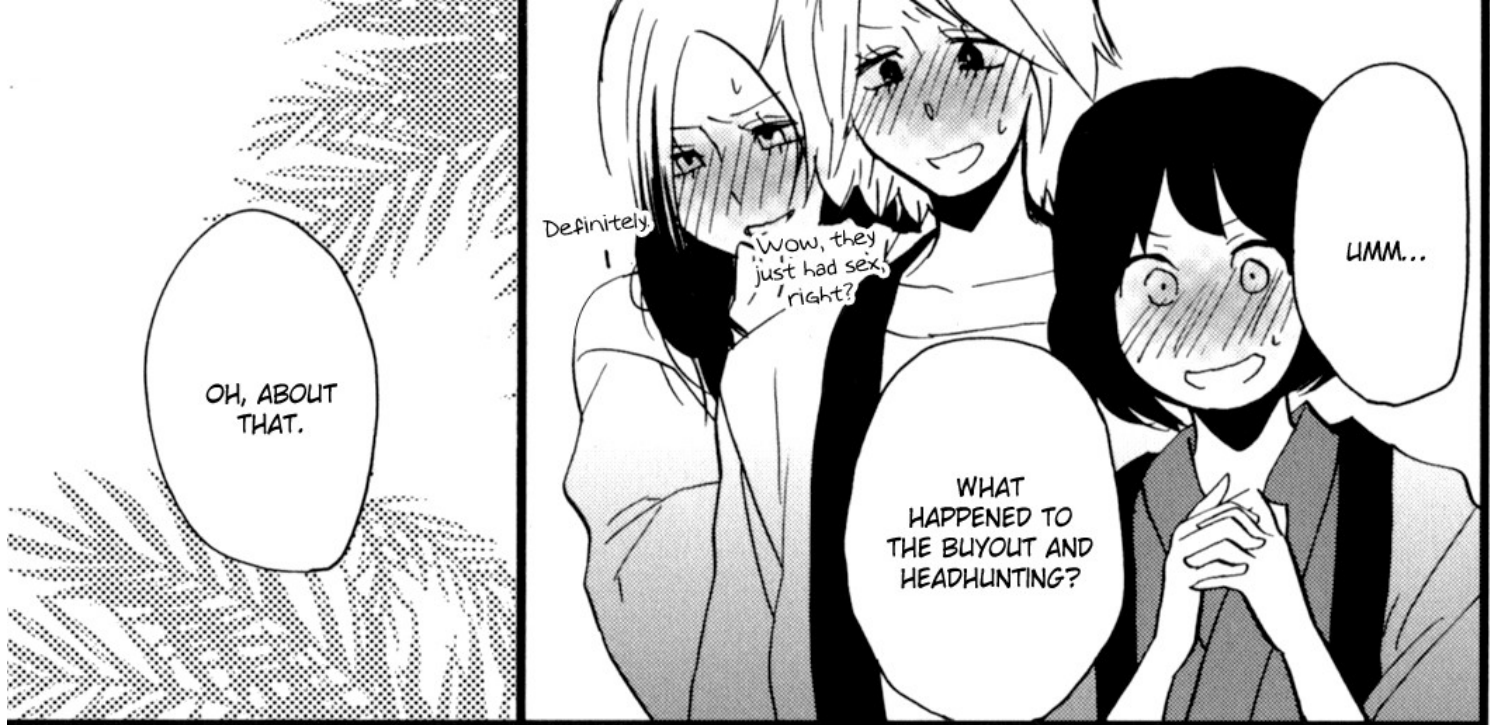



ended up being a huge hit.

The Oniyuri Festival



and the Hot Springs was once again filled with commotion and vitality.

The unprecedented degree of success brought tons of repeat customers

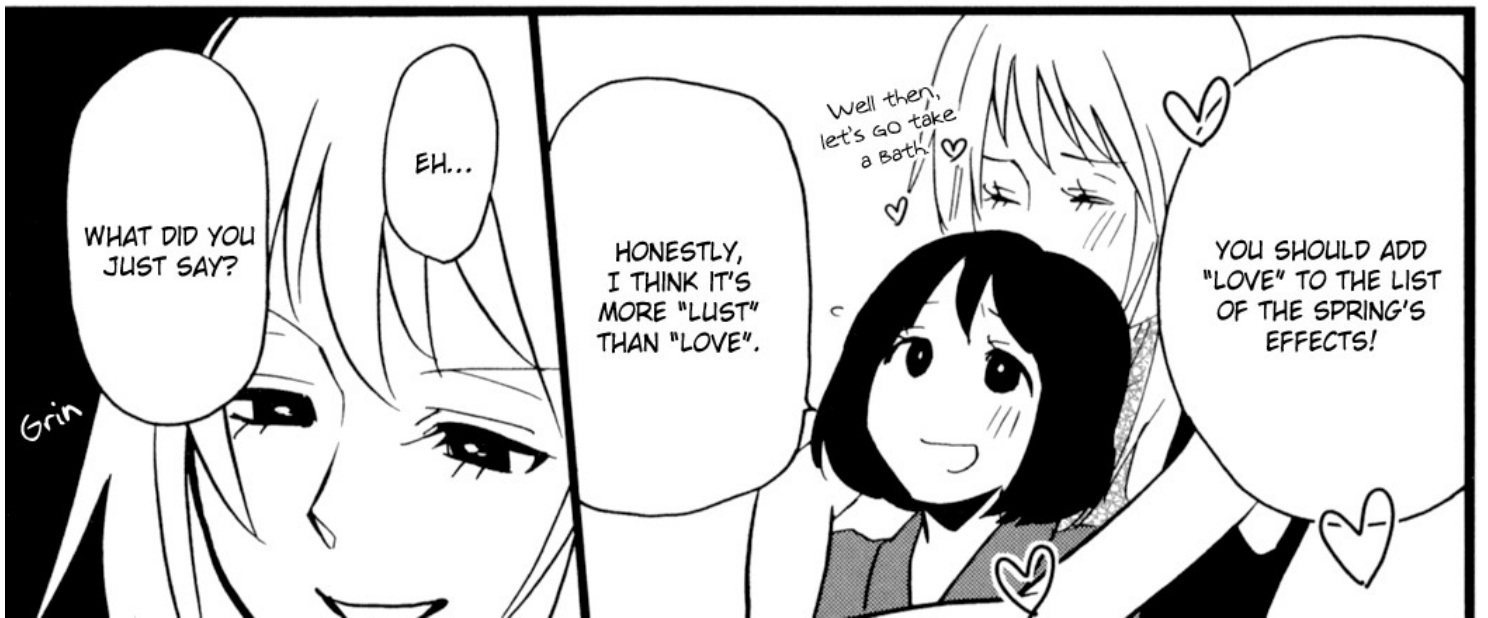
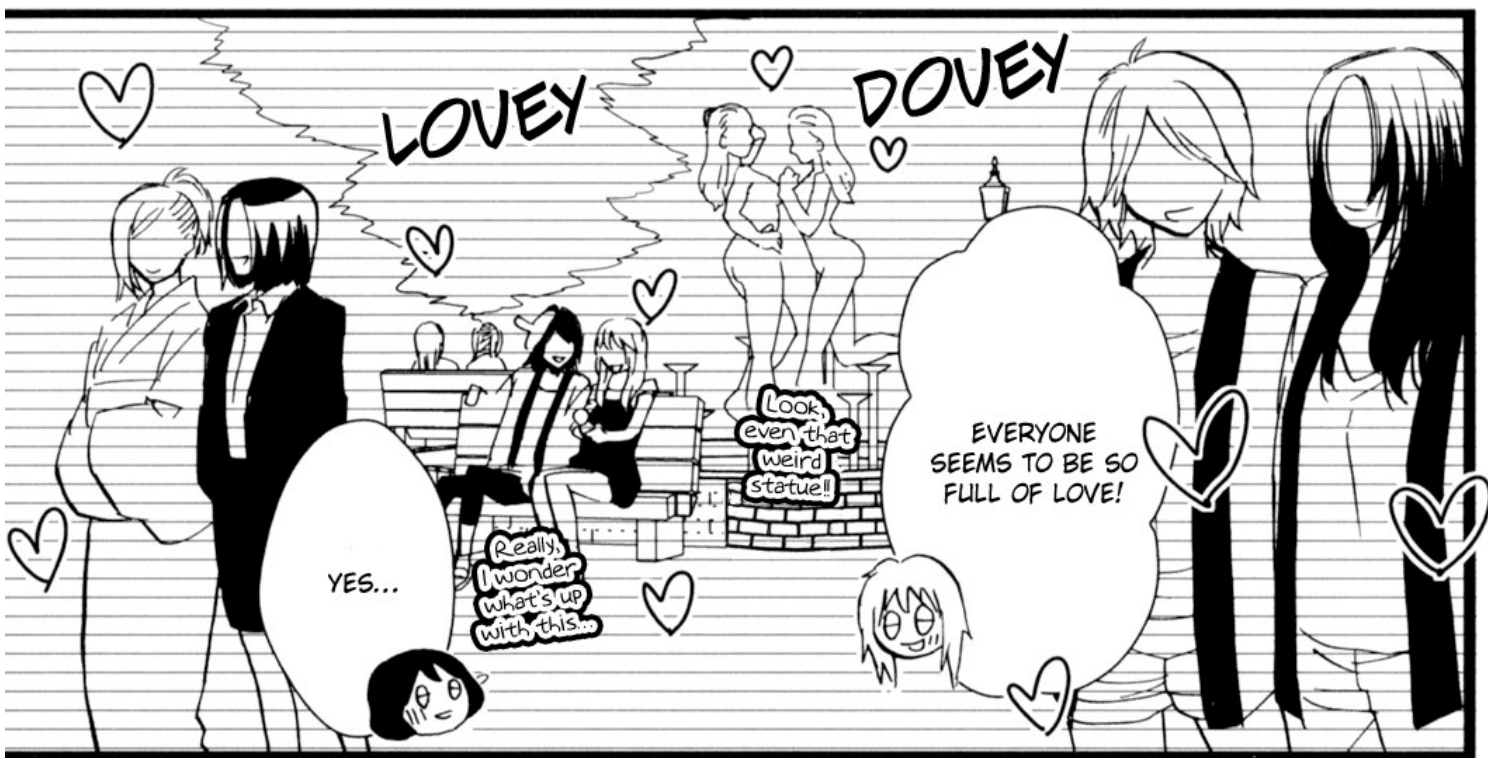
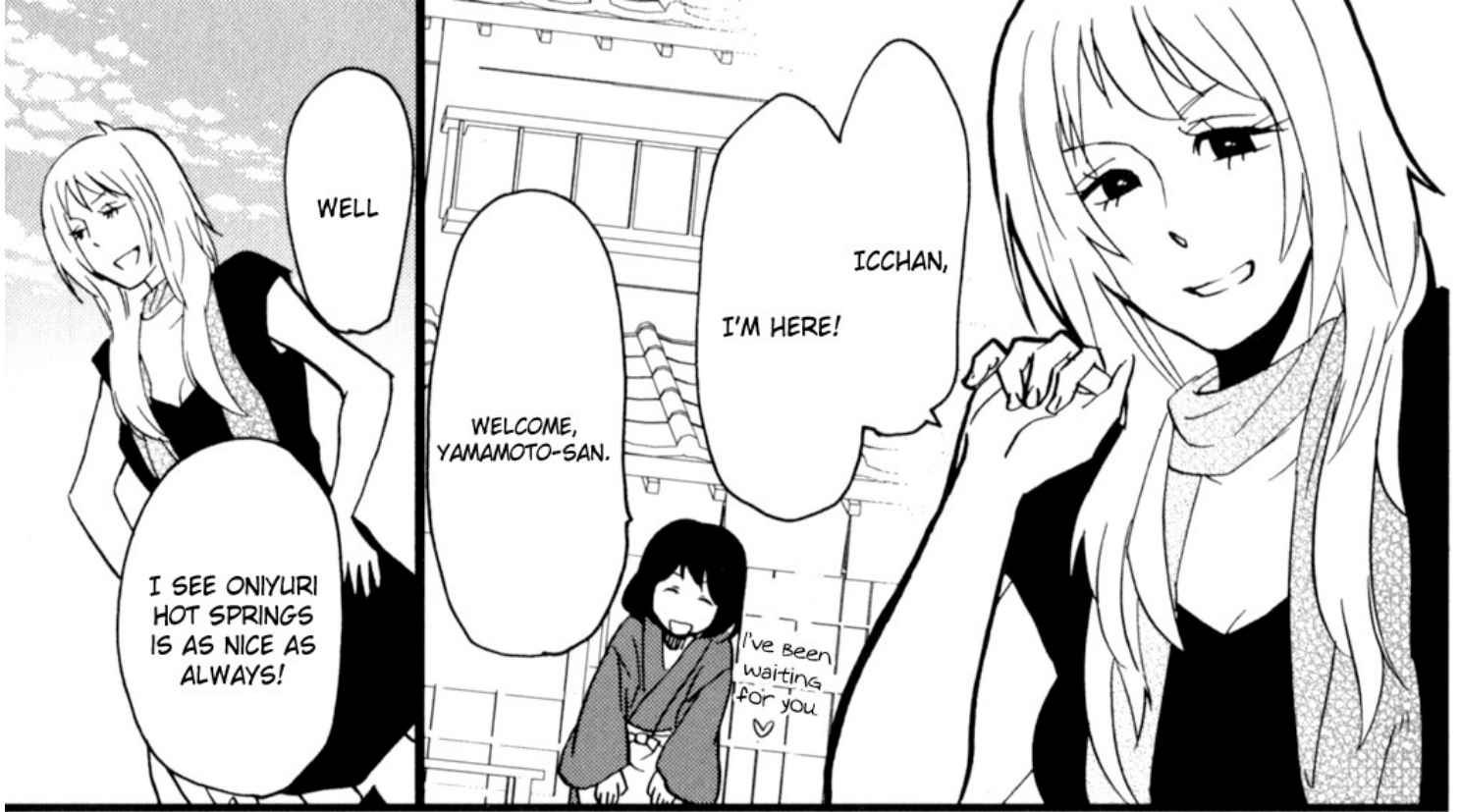



TN: First yokuşou means "Bath" while the second means "lust" They sound the same but use different kanjis.

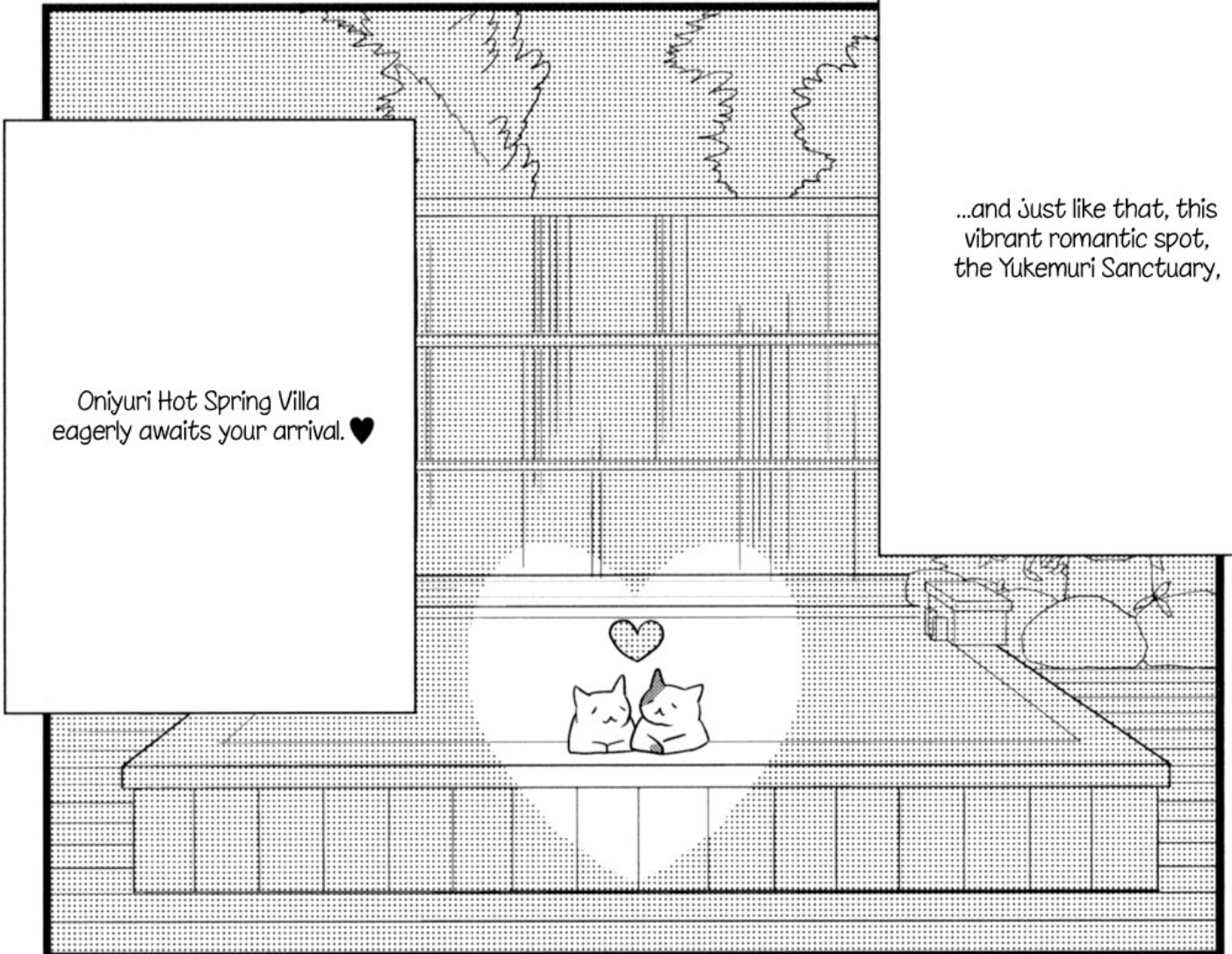

Oniyuri Hot Spring Villa  
eagerly awaits your arrival. ♡

...and just like that, this  
vibrant romantic spot,  
the Yukemuri Sanctuary,

YUKEMURI SANCTUARY END

# Afterword

It's full  
of boobs!!

I'm Amano  
Shuninta!!

It's not  
Shunin-tan

From my very  
first book

I LOVE  
YOU!!!

The person who is  
holding this book right  
now!! Thank you so much!  
Nice to meet you!!



Cough

WELL  
THEN,

ERM.

Oh, and here's a  
little trivia. The  
characters' last names  
are derived from  
names of shellfishes,  
because it's erotic.  
Shijimi (basket dams),  
Hotate (Scallop),  
Satou-gai (Scapharca  
satowi), Tamaki-gai  
(Aroida)

Representing  
the cast, we would  
like a word from  
Ms. Saori, the Inn  
Owner.

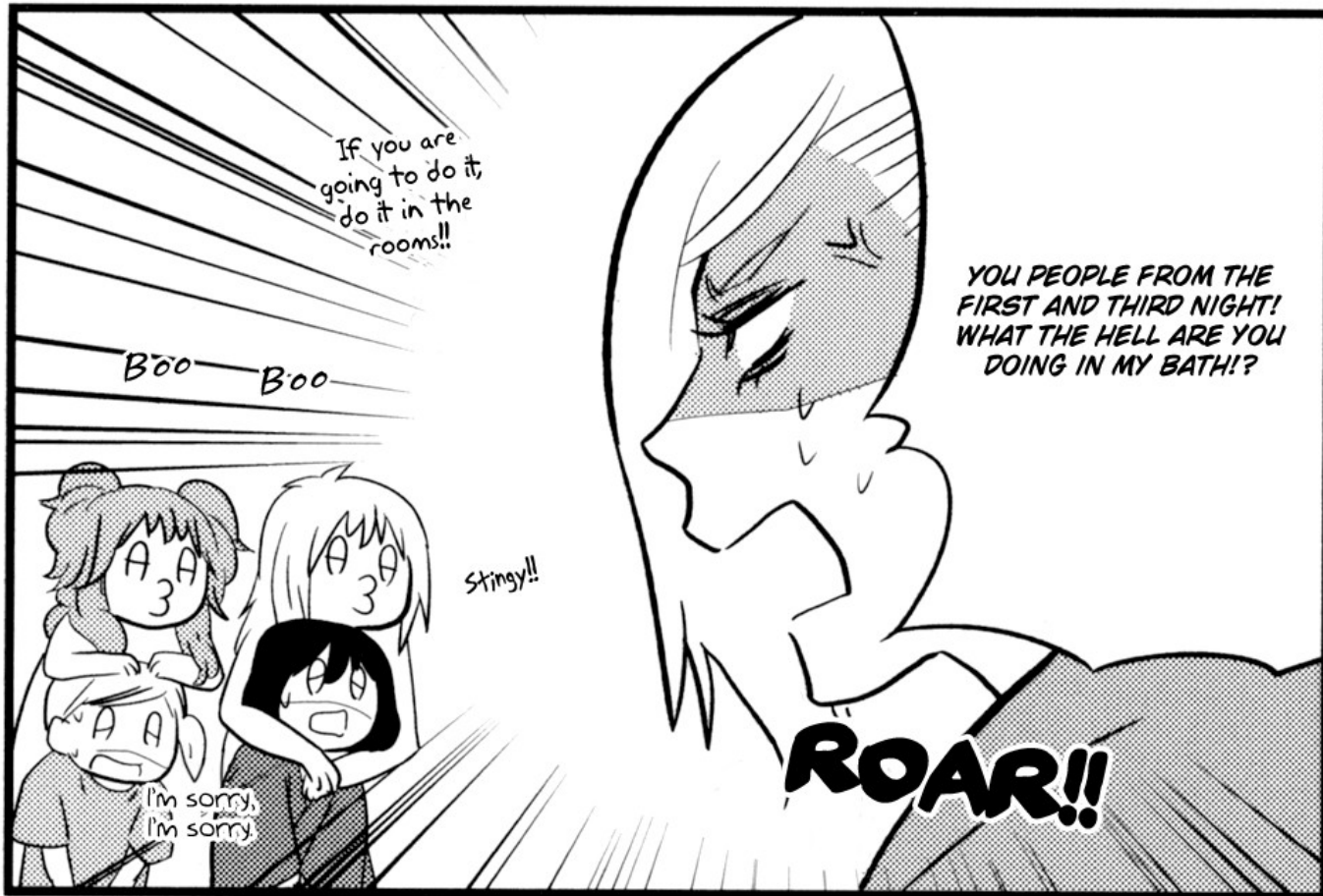

If you are going to do it, do it in the rooms!!

Boo Boo

Stinky!!

I'm sorry, I'm sorry.

YOU PEOPLE FROM THE FIRST AND THIRD NIGHT! WHAT THE HELL ARE YOU DOING IN MY BATH!?

ROAR!!



Ahaan  
It's a promise!

Everyone, please refrain from such activities in public baths. ♡

From here, it's the story of Shuninta.



While being trained by Richy-san, I was submitting my works to their Newcomers Award Contest.

Then one day, I got a mail from my friend!

Story  
Art  
Pen handling

I wanted to get on Yuri Hime, so I was bringing in my works there.

TREMBLE

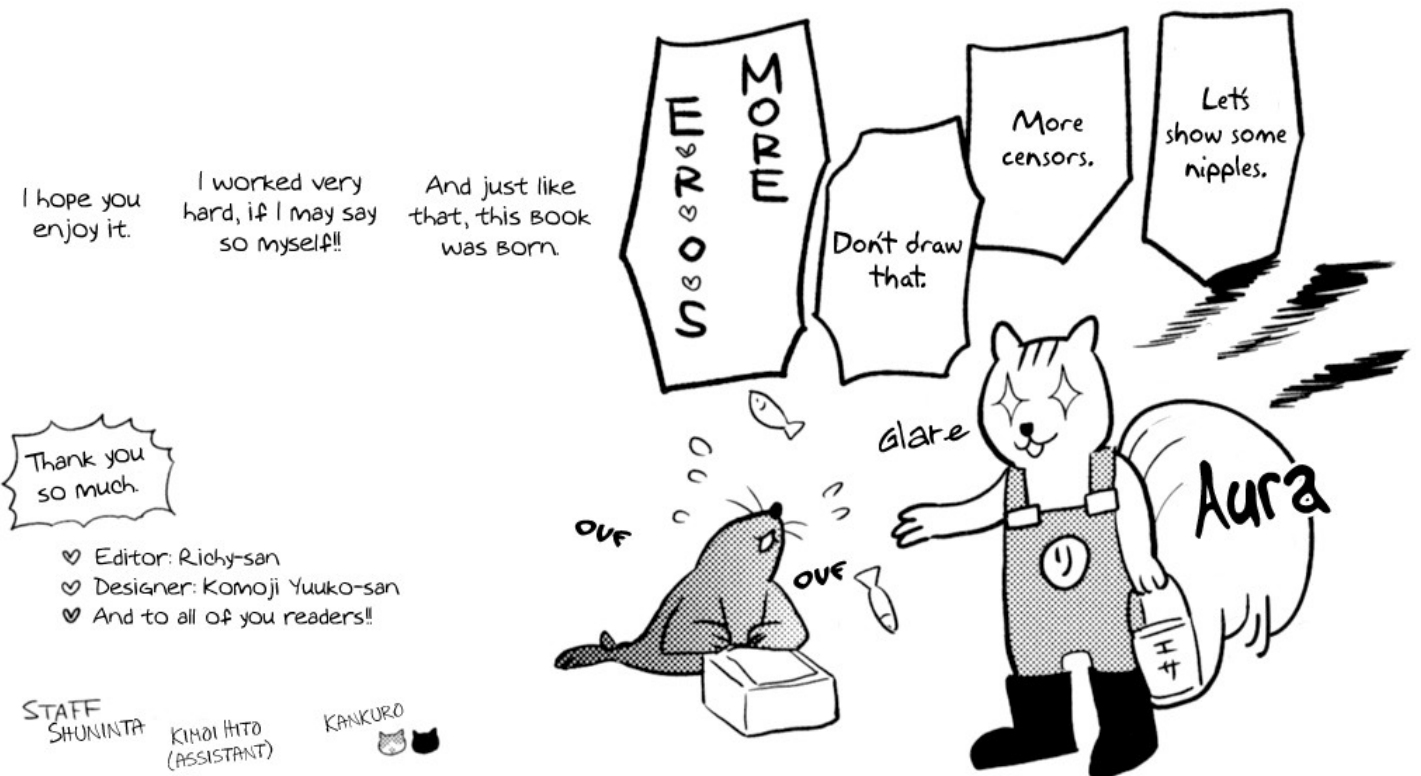
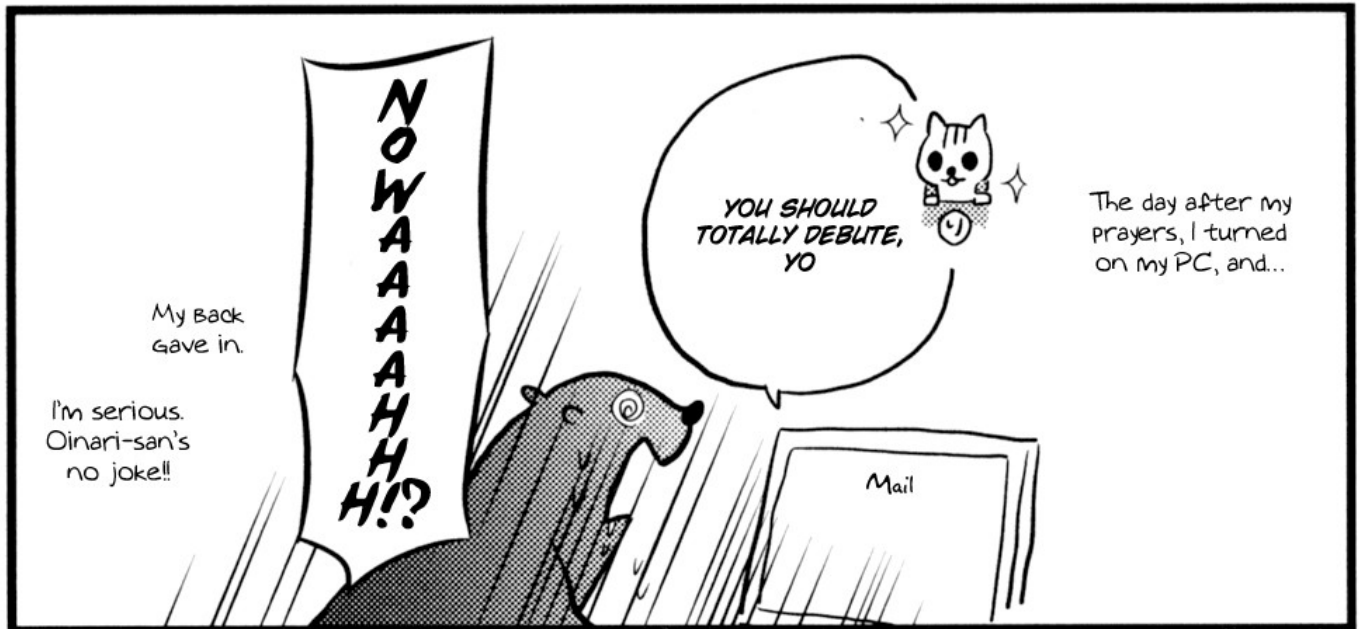
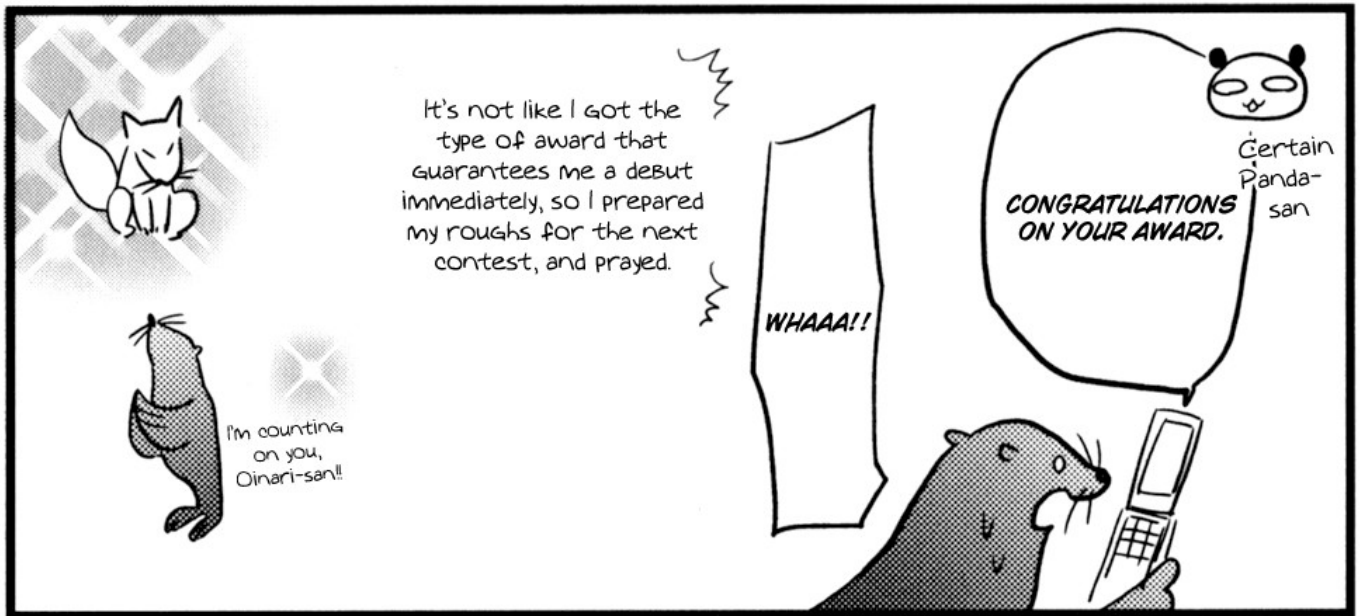

Yuri-Hime COMICS

## 漏けむりサンクチュアリ

---

2009年12月1日 初版発行

著者	天野しゆにんた
発行人	杉野庸介
発行所	株式会社一迅社 〒160-0022 東京都新宿区新宿2-5-10 成信ビル8F 電話 03-5312-7427(編集部) 03-5312-6150(営業部) <a href="http://www.ichijinsha.co.jp/">http://www.ichijinsha.co.jp/</a>
印刷・製本	図書印刷株式会社
装丁	こもちゆうこ
編集	中村成太郎

本書の一部または全部を無断で転載及び複製(コピー)することは、  
著作権法上での例外を除き、禁じられています。乱丁・落丁は当社販売課までお送りください。  
送料当社負担にてお取り替えいたします。定価はカバーに表示してあります。

IDコミックス ISBN978-4-7580-7064-5

©天野しゆにんた／一迅社 2009 Printed in Japan

★この作品はフィクションです。実在の人物・団体・事件などとはいっさい関係ありません。

Tranquil Spring and Payapaya Scans present...



Yukemuri Sanctuary - Chapter 07

Raws : Audio Erotica

Translator : Hitsuji-san

Proofreader : Babelglyph

Editor: Kite

Quality Checkers : Audio Erotica



**I  
NEED  
MORE  
YURI!**

ahn!  
more  
...

I  
need  
more!  
annn.

**TIRED OF  
SCHLICKING  
TO THE  
SAME OLD  
YURI?**

**DOES IT  
SEEM LIKE  
ALL THE  
SCANLATION  
GROUPS ARE  
SLOW AS  
FUCK?**

**CAN YOU:  
PROVIDE RAWS?  
TRANSLATE?  
EDIT?  
PROOFREAD?  
QUALITY CHECK?**

**IF SO  
JOIN A YURI  
SCANLATION  
GROUP TODAY  
AND GET A  
LESBIAN TO  
COME FOR U!**